



# fittingstor™

**Product code: FC3**

- » Secure cabinet designed for storing fittings and materials.
- » Comes with three removable shelves and 15 storage bins (code FCB).
- » Heavy-duty doors with anti-jemmy protection.



## Product features



2x 5-lever deadlock



Forklift skids



Suitable for site

## Product specifications

Weight	139kg
Colour	Black grey: RAL 7021
Suitable for	Site
Finished coating	Powder coated
Material & thickness	1.6mm and 2mm steel
Quantity of keys	3 keys
Suitable for vehicle mounting	No
How are castors fitted?	Quick-fix bolt on castor kit
Other sizes available	4 other sizes
Qty of shelves as standard	3

## Dimensions - External dimensions includes protrusions

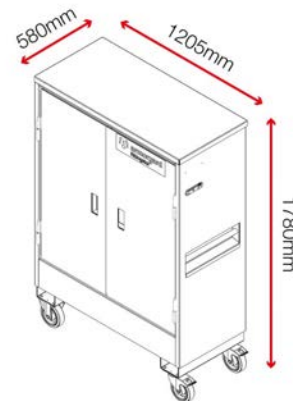

## Optional extras - Contact Armorgard to find out more



Fittings bins FCB



Shelf SHE-C3

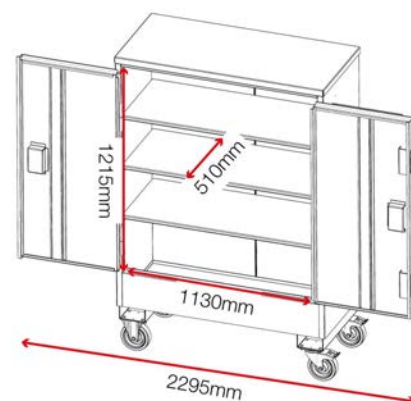

**Disclaimer: all dimensions and weights are approximate**