



fittingstor™

Product code: FC5

- » Secure cabinet designed for storing fittings and materials.
- » Bi-fold design for efficient use of space
- » Powder coated finish for maximum durability.



Watch the
FittingStor in
action

Product features



Standard 6" castors



Forklift skids



Built in handles



Padlock secured



Suitable for site

Specifications

Weight	160kg
Colour	Black grey: RAL 7021, Traffic red: RAL 3020
Suitable for	Site
Finished coating	Powder coated
Material & thickness	1.5mm and 2mm steel
Quantity of keys	N/A
Suitable for vehicle mounting	No
How are castors fitted?	Quick-fix bolt on castor kit
Other sizes available	4 other sizes
Qty of power sockets	6 welded shelves

Dimensions - External dimensions includes protrusions

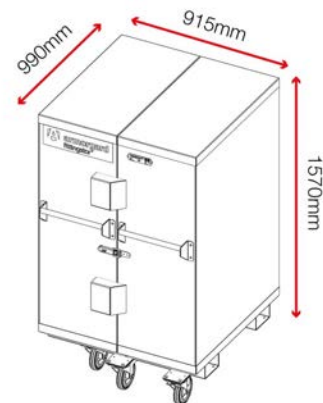

Optional extras - Contact Armorgard to find out more



Fittings bins FCB

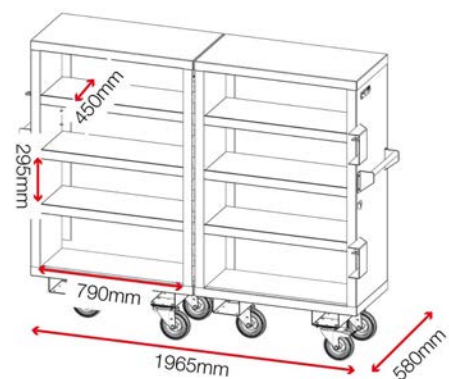

Disclaimer: all dimensions and weights are approximate