



# transbank™

**Product code: TRB3**

- » Fully welded unit, for storing and transporting fuels and chemicals.
- » Suitable for vehicle mounting in line with regulations.
- » Designed for storing 3 x 20 litre cans.



**Watch the  
TransBank in  
action**

## Product features



Padlock secured



COSHH compliant



Sump capacity



Fire resistant



No detachable  
parts



Safety signage



Suitable for vehicles

## Product specifications

Weight	24kg
Colour	Traffic red: RAL 3020
Suitable for	Transporting flammables & chemicals - 3 x 20L cans
Finished coating	Powder coated
Material & thickness	1.2mm steel
Quantity of keys	No
How are castors fitted?	Not applicable
Other sizes available	4 other sizes
Ventilation	Yes
Qty of shelves as standard	Not applicable

## Dimensions - External dimensions includes protrusions

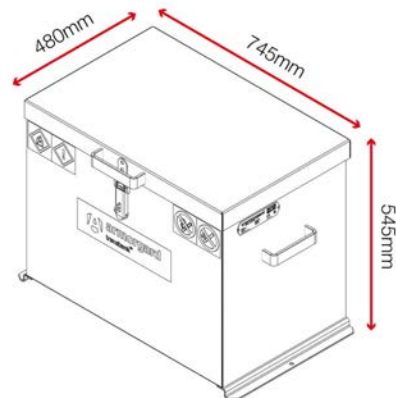

## Optional extras - Contact Armorgard to find out more



Padlock LOCK-P50

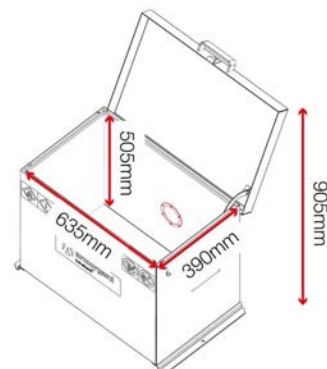

**Disclaimer: all dimensions and weights are approximate**