



Barcode: 5060452083223

Patent: GB2301393

Version: v100.9



# volthub™

## Safe Li-Ion battery charging

Product code: VH16-110

- » Designed to safely charge and store Li-Ion batteries.
- » Passive and active technology with battery backup.
- » Weatherproof, secure and mobile, VoltHub can go anywhere.



### Product features



Automatic fire suppression



Power supply 110V



32A IP67 power inlet



Suitable for site



Safety signage



Crane lifting eyes



Standard 200mm castors

### Product specifications

Weight	334kg
Colour	Black grey: RAL 7021, Traffic red: RAL 3020
Suitable for	Li-Ion battery charging
Finished coating	Powder coated
Material & thickness	1.5mm
Quantity of keys	2 keys
How are castors fitted?	Castor plates
Ventilation	Yes
Qty of shelves as standard	16 lockers
Qty of power sockets	32x 110V sockets

### Dimensions - External dimensions includes protrusions

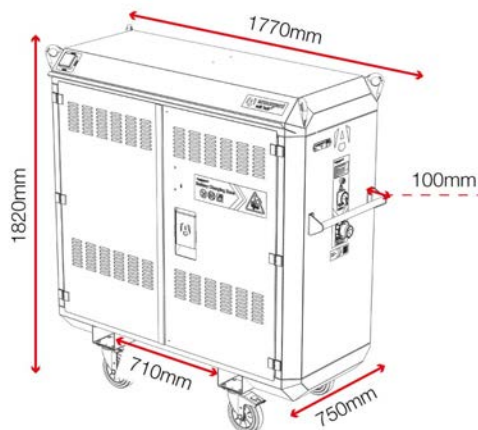

### Related products - Contact Armorgard to find out more



Power-Stor FR200-P



VoltHub VH16-240

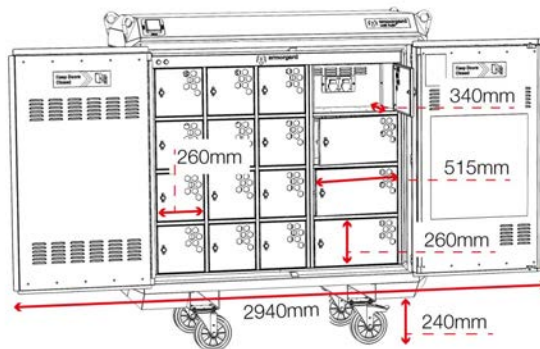

Disclaimer: all dimensions and weights are approximate