

Plan area motorcycle roller brake tester: top view

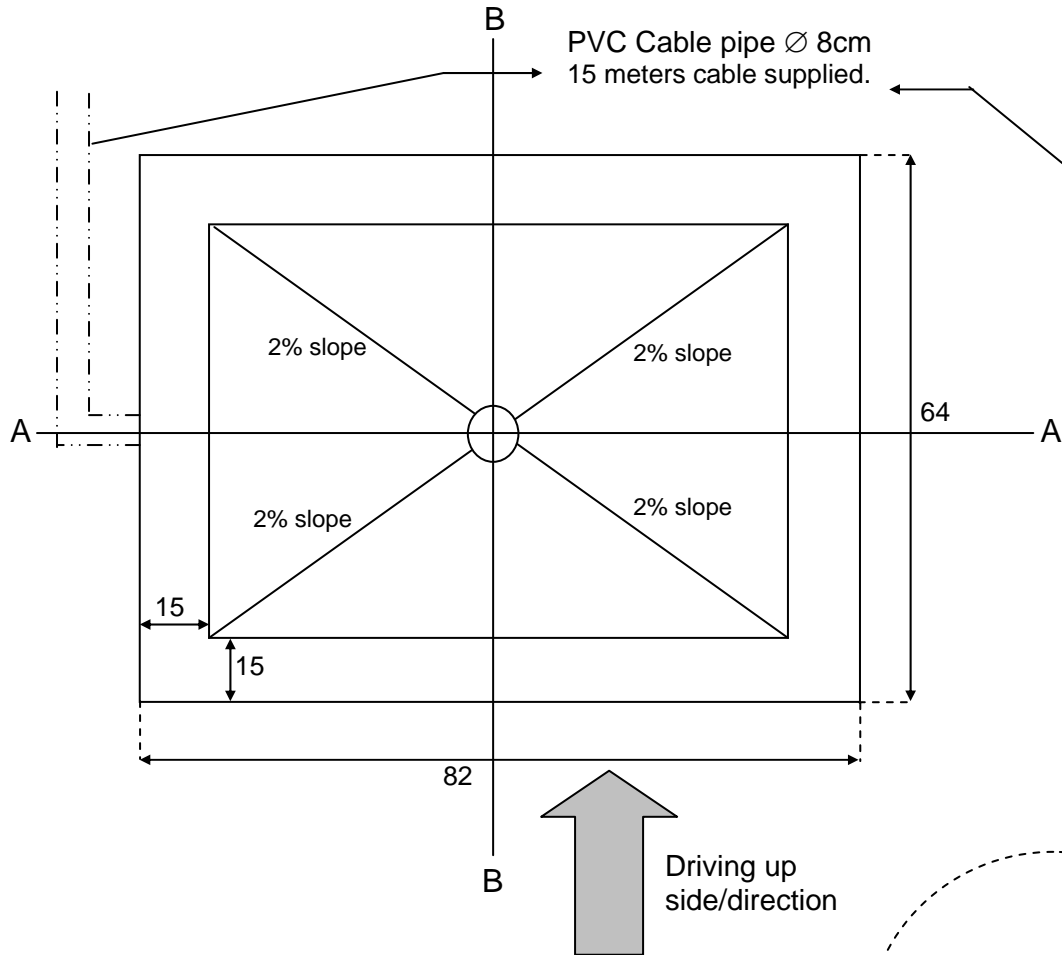

Section A-A: front view

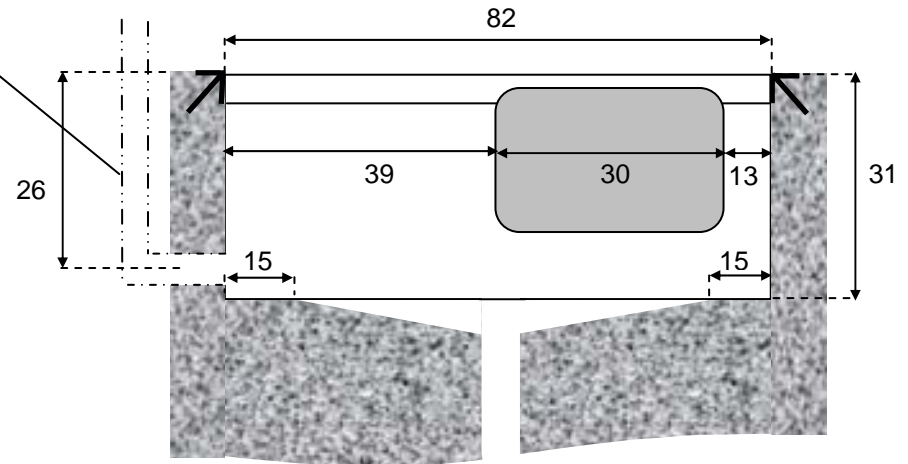

Section B-B: side view

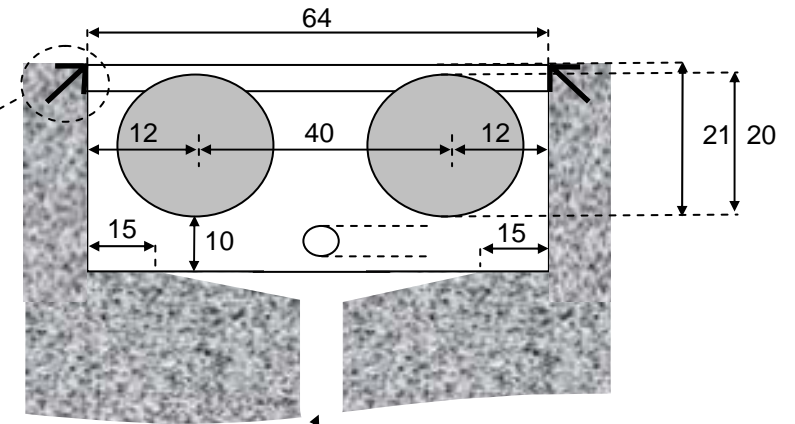

Water drainage with one-way valve.

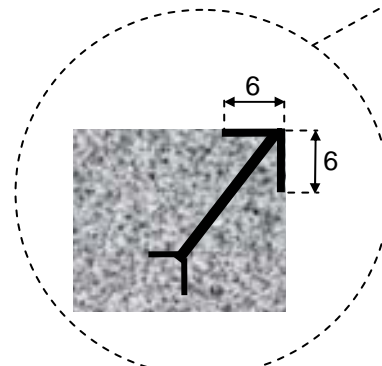

Detail 1

Floor plan R100(W) Motorcycle roller brake tester	
Doc. No.	BOS0037
Date	April 10, 2001
Dimensions	cm
Power	3 Ph. 400V / 50Hz / 16A
Overall net pit dimensions	82 x 64 x 31 cm
Overall net equipment dimensions	80 x 62 x 31 cm