

### Car & Van Braketesters

#### Product Codes D412 / D712

Boston's new D412 and D712 are the latest additions to our braketester range. Both models can be upgraded with a vehicle weighing system for motorcycle testing and DVSA approved Automated Test Lanes, and any of our emissions packages can easily be added to provide a combined braketester and emissions testing system.

4WD testing comes as standard, rollers carry a FIVE year guarantee, and remote 'over the internet' assistance is built in for immediate support direct from our service department.

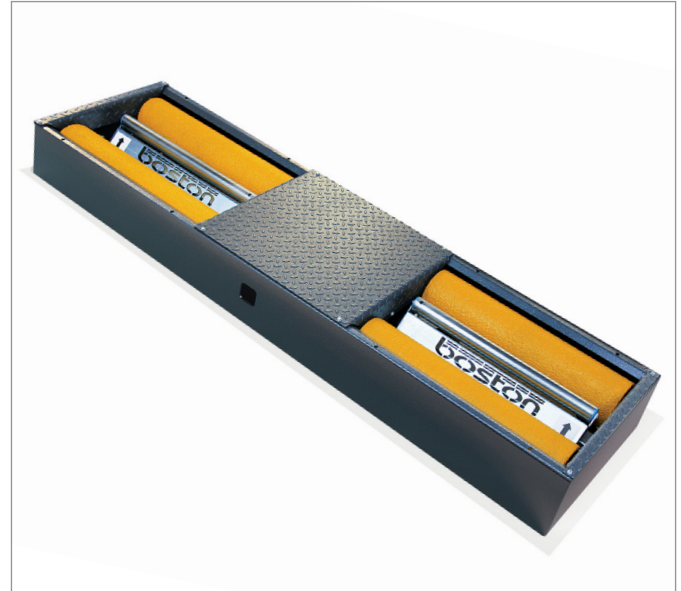

#### SW900 - Product Software

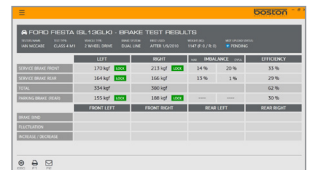
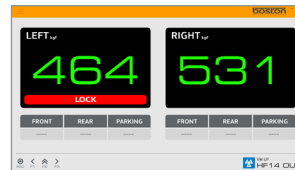
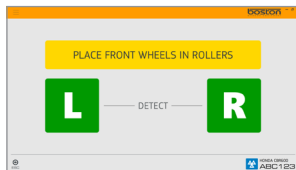

#### Product Features

- ✓ Roller beds galvanised and painted
- ✓ Installation cartridges galvanised and painted
- ✓ Single bed symmetrical chassis
- ✓ 5 year roller surface guarantee
- ✓ Very latest DVSA ATL software
- ✓ Emissions software included as standard
- ✓ Built-in remote assistance (internet required)
- ✓ Every official test saved automatically
- ✓ 4WD testing as standard
- ✓ High quality RFC-96 remote control (50m+ range)
- ✓ 27" flat panel LED display
- ✓ 50"+ secondary display (optional)
- ✓ Motorcycle testing compatible (optional)
- ✓ All software and electronics made in the UK
- ✓ OEM customisation available

## Car & Van Braketesters

### Technical Specifications

	D412 - MOT Class 1, 2, 3 & 4	D712 - MOT Class 5L & 7
Power (Full Load)	3ph - 400V / 50 Hz / 32A	3ph - 400V / 50 Hz / 32A
Motors	2 x 3.0 kW	2 x 4.0 kW
Electronics / Communication	USB Interface - PC Controlled	USB Interface - PC Controlled
Brake Testing Speed	2.9 km/h	2.9 km/h
Chassis Weight and Build	425 kg – Fully Galvanised and Painted	510 kg – Fully Galvanised and Painted
Max. Brake Force (per wheel)	900 kgf	1450 kgf
Max. Axle Load	3500 kg	4500 kg
Friction Roller Surface	0.9 $\mu$ dry / > 0.6 $\mu$ wet	0.9 $\mu$ dry / > 0.6 $\mu$ wet
Display Dimensions	LED Monitor, 27" standard (larger optional)	LED Monitor, 27" standard (larger optional)
Control System	GCP3 / GCP4 Control Station (Windows 11 + SW900 Software)	GCP3 / GCP4 Control Station (Windows 11 + SW900 Software)
Operator Control	Wireless Keyboard / RF Remote Control / (50m+ range)	Wireless Keyboard / RF Remote Control / (50m+ range)
Axle Weighing System	Optional (D412W)	Optional (D712W)

### Measurements (millimetres)

	D412	D712
Roller Width	700 mm	900 mm
Roller Centres	420 mm	420 mm
Roller Bed Chassis (L x W x H)	2340 x 660 x 300 mm	2730 x 660 x 320 mm

Car & Van Braketesters

Schematics D412

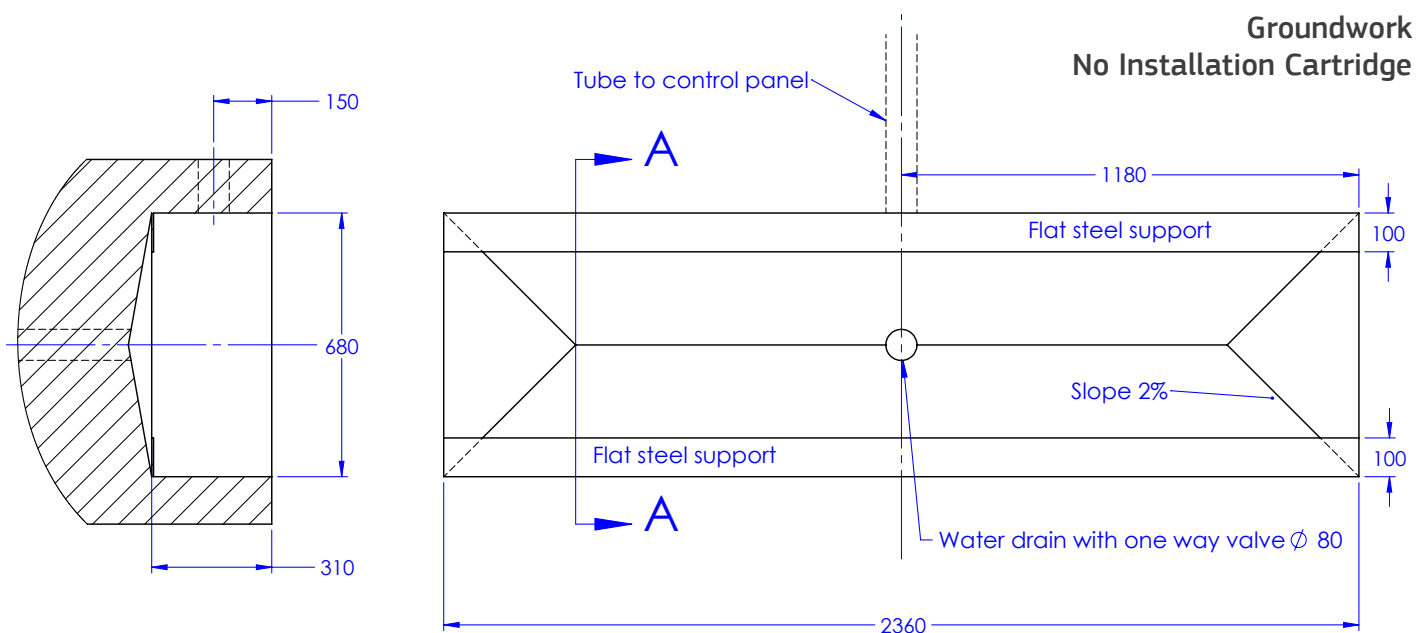
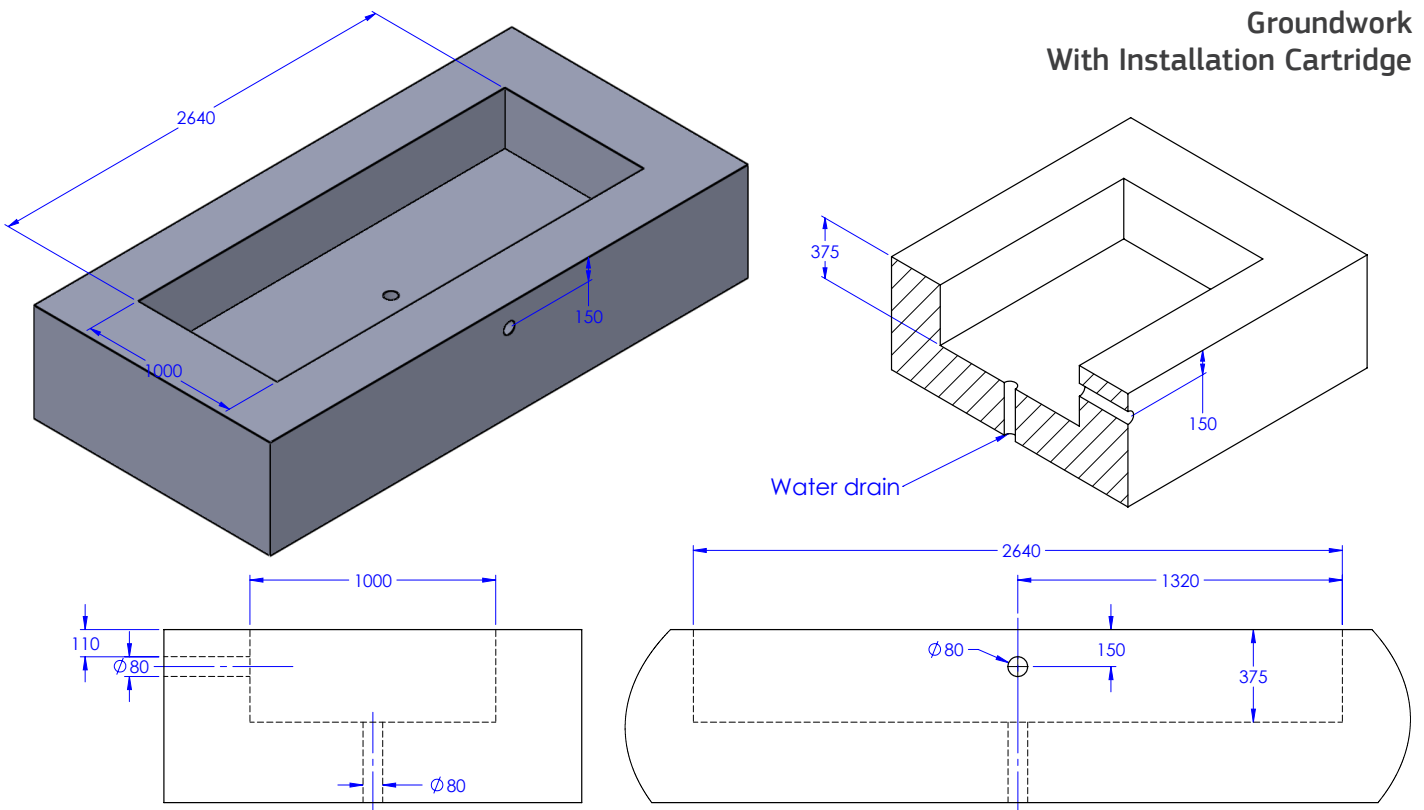

Boston makes every effort to ensure the accuracy of our product drawings and measurements. However, we reserve the right to correct any errors, inaccuracies or omissions and to change or update information at any time without prior notice.

Car & Van Braketesters

Schematics D712

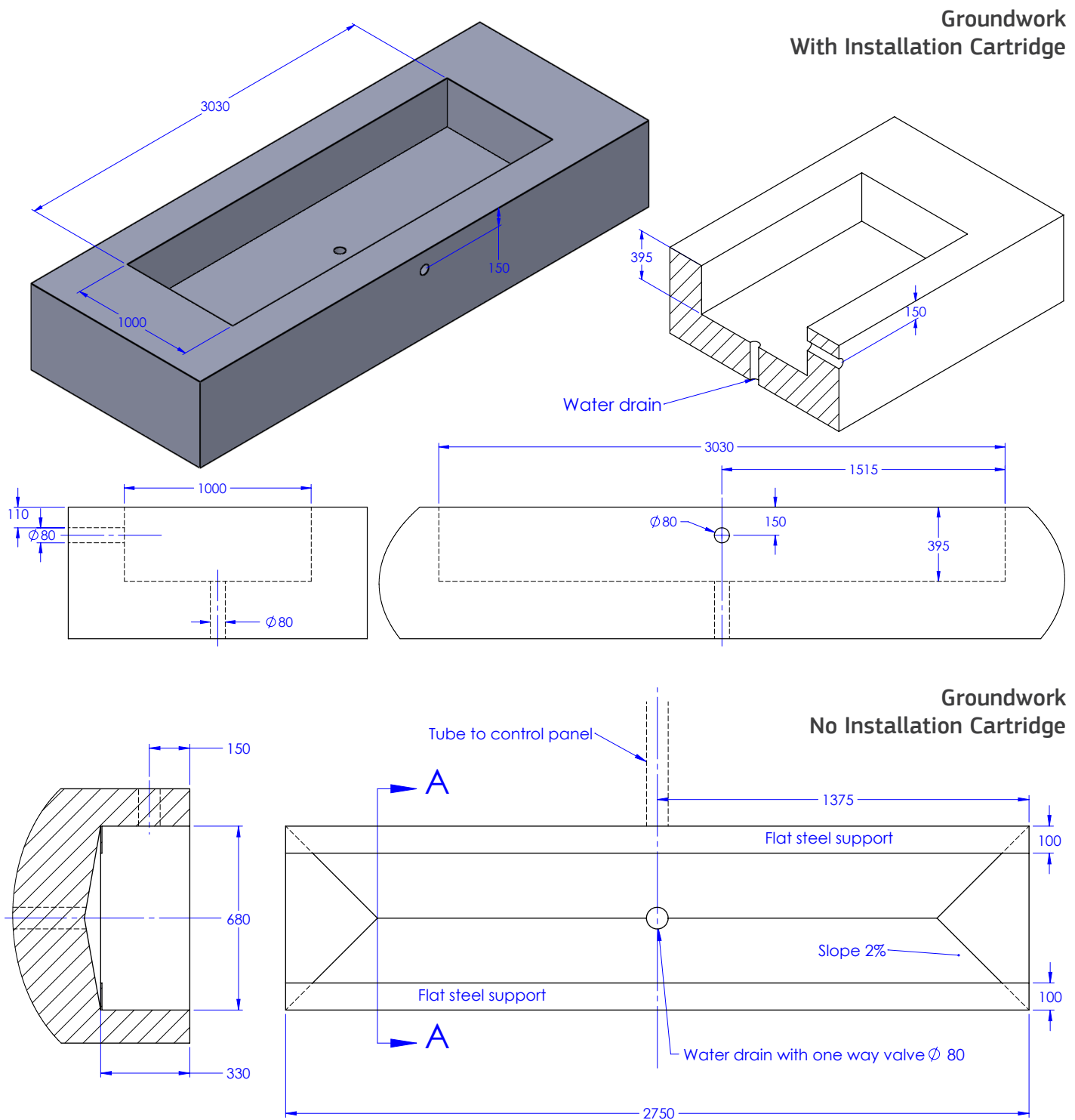

Boston makes every effort to ensure the accuracy of our product drawings and measurements. However, we reserve the right to correct any errors, inaccuracies or omissions and to change or update information at any time without prior notice.