



ERGONOMIC AND EFFECTIVE WHEEL  
TROLLEY FOR YOUR WORKSHOP



**AC Hydraulic**<sup>A/S</sup>  
NO COMPROMISE

# UNIQUE WHEEL HANDLING

When it comes to aiding the removal and transportation of large wheels the WT1500NT is in a league of its own. It offers better ergonomics and improvements on both safety and maneuverability compared to other models in the market.

## TRULY A ONE-MAN OPERATION

A waist high hydraulic pump handle moves the jaws in and out to accept the different size wheels. The handle is

also used to raise or lower the wheel. A ratchet strap secures the unbolted wheel in place to give maximum safety, this also allows good access to the wheel nuts and more efficient working space.

A unique feature of the WT1500NT is the ability to rotate the wheel to align the studs perfectly when re-fitting the wheel. This is done simply by rotating a handle on the control post.

With the aid of the WT1500NT wheel handling truly becomes a one-man operation and it is a must for any workshop moving large heavy wheels with safety and efficiency in mind.



“Thanks to the WT1500NT handling large heavy wheels is now truly a one-man operation”

*Peder Mortensen,  
Sørensen & Lynggaard*









7140

AFS

X-FLUX

CASE IH

AXIAL-FLOW



CAPACITY  
**1500**KG



# FEATURES

## 1 IMPROVED MANEUVERABILITY

Very manoeuvrable and easy to use due to optimum handle position and industrial strength castor wheels.

## 2 HANDLE

The handle for the hydraulic pump allows you to expand or retract the jaws without using any strength.

## 3 STORAGE OF RATCHET STRAP

Small storage space for ratchet strap. The ratchet strap secures the unbolted wheel in place to give maximum safety.

## 4 PUMP SWITCH

Simple switch allows the pump function to change jaw direction for retracting or expanding of jaws.

## 5 UNIQUE RE-FITTING

Rotates the wheel both ways, making the job of aligning wheel studs to the hub a simple and precise operation.

## 6 GOOD ACCESS

Easy access to the wheel nuts, an improvement on models that use a post and bracket to go over the wheels.







*Rotate the wheel to align the studs perfectly when re-fitting the wheel*

*Optimum packaging for ease of delivery and reduction of freight cost*

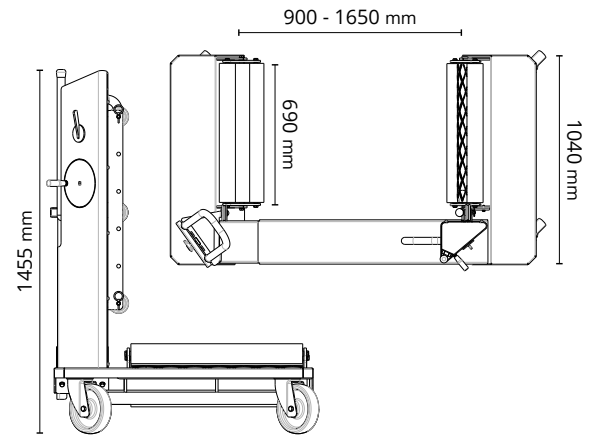

# NO COMPROMISE

Just as our products offer high performance and quality, so does our warranty. The immense amount of workmanship, testing, and precision fabrication that each of our products receives enables us to maintain our high quality.

## THE WORLD'S LONGEST WARRANTY

Since January 1st 2017 all our products are covered by a 10 year warranty on frame, chassis, and steel structures as well as a 3 year warranty on the hydraulic system (pump and cylinder).

Offering you the world's longest warranty is our way of proving that our quality is without compromise.



Simply because we trust our quality  
We have made no changes in terms  
or claim handling. We simply trust  
our quality enough to extend the  
warranty to 10 year / 3 year

## AC Hydraulic A/S

Fanøvej 6 • DK-8800 Viborg • Tel. +45 8727 6400 • Fax +45 8662 2988  
E-mail: ac@ac-hydraulic.dk • www.ac-hydraulic.com

*LEARN MORE:*  
**[WWW.AC-HYDRAULIC.COM](http://WWW.AC-HYDRAULIC.COM)**



**AC Hydraulic** <sup>A/S</sup>  
NO COMPROMISE