

**datavideo**

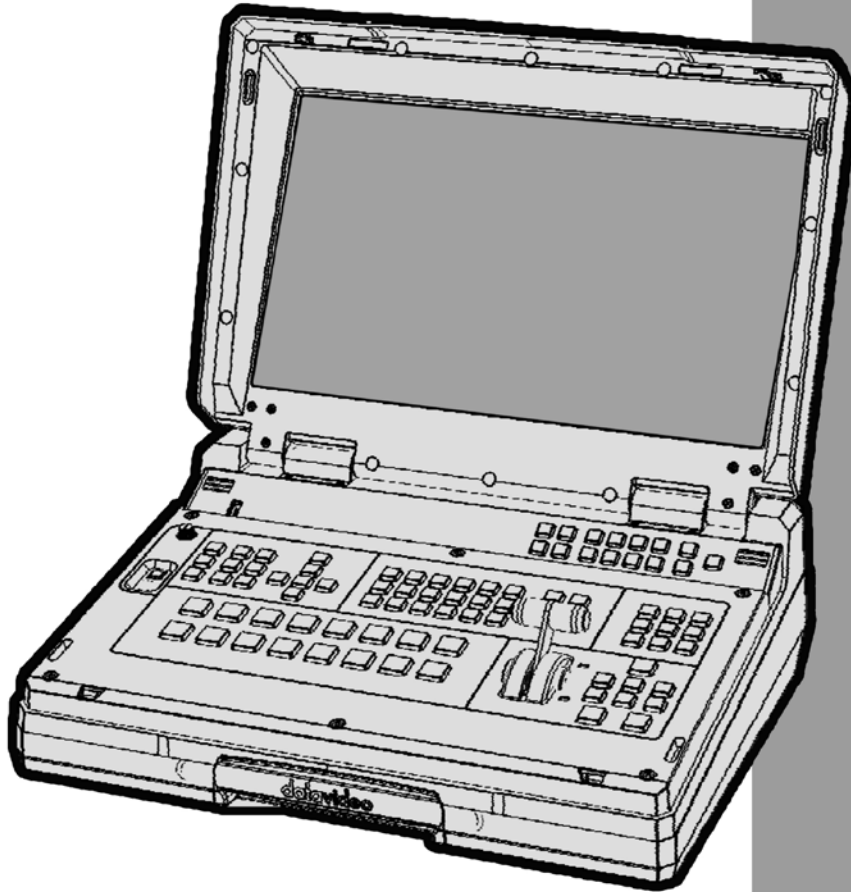

**HD 6-CHANNEL  
PORTABLE VIDEO STUDIO  
HS-1200  
Instruction Manual**

[www.datavideo.com](http://www.datavideo.com)

# Contents

<b>WARNINGS AND PRECAUTIONS .....</b>	<b>4</b>
<b>WARRANTY .....</b>	<b>5</b>
STANDARD WARRANTY .....	5
TWO YEAR WARRANTY .....	5
<b>DISPOSAL .....</b>	<b>5</b>
<b>1. INTRODUCTION.....</b>	<b>6</b>
1.1 FEATURES.....	6
<b>2. REAR PANEL .....</b>	<b>7</b>
2.1 REAR PANEL CONNECTIONS .....	7
<b>3. CONTROL PANEL .....</b>	<b>9</b>
3.1 SWITCHER CONTROL PANEL .....	9
3.2 MONITOR CONTROL PANEL .....	14
<b>4. SWITCHER OSD MENU OVERVIEW .....</b>	<b>16</b>
<b>5. SWITCHER OSD MENU FUNCTIONS .....</b>	<b>22</b>
5.1 START.....	22
<i>Transition</i> .....	22
<i>Wipe Effects</i> .....	22
<i>Border</i> .....	23
<i>Position</i> .....	23
<i>Matte</i> .....	23
5.2 KEYER .....	23
<i>Keyer Control</i> .....	23
<i>Key Source</i> .....	24
<i>Fill Source</i> .....	24
<i>Mask</i> .....	24
5.3 CHROMA .....	24
<i>Keyer</i> .....	24
<i>CK Setup</i> .....	25
<i>Mask</i> .....	25
5.4 P-IN-P .....	25
<i>Position</i> .....	26
<i>Border</i> .....	26
<i>Border Width</i> .....	26
<i>Crop</i> .....	26
5.5 P-IN-P LITE .....	26
<i>Position</i> .....	27
<i>Border</i> .....	27
<i>Border Width</i> .....	27

<i>Crop</i> .....	27
5.6 INPUTS.....	27
<i>Input 1-4</i> .....	28
<i>Freeze</i> .....	28
<i>Crosspoint</i> .....	28
5.7 OUTPUTS.....	28
<i>Outputs</i> .....	29
<i>Audio</i> .....	29
<i>GPI Out</i> .....	29
<i>Multiviewer</i> .....	29
5.8 STILLS .....	30
<i>Load Still</i> .....	30
<i>Save Still</i> .....	30
<i>Freeze</i> .....	31
5.9 USER MEMS.....	31
<i>Load Memory</i> .....	31
<i>Save Memory</i> .....	31
5.10 SETUP .....	31
<i>Menu Preference</i> .....	32
<i>Standard</i> .....	32
<i>Menu Mode</i> .....	32
<i>Auto Save</i> .....	32
<i>Factory Default</i> .....	32
<i>Reset Names</i> .....	32
<i>Language</i> .....	33
<i>Software</i> .....	33
<b>6. MONITOR OSD MENU OPTIONS.....</b>	<b>34</b>
<b>7. FIRMWARE UPDATE PROCEDURE .....</b>	<b>35</b>
<b>8. GPI CONNECTION .....</b>	<b>36</b>
<b>9. TALLY OUTPUTS.....</b>	<b>36</b>
<b>10. DIMENSIONS .....</b>	<b>37</b>
<b>11. SPECIFICATIONS .....</b>	<b>38</b>
<b>SERVICE AND SUPPORT.....</b>	<b>40</b>

### **Disclaimer of Product and Services**

The information offered in this instruction manual is intended as a guide only. At all times, Datavideo Technologies will try to give correct, complete and suitable information. However, Datavideo Technologies cannot exclude that some information in this manual, from time to time, may not be correct or may be incomplete. This manual may contain typing errors, omissions or incorrect information. Datavideo Technologies always recommend that you double check the information in this document for accuracy before making any purchase decision or using the product. Datavideo Technologies is not responsible for any omissions or errors, or for any subsequent loss or damage caused by using the information contained within this manual. Further advice on the content of this manual or on the product can be obtained by contacting your local Datavideo Office or dealer.

# Warnings and Precautions



1. Read all of these warnings and save them for later reference.
2. Follow all warnings and instructions marked on this unit.
3. Unplug this unit from the wall outlet before cleaning. Do not use liquid or aerosol cleaners. Use a damp cloth for cleaning.
4. Do not use this unit in or near water.
5. Do not place this unit on an unstable cart, stand, or table. The unit may fall, causing serious damage.
6. Slots and openings on the cabinet top, back, and bottom are provided for ventilation. To ensure safe and reliable operation of this unit, and to protect it from overheating, do not block or cover these openings. Do not place this unit on a bed, sofa, rug, or similar surface, as the ventilation openings on the bottom of the cabinet will be blocked. This unit should never be placed near or over a heat register or radiator. This unit should not be placed in a built-in installation unless proper ventilation is provided.
7. This product should only be operated from the type of power source indicated on the marking label of the AC adapter. If you are not sure of the type of power available, consult your Datavideo dealer or your local power company.
8. Do not allow anything to rest on the power cord. Do not locate this unit where the power cord will be walked on, rolled over, or otherwise stressed.
9. If an extension cord must be used with this unit, make sure that the total of the ampere ratings on the products plugged into the extension cord do not exceed the extension cord's rating.
10. Make sure that the total amperes of all the units that are plugged into a single wall outlet do not exceed 15 amperes.
11. Never push objects of any kind into this unit through the cabinet ventilation slots, as they may touch dangerous voltage points or short out parts that could result in risk of fire or electric shock. Never spill liquid of any kind onto or into this unit.
12. Except as specifically explained elsewhere in this manual, do not attempt to service this product yourself. Opening or removing covers that are marked "Do Not Remove" may expose you to dangerous voltage points or other risks, and will void your warranty. Refer all service issues to qualified service personnel.
13. Unplug this product from the wall outlet and refer to qualified service personnel under the following conditions:
  - a. When the power cord is damaged or frayed;
  - b. When liquid has spilled into the unit;
  - c. When the product has been exposed to rain or water;
  - d. When the product does not operate normally under normal operating conditions. Adjust only those controls that are covered by the operating instructions in this manual; improper adjustment of other controls may result in damage to the unit and may often require extensive work by a qualified technician to restore the unit to normal operation;
  - e. When the product has been dropped or the cabinet has been damaged;
  - f. When the product exhibits a distinct change in performance, indicating a need for service.

# Warranty

## Standard Warranty

- Datavideo equipment is guaranteed against any manufacturing defects for one year from the date of purchase.
- The original purchase invoice or other documentary evidence should be supplied at the time of any request for repair under warranty.
- Damage caused by accident, misuse, unauthorized repairs, sand, grit or water is not covered by this warranty.
- All mail or transportation costs including insurance are at the expense of the owner.
- All other claims of any nature are not covered.
- Cables & batteries are not covered under warranty.
- Warranty only valid within the country or region of purchase.
- Your statutory rights are not affected.

## Two Year Warranty

- All Datavideo products purchased after 01-Oct.-2008 qualify for a free one year extension to the standard Warranty, providing the product is registered with Datavideo within 30 days of purchase. For information on how to register please visit [www.datavideo-tek.com](http://www.datavideo-tek.com) or contact your local Datavideo office or authorized Distributors
- Certain parts with limited lifetime expectancy such as LCD Panels, DVD Drives, Hard Drives are only covered for the first 10,000 hours, or 1 year (whichever comes first).



Any second year warranty claims must be made to your local Datavideo office or one of its authorized Distributors before the extended warranty expires.

## Disposal

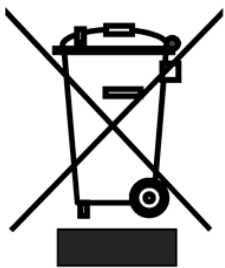

### For EU Customers only - WEEE Marking

This symbol on the product indicates that it will not be treated as household waste. It must be handed over to the applicable take back scheme for the recycling of electrical and electronic equipment. For more detailed information about the recycling of this product, please contact your local Datavideo office.

# 1. Introduction

The HS-1200 is a cost effective 6 channel broadcast-quality hand-carry mobile switcher, it is designed for live events and TV programs that need to mix a variety of video and audio sources. The HS-1200 is a lightweight, portable and powerful featured mobile studio solution.

Friendly and advanced features include a 17.3-inch video monitor, which displays the multi-view. The Multi-view includes all the input sources, as well as preview and program.

The HS-1200 is low power consumption and it is ideal for TV and video professionals working in outside broadcast or on-the-go video studios, such as theatres or conference centers. The HS-1200 is also a great value solution for the worship, education and AV market.

## 1.1 Features

- 6 video inputs ( SDI x 4 + HDMI x 2)
  - Frame Sync on each input
- 2 Video Output : ( SDI x 1 + HDMI x 1)
- 4 x XLR Analogue Audio Inputs
- Flexible Mix/Effects Processor with
  - 2 Upstream Keyers, supporting Chroma Key & Linear/Luma Key
  - 2 DSK, supporting Linear & Luma Key Modes
  - 1 PIP (assignable to any of the 4 keyers)
  - Wipe Generator
    - 32 Wipe Patterns, including Circle & Heart Borders & Softness Control
  - Wipe, Mix & Cut Transitions
  - Full M/E Preview function
- Any Input (1-6) can be used as a Frame store (Stills Store)
- Assignable Outputs
  - Each SDI output can be switched in the Menu as:
    - PROGRAM (w/ DSK)
    - Clean PROGRAM (w/o DSK)
    - Clean PREVIEW (w/o DSK)
    - MULTISCREEN
    - Input 1~6
- XPT (Cross Point Assignment)
- Tally Output
- GPI Output
- One 17.3-inch with a resolution of 1600x900 dots
- Easy to use On-screen Menu System for quick setting of parameters

## 2. Rear Panel

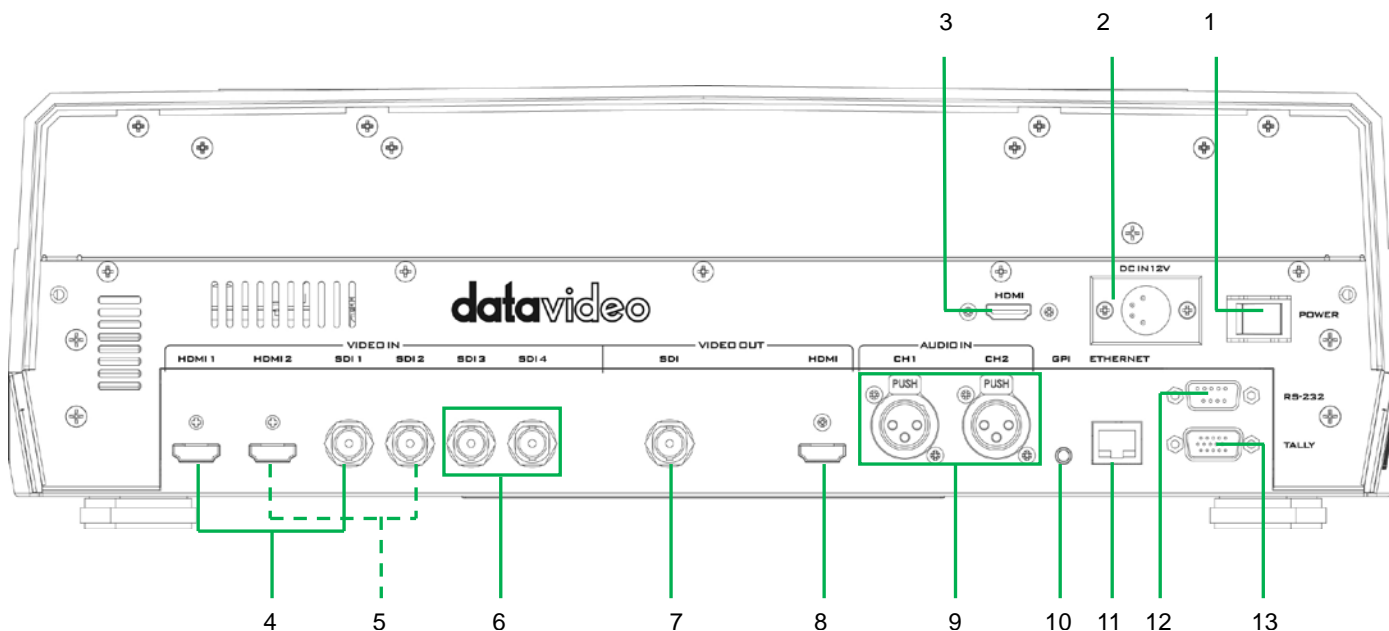

1	Power Switch	8	HDMI Video Output
2	4 PIN XLR Power Input Connector	9	3 PIN XLR Audio Inputs 1 - 2
3	Multi View Output - HDMI	10	GPI Output Connector
4	Input 1 – HD-SDI / HDMI	11	Ethernet Port
5	Input 2 – HD-SDI / HDMI	12	RS-232 Connector
6	HD-SDI Video Input 3 - 4	13	Tally Connector
7	HD-SDI Video Output		

### 2.1 Rear Panel Connections

#### ETHERNET

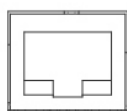

#### Ethernet Port

Remote control interface

#### RS-232

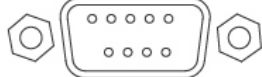

#### RS-232 Remote

Remote control interface

#### TALLY

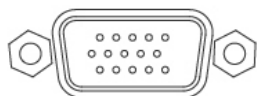

#### Tally

Sends **Red**, and **Green** tally signals to each channel. **Red** indicates On-Air, and **Green** indicates next camera source.

#### GPI



#### GPI

The GPI socket can be used for simple external control.

**Note: Please configure GPI settings in the Switcher Menu.**

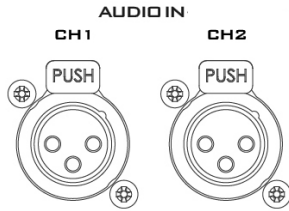

## AUDIO Inputs

Supports two XLR Balanced Audio Input channels.

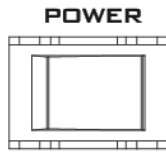

## POWER SWITCH

Switches the power On / Off.



## HDMI Multi-View Outputs

HS-1200 is capable of achieving multi-view monitoring by connecting multi-view monitor to the HDMI port. The HDMI output can be used for monitoring video and audio in a number of different configurations.

The HDMI connectors are located on the rear panel.

**Note:** HDMI multi-view output format is 1080i.

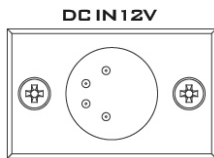

## DC Input

Connect the supplied 12V 5A PSU to this 4 PIN XLR socket.



## SDI Video Output

The BNC output connector is a user defined SDI output.

**Note:** Please set the OUTPUT SOURCE in the Switcher Menu.



## HDMI Video Output

The HDMI output connector is a user defined HDMI output.

**Note:** Please set the OUTPUT SOURCE in the Switcher Menu.



## Video Input Modules

The HS-1200 is equipped with six video input channels.

Video Input set is comprised of four SDI connectors and two HDMI ports. The first two channels (#1 and #2) can be alternated between SDI and HDMI interfaces, i.e. the user is allowed to use CH1 and CH2 for either an SDI source or an HDMI source.

**Note:** Please set the input source in the Switcher Menu.





# 3. Control Panel

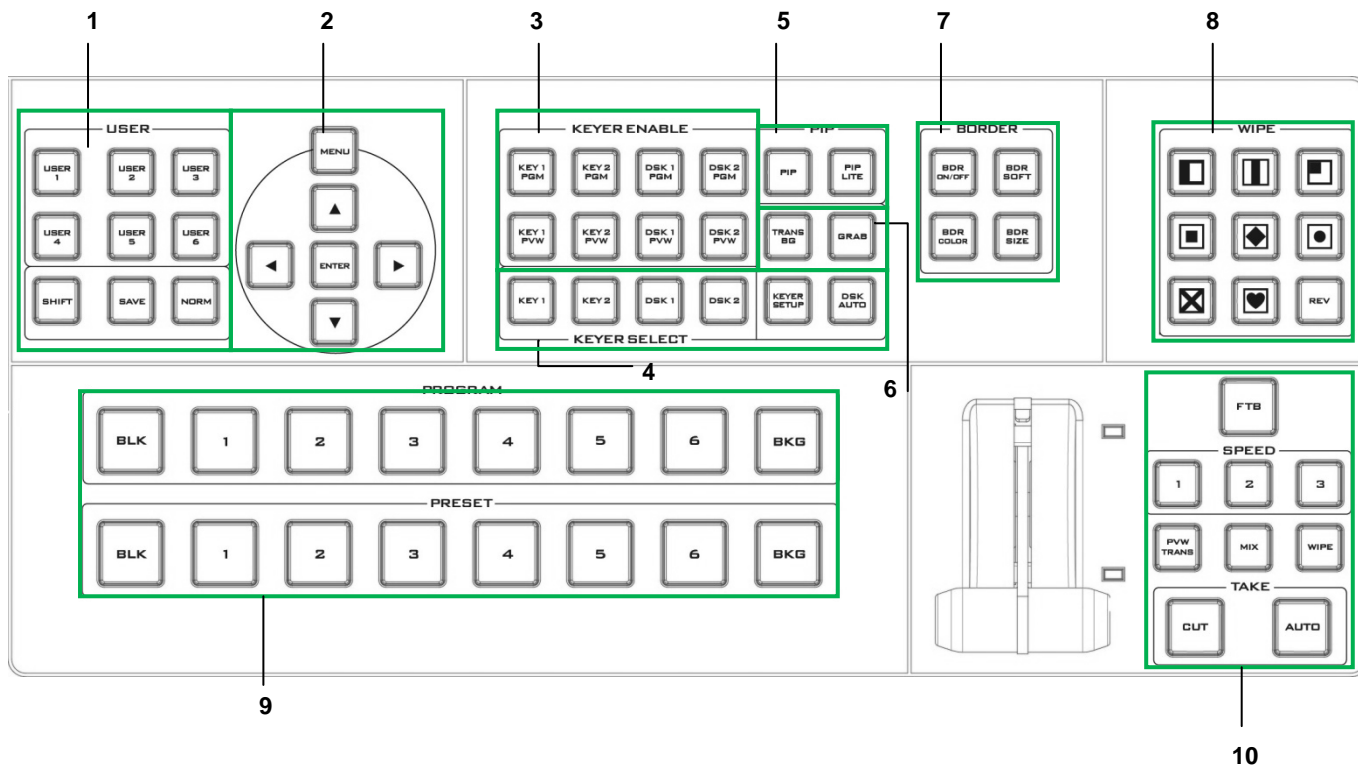





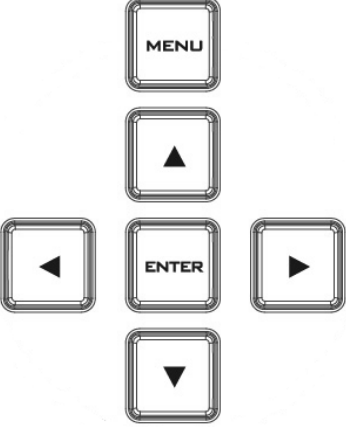

## 3.1 Switcher Control Panel

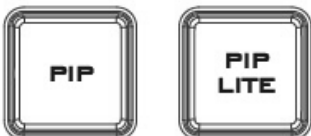

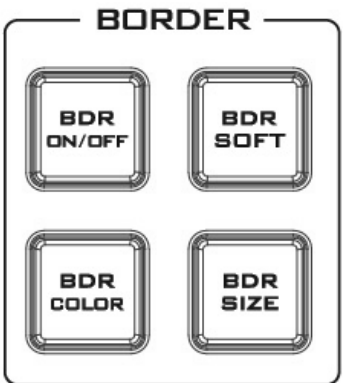
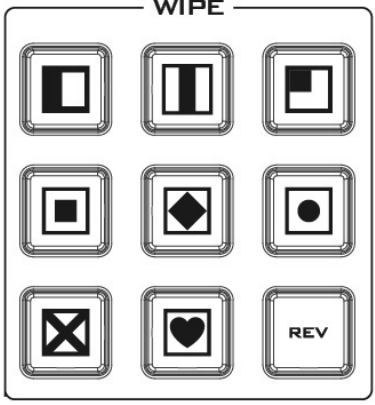
1	User Memory & Function Keys	6	Background Transition & GRAB
2	Menu Control	7	Wipe Border Setting
3	Keyer Selection	8	Wipe Transition Selection
4	Keyer Source	9	Program & Preview source rows
5	PIP Effect	10	Transition Effect

1. User Memory and Function Keys		<p><b>User Memory</b> User Memory buttons 1-6 allow the user to recall and load previously saved switcher settings.</p> <p><b>SHIFT</b> There are 12 user memory locations. Under normal circumstances, Buttons USER 1 to 6 represent user memory locations 1 to 6. To load settings saved in locations 7 to 12 to buttons USER 1-6, simply press the <b>SHIFT</b> button.</p> <p><b>SAVE: User Memory Save</b> The <b>SAVE</b> button saves the current switcher settings. To save, keep holding down this button and then select the User Memory number by pressing the corresponding User Memory button.</p> <p><b>Normalise Button</b> The <b>NORM</b> button resets the currently opened menu item to the default values.</p>
----------------------------------	--	--

2. Menu Control		<p><b>Menu Control</b></p> <p>Press the <b>MENU</b> button in the HS-1200 function section to enter the System Configuration Menu. Press the <b>UP</b>, <b>DOWN</b>, <b>LEFT</b>, and <b>RIGHT</b> arrow buttons to browse the menu options and change values. Use the <b>ENTER</b> button to save and confirm any setting that has been changed. To Exit, simply press the <b>MENU</b> button again.</p>
3. Keyer Selection		<p><b>Key 1 PGM</b> enables key 1 on the Multi view and PGM output</p> <p><b>Key 2 PGM</b> enables key 2 on the Multi view and PGM output</p> <p><b>DSK 1 PGM</b> enables DSK 1 on the Multi view and PGM output</p> <p><b>DSK 2 PGM</b> enables DSK 2 on the Multi view and PGM output</p> <p><b>Key 1 PVW</b> enables key 1 on the Multi view and PVW output</p> <p><b>Key 2 PVW</b> enables key 2 on the Multi view and PVW output</p> <p><b>DSK 1 PVW</b> enable DSK 1 on the Multi view and PVW output</p> <p><b>DSK 2 PVW</b> enable DSK 2 on the Multi view and PVW output</p>
4. Keyer Source		<p><b>Selection of Keyer Source from Program / Preset Row</b></p> <p>Keep holding down one of these buttons to enter key select mode and fill select mode. Select key source from the Program row and fill source from the Preset row.</p> <p>The selected source button will flash.</p> <p><b>KEYER SETUP</b></p> <p>Press this button to open Keyer configuration menu on the Multi view output, and the opened configuration menu corresponds to the selected keyer (Key 1/Key 2/DSK 1/DSK 2).</p> <p><b>DSK AUTO</b></p> <p>Auto DSK transition function either transitions “DSK 1 or DSK 2 individually” or transitions “DSK 1 and DSK 2 simultaneously”</p>

5. PIP Effect		<p><b>PIP</b> enables the PIP key mode</p> <p><b>PIP LITE</b> enables the PIP LITE key mode</p>
6. Background Transition & GRAB		<p><b>TRANS BG</b> enables Background Transition between Program / Preset</p> <p><b>GRAB</b> grabs the current Program video image</p>
7. Wipe Border Setting		<p><b>BDR ON/OFF</b> turns the WIPE border function ON/OFF</p> <p><b>BDR SOFT</b> configures the WIPE border softness</p> <p><b>BDR COLOR</b> selects the WIPE border color</p> <p><b>BDR SIZE</b> adjusts the WIPE border thickness</p>
8. Wipe Transition Selection		<p><b>WIPE Transition Selection</b></p> <p>The HS-1200 has 8 user defined wipe buttons that allow the user to select WIPE transition effect directly from the control panel. The REV button reverses the direction of the selected WIPE.</p> <p>All wipes can have an optional colour border applied. The wipe border width and colour are chosen within the menu system.</p> <p>Transitions can be performed manually using the T-Bar or automatically by using the SPEED and AUTO TAKE buttons.</p>
	 Vertical Wipe Left to Right  Upper Left corner Wipe to Lower Right corner  Diamond Wipe from Centre to outside edges	 Vertical Wipes from Centre to Left and Right sides  Box Wipe from Centre to outside edges  Circle Wipe from Centre to outside edges



Cross Wipe from Centre to outside edges



Heart Wipe from Centre to outside edges

9. Program & Preview Source Row

The Program row of buttons is the active channel, this is the live output. The active channel will appear as the Program Output. You can switch or CUT from one video source to another directly on the Program row. You will see the multi view Program output change as you press different keys along this top row of buttons.

The Preset row is the cued channel; this channel will appear in the Preview window. The Preset row selection decides which input will be transitioned next when using any of the transition controls.

Buttons 1, 2, 3, 4, 5 and 6 are video source buttons.

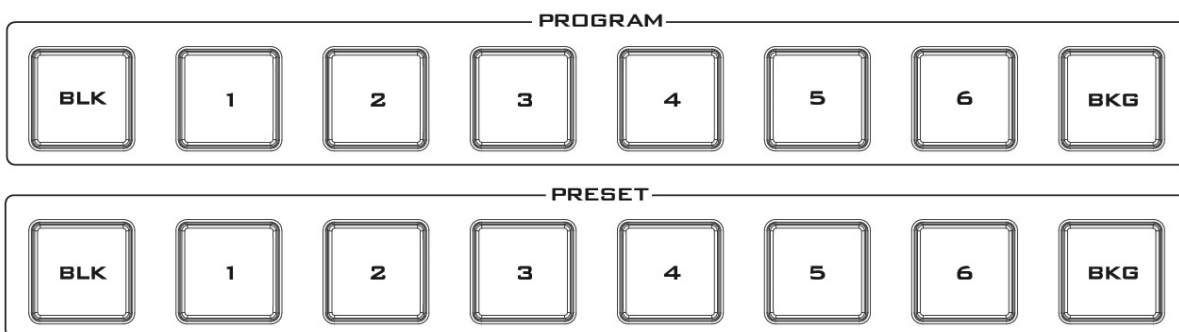

**BLK**

Black background – the black background, for use on the Program and Preset row.



**BG**

Background button – assigns a background colour or colour bars for use on the Program and Preset row.

10. Transition Effect



**FTB**

Fade To Black, this button fades the current video program source to black. When pressed again it acts in reverse from complete black to the currently selected program video source.

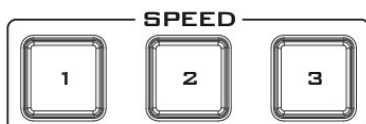

**SPEED**

There are three speed buttons which can be defined by the user. By pressing a speed button the user is choosing the rate of transition or time taken when using the AUTO TAKE button.

**Transition Speed (1, 2 and 3):**

Button 1= 12 frame duration, 2= 25 and 3= 50 at 1080i50

Button 1= 15 frame duration, 2= 30 and 3= 60 at 1080i60

**PVW TRANS**

Transition shown on PVW only

**MIX**

This button enables MIX transition effect.

**WIPE**

This button enables WIPE transition effect. The WIPE button must be selected when a wipe effect transition between the selected Program and Preset sources is required. This WIPE effect is produced by moving the T-Bar manually or pressing the AUTO TRANS button.

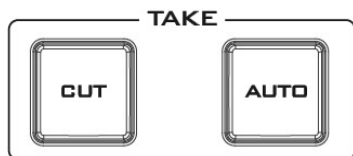
**CUT**

This performs a simple immediate switch from the current main source to the selected sub source. The selected transition wipe or MIX is not used.

**AUTO TAKE**

This performs an automated switch from the current program source to the selected Preview source. The selected transition wipe or MIX will also be used. The timing of the transition is set by the chosen Speed button.

**HEADPHONE** **Headphone Socket**

¼ " / 6.3mm Stereo Headphone Socket for conventional headphones.

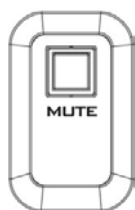
**MUTE**

This button mutes the headphone audio.

**Headphone Volume Control**

Controls Headphone or Headset volume level.

11. Audio Control

## 3.2 Monitor Control Panel

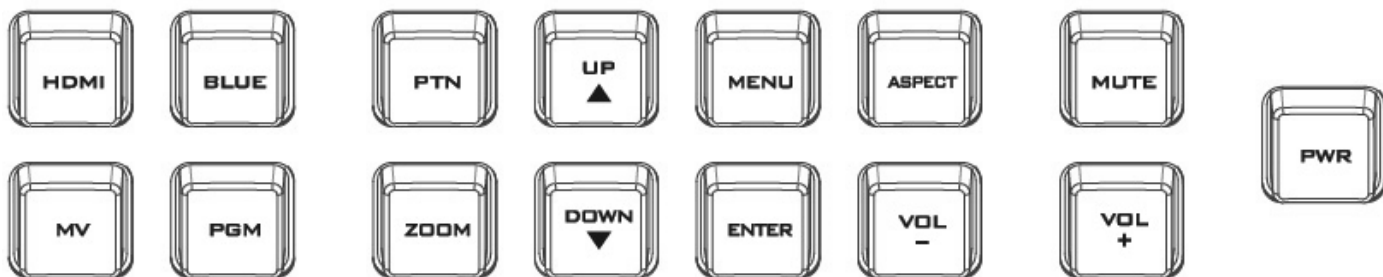

### Power

Switches the HS-1200 Monitor Power ON / OFF

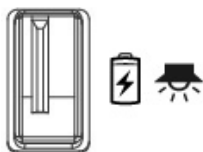

### USB Port

USB port for USB LED Light power supply & 17.3" monitor firmware upgrade.



### Source Select Buttons

Select the type of input you are using - HDMI, MV (multi-view), PGM (program).

### BLUE

Press this button to eliminate the red and green component of input signals. Only the blue component of an input is displayed on the screen. This allows adjustments of chroma and phase. (Phase adjustment is effective with NTSC signals).



### PTN

When pressed displays internally generated SMPTE 75% Colour Bars. Press again to return to the previously selected video input.



### ZOOM

This feature is designed for use with HD-SDI and HDMI sources above 720p resolution. Press this button to zoom in to the video on the display. This is strictly a zooming function and does not alter the native aspect ratio of the source pixels to fill the screen.

The **ZOOM** button allows you to toggle the Pixel Zoom feature between **zoom x1, x2, x4** and **x8**.

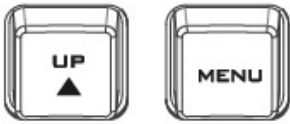

### Menu Navigation Buttons

Display and navigate the set up menus - *See Monitor Menu Options for more details.*



### Aspect Ratio Button

Sets the Aspect Ratio to 16:9 / 4:3

### Volume Control

Adjusts the speaker / headphone volume up / down.

### MUTE

Mutes the audio from the internal speakers or headphone socket.

## 4. Switcher OSD MENU Overview

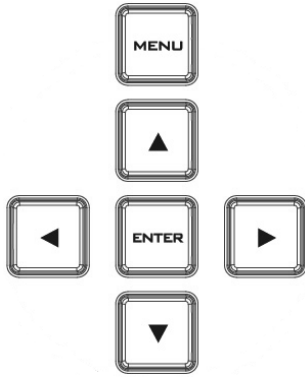

When the **MENU** button is pressed the Main Menu list is displayed on the HDMI 1 Multi-view output.

This section covers the Menu options in the order that they appear on the HS-1200 HDMI 1 Multi-view. These settings may also appear in more detail elsewhere in this instruction manual. Options may vary depending on the firmware version in use.

Once the chosen setting has been confirmed with the **ENTER** button, it is stored within the switcher's non-volatile memory.

Main Options	Sub-Options	Parameters	
Start	Transition (Duration)	M/E	Mix Effect
		DSK	Downstream Key Effect
		FTB	Fade-to-Black Effect
	Type	Clip	
		Wipe	
		Mix	
	Wipe Effects	Wipe	Wipe Effect Presets
		Soft	Border Softness
		Width	Border Width
	Border	Luma	Border Color Luma
		Sat	Border Color Saturation
		Hue	Border Color Hue
	Position	X	Horizontal Position
		Y	Vertical Position
	Matte	Luma	Background Matte Luma
Sat		Background Matte Saturation	
Hue		Background Matte Hue	
Keyer	Keyer	DSK 2	Keyer Selection
		DSK 1	
		Key 2	
		Key 1	
	Keyer Ctrl	Chroma	Type of Keyer
		Luma	
		Linear	
		P-in-P Lite	P-in-P window enable
		P-in-P	P-in-P lite window enable
		Split	Select if two sources are enabled for the keyer (Fill and Key sources)
Self		Select if only one source is enabled for the keyer (Key source)	
Priority (optional and only available when Key 1 and Key 2 are selected)	Bot – Set to bottom layer Top – Set to top layer		
Lift	Parameter for dark/black areas of the overall foreground key image		
Gain	Parameter for light/white areas of the overall foreground		



			key image	
		Opac	Parameter for transparency of the overall foreground key image	
		Bars Matte Input 6 Input 5 Input 4 Input 3 Input 2 Input 1 Black	Key Source Selections	
	Mask	Fill	Fill Source Selection from Bars /Matte /Input 6 /Input 5 /Input 4 /Input 3 /Input 2 /Input 1 /Black	
		Left	Left sets the left edge of the keyer mask	
		Right	Right sets the right edge of the keyer mask	
		Top	Top sets the top edge of the keyer mask	
	Chroma	Keyer	Bottom	Bottom sets the bottom edge of the keyer mask
			DSK 2 (N/A) DSK 1 (N/A) Key 2 Key 1	
			Bars Matte Input 6 Input 5 Input 4 Input 3 Input 2 Input 1 Black	Key Source Selections
CK Setup			CK Auto Hue Luma K Range K Fgnd K Bgnd Hi-Light Lo-Light Bg-Supp	Calculation of the best Hue & Luma values for the current Keyer source Parameter for color of the chroma key Parameter for luma of the chroma key Setting the range of colors that match the background color to be keyed Adjusts the performance of the chroma key in dark or black areas Adjusts the performance of the chroma key in light or white areas Boosts the foreground key in high luminance area Boosts the foreground key in low luminance area Bg-Supp turns ON/OFF background suppress
Mask		Left	Left sets the left edge of the keyer mask	
		Right	Right sets the right edge of the keyer mask	
		Top	Top sets the top edge of the keyer mask	
		Bottom	Bottom sets the bottom edge of the keyer mask	
P-in-P		P-in-P Src	Key 1 / Key 2	Selected in the "Keyer" Option
		Position	X	Horizontal PIP Position
			Y	Vertical PIP Position
			Size	PIP Size
		Border	Luma	PIP Border Luma
Sat			PIP Border Color Saturation	

		Hue	PIP Border Color Hue		
		Width	PIP Border Width		
		Crop	Left	Left Edge of the Crop	
	Right		Right Edge of the Crop		
	Size		Size of the Crop		
	Top		Top Edge of the Crop		
	Bot	Bottom Edge of the Crop			
P-in-P Lite	P-in-P Keyer	Key 1 / Key 2	Selected in the "Keyer" Option		
	Position	X	Horizontal PIP Position		
	Border	Luma	PIP Border Luma		
		Sat	PIP Border Color Saturation		
		Hue	PIP Border Color Hue		
		Width	PIP Border Width		
	Crop	Left	Left Edge of the Crop		
		Right	Right Edge of the Crop		
		Size	Size of the Crop		
		Top	Top Edge of the Crop		
		Bot	Bottom Edge of the Crop		
Inputs	Input 1	Black	Black Level		
		White	White Level		
		Chrom	Chroma Level		
	Input 2	Black	Black Level		
		White	White Level		
		Chrom	Chroma Level		
	Input 3	Black	Black Level		
		White	White Level		
		Chrom	Chroma Level		
	Input 4	Black	Black Level		
		White	White Level		
		Chrom	Chroma Level		
	Freeze	1	Clip	Clip	
			Still	Still	
			Freeze	Freeze	
			Live	Live	
			2	Clip	Clip
				Still	Still
	Freeze	Freeze			
	Live	Live			
	3	Clip		Clip	
Still		Still			
Freeze		Freeze			
Live		Live			
4		Clip	Clip		
		Still	Still		
	Freeze	Freeze			
	Live	Live			
	5	Clip	Clip		
		Still	Still		
Freeze		Freeze			
Live		Live			
6		Clip	Clip		
		Still	Still		
	Freeze	Freeze			
	Live	Live			

	Crosspoint	1	Input 6 Input 5 Input 4 Input 3 Input 2 Input 1 OFF
		2	Input 6 Input 5 Input 4 Input 3 Input 2 Input 1 OFF
		3	Input 6 Input 5 Input 4 Input 3 Input 2 Input 1 OFF
		4	Input 6 Input 5 Input 4 Input 3 Input 2 Input 1 OFF
		5	Input 6 Input 5 Input 4 Input 3 Input 2 Input 1 OFF
		6	Input 6 Input 5 Input 4 Input 3 Input 2 Input 1 OFF
		Outputs	Output
HDMI Output Resolution	1080i 1080p		

	Audio	Mode	ON/OFF	
		Level	EBU SMPTE AUTO	
		SDI 1	SDI 1 Audio Enable (ON)/Disable (OFF)	
		SDI 2	SDI 2 Audio Enable (ON)/Disable (OFF)	
		HDMI	HDMI Audio Enable (ON)/Disable (OFF)	
	GPI Out	ON/OFF	GPI Enable/Disable	
		Mode	Level/Pulse	
		Width	Pulse width	
		Input 1-6	GPI-out assignment	
		Delay	1-99	
	Multiviewer	AutoNum	Auto number input labels (ON/OFF)	
		Label Inf	Input label is followed by information which describes the input as still, live or frozen image (ON/OFF)	
		Trns Lab	Turn the background of the label from a solid colour to transparent (ON/OFF)	
	Stills	Load Still	Load	Pressing this button loads the selected still picture source
			Still Memory Location	0-500
Destination			Input6 Input5 Input4 Input3 Input2 Input1	
Thumbnail Picture - 1			Preview of the previous image	
Thumbnail Picture			Preview of the image to be loaded	
Thumbnail Picture + 1			Preview of the next image	
Save Still			Save	Pressing this button saves the selected still picture
		Source	Input6 Input5 Input4 Input3 Input2 Input1	
		Still Memory Location	0-500	
Freeze		1	Sets the Frame store mode of Input 1 to Clip/Still/Freeze/Live	
		2	Sets the Frame store mode of Input 2 to Clip/Still/Freeze/Live	
		3	Sets the Frame store mode of Input 3 to Clip/Still/Freeze/Live	
		4	Sets the Frame store mode of Input 4 to Clip/Still/Freeze/Live	
		5	Sets the Frame store mode of Input 5 to Clip/Still/Freeze/Live	
		6	Sets the Frame store mode of Input 6 to Clip/Still/Freeze/Live	
User Mem	Load Mem	Memory	Memory Selections from 1 to 999	
		Load	Selection of this button loads the selected memory	
	Save Mem	Memory	Memory Selections from 1 to 999	
		Save	Selection of this button saves to the selected memory	

Setup	Standard	1080i/50	Resolution Selections from 1080i/50/59.94/60 720p/60/59.94/50
		Save Setup	Saves the selected resolution
	Menu Mode	Advanced	
		Basic	
	Menu Pref	Blue / Grey	Selection of menu color
		Transp	Menu transparency level of 0/1/2
		Size	Menu size of Normal/Small/Large
	Menu Pos	Bottom Right Left Top Centre	This option sets the menu position
	Auto Save	ON / OFF	Automatically saves the last settings before the machine is shut down; once turned ON auto save also occurs upon every Still Load.
	Factory Def	Reset	Factory Default Reset loads the default configuration from memory point 0 for all configuration options except for the Setup.
		Reset Names	Resets the Multiviewer labels to the default settings
	Language	English Traditional Chinese Simplified Chinese	
	Software	Upgrade	This starts the FW upgrade process Please refer to the <a href="#">Firmware Upgrade</a> section for the USB firmware update process.

## 5. Switcher OSD MENU Functions

The HS-1200 HD 6-Channel Portable Video Studio offers the user an OSD menu to perform several image effect configurations, such as Picture-in-Picture, keyers, downstream keys, still pictures and etc. The user can also configure the I/O by selecting the Inputs and Outputs options. In addition, under the setup options, the user is allowed to set the menu color, size, position and language.

The OSD Menu also gives the user the flexibility to switch between basic and advanced modes. The basic mode is generally a condensed version of the advanced menu mode. The following sections will show you the options available in these two modes.

### 5.1 Start

The “Start” option generally allows the user to set the Transition duration, the Transition type, and various WIPE effect parameters. The OSD menu display is illustrated in the table below.

#### Advanced Mode

Start	Transition	M/E	60	DSK	60	FTB	60
Keyer	Type	Wipe					
Chroma							
P-in-P	Wipe Effects	Wipe	1	Soft	0%	Width	0%
P-in-P Lite	Border	Luma	100%	Sat	80%	Hue	178
Inputs	Position	X	0%	Y	0%		
Outputs							
Stills	Matte	Luma	100%	Sat	80%	Hue	0
User Mems							
Setup							

#### Basic Mode

Start	Transition	M/E	60	DSK	60	FTB	60
Keyer							
Chroma	Wipe Effects	Wipe	1	Soft	0%	Width	0%
P-in-P							
P-in-P Lite							
Inputs							
Outputs							
Stills							
User Mems							
Setup							

#### Transition

The transition option allows the user to set the transition duration, in frames, for switching to the PGM view when using the **AUTO**, **DSK** and **FTB** buttons. The sub-options are (AUTO) Mix Effect (**M/E**), Downstream Key (**DSK**) and Fade-To-Black (**FTB**). If the M/E is set to a value of 50 then the transition will take effect over a period of 50 frames or roughly 2 seconds. When the **AUTO button** is pressed, the transition will take the current M/E value.

The three available transition types (**Type**) are **Clip/Wipe/Mix**.

#### Wipe Effects

This sub-option allows the user to select the desired Wipe Transition Effect and configure the wipe’s border softness and width.

- **Wipe** – Wipe Effect Selection.
- **Soft** – A low value results in a solid edge border and a high value gives a soft diffused border.
- **Width** – A low value results in a thin border and a high value gives a wide border.

### **Border**

After selecting this sub-option, the user will then be allowed to fine-tune the border color by adjusting the Luma, Saturation and Hue values, i.e. Luma, Sat and Hue.

### **Position**

Position allows the user to adjust the centre position of some wipes (e.g Circle & Ellipse). X represents the horizontal position and Y represents the vertical position.

<b>X</b>	<b>Y</b>
Positive value: position the wipe centre to the right Negative value: position the wipe centre to the left Zero value: Position the wipe centre at the screen centre	Positive value: move the wipe centre up Negative value: move the wipe centre down Zero value: Position the wipe centre at the screen centre

### **Matte**

The user can configure the Matte Luma, Saturation and Hue under this sub-option.

## **5.2 Keyer**

In this option, the user is able to configure four keyers, which are **Key 1**, **Key 2**, **DSK 1** and **DSK 2**.

### **Advanced Mode = Basic Mode**

Start	<b>Keyer</b>	Key 1		
<b>Keyer</b>				
Chroma	<b>Keyer Ctrl</b>	Chroma	P-in-P	<b>Priority</b> Bot
P-in-P		<b>Lift</b> 0%	<b>Gain</b> 1.0	<b>Opac</b> 100%
P-in-P Lite	<b>Key Source</b>	Input 1	<b>Fill</b> Input 3	
Inputs				
Outputs	<b>Mask</b>	<b>Left</b> 0%	<b>Right</b> 0%	
Stills		<b>Top</b> 0%	<b>Bot</b> 0%	
User Mems				
Setup				

### **Keyer Control**

There are three keying modes available: **Linear**, **Luma**, and **Chroma**.

After the keying mode is chosen, select **Self** if only one source is enabled for the keyer, which is **Key** source and select **Split** if two sources are enabled for the keyer, which are **Key** and **Fill** sources. You may also select **P-in-P** or **P-in-P Lite** to apply the keying effect to the P-in-P window.

**Please note:**

**If Luma is selected, fine tune the Luma Keyer parameters (Lift, Gain and Opac) in the Keyer option.**

**If Chroma is selected, fine tune the Chroma Keyer parameters in the Chroma option.**

**If P-in-P is selected, fine tune its parameters in the P-in-P option.**

**If P-in-P Lite is selected, fine tune its parameters in the P-in-P Lite option.**

For example, if the user selects **Key 1** → **Chroma** → **P-in-P**, you will be performing chromakeying of the P-in-P image after the relevant chroma keyer parameters are adjusted in the **Chroma** option.

**Priority** sets the key image to either the top layer or bottom layer and is only available if **Key 1** or **Key 2** is selected.

The Keyer Control also allows the user to adjust lift, gain and opacity of the key image.

**Lift** adjusts the dark/black areas of the key image.

**Gain** adjusts the light/white areas of the key image.

**Opacity** adjusts the transparency of the overall foreground key image.

### Key Source

This sub-option allows the user to assign the key source; various options are listed below:

Bars	Matte	Input6	Input5	Input4	Input3	Input2	Input1	Black
------	-------	--------	--------	--------	--------	--------	--------	-------

### Fill Source

This sub-option allows the user to assign the fill source if **Split** is selected; various options are listed below:

Bars	Matte	Input6	Input5	Input4	Input3	Input2	Input1	Black
------	-------	--------	--------	--------	--------	--------	--------	-------

### Mask

The Mask feature allows the user to configure the Mask in chroma, luma or linear mode.

- Left – Left sets the left edge of the keyer mask.
- Right – Right sets the right edge of the keyer mask.
- Top – Top sets the top edge of the keyer mask.
- Bottom – Bottom sets the bottom edge of the keyer mask.

## 5.3 Chroma

In this option, the user will be able to find all the parameters needed to perform chromakeying of the green backdrop.

### Advanced Mode = Basic Mode

Start	<b>Keyer</b>	<b>Key 1</b>			
Keyer	<b>Key Source</b>	<b>Input 5</b>			
<b>Chroma</b>					
P-in-P	<b>CK Setup</b>	<b>CK Auto</b>	<b>Hue</b> 120	<b>Luma</b> 100%	
P-in-P Lite		<b>KRange</b> 170	<b>K Fgnd</b> 15%	<b>K Bgnd</b> 67%	
Inputs		<b>Hi-Light</b> 0%	<b>Lo-Light</b> 0%	<b>Bg-Supp</b> On	
Outputs					
Stills	<b>Mask</b>	<b>Left</b> 0%	<b>Right</b> 0%		
User Mems		<b>Top</b> 0%	<b>Bot</b> 0%		
Setup					

### Keyer

First of all, select the **Keyer** that you would like to enable for the chromakeyer (**Key 1**, or **Key 2**) and then select one Key Source from all available **Key Sources** listed in the table below.



Bars	Matte	Input6	Input5	Input4	Input3	Input2	Input1	Black
------	-------	--------	--------	--------	--------	--------	--------	-------

### CK Setup

In this sub-option, the user will be able to fine tune various chroma keyer parameters.

**CK Auto:** This function calculates the best Hue & Luma values for the current Key Source.

**Hue:** This parameter adjusts the color of the chroma key. A typical green screen value will be around 120. Blue screen value will be around 240.

**Luma:** This parameter adjusts the luma value of the chroma key

**Key Range (KRange):** Key Range sets the range of hues or colors (0 – 360 degrees) that closely match the background color to be keyed. The user can start with a value of 120 degrees and this value can be fine-tuned up or down depending on the setup of the green or blue screen studio.

**Key Foreground (K Fgnd):** Key Foreground adjusts the performance of the chroma key in dark or black areas. Increase the value if the dark areas are becoming too transparent.

**Key Background (K Bgnd):** Key Background adjusts the performance of the chroma key in light or white areas. Increase the value if the light areas are becoming too transparent.

**Hi-Light:** Hi-light boosts the foreground key in high luminance area.

**Lo-Light:** Lo-light boosts the foreground key in low luminance area.

**Bg-Supp:** Background Suppress removes the Luma (Brightness) of the background from the final image. Bg-Supp turns ON/OFF background suppression.

### Mask

The Mask feature allows the user to configure the Mask in chroma mode.

- Left – Left sets the left edge of the Chroma keyer mask.
- Right – Right sets the right edge of the Chroma keyer mask.
- Top – Top sets the top edge of the Chroma keyer mask.
- Bottom – Bottom sets the bottom edge of the Chroma keyer mask.

## 5.4 P-in-P

**P-in-P** option allows the user to adjust all related P-in-P parameters. Enter this option if the user selects **P-in-P** in the **Keyer** option. “**P-in-P Scr**” sub-option will indicate the keyer enabled for P-in-P. In our example below, the **Key 1** keying effect will be applied to the P-in-P window.

**Please note** that the “**P-in-P Scr**” sub-option can only be changed in the **Keyer** option.

### Advanced Mode = Basic Mode

Start	<b>P-in-P Src</b>	<b>Key 1</b>					
Keyer	<b>Position</b>	<b>X</b>	20%	<b>Y</b>	10%	<b>Size</b>	50%
Chroma	<b>Border</b>	<b>Luma</b>	0%	<b>Sat</b>	0%	<b>Hue</b>	0
<b>P-in-P</b>		<b>Width</b>	0%				
P-in-P Lite							
Inputs	<b>Crop</b>	<b>Left</b>	0%	<b>Right</b>	0%	<b>Size</b>	0%
Outputs		<b>Top</b>	0%	<b>Bot</b>	0%		
Stills							

User Mems				
Setup				

### Position

The user can adjust the P-in-P window position by adjusting values of **X**, **Y** and **SIZE**, where X is the horizontal position, Y is the vertical position and Size is the P-in-P window size.

X	Y	Size
Positive value: position the P-in-P window to the right. Negative value: position the P-in-P window to the left. Zero value: Position the P-in-P window at the center.	Positive value: move the P-in-P window up. Negative value: move the P-in-P window down. Zero value: Position the P-in-P window at the center.	Ranges from 0 to 100 with 1% being the smallest and 100 being the largest. So 50% would represent a P-in-P window which is half the size of the background image. 100% would see the PIP image totally cover the background image unless offset to one side.

### Border

P-in-P window border color can be set by adjusting the **Luma**, **Saturation** and **Hue** values.

### Border Width

The “**Width**” sub-option adjusts the border width. A width of zero (0) will turn the P-in-P window border off.

### Crop

The P-in-P window crop can be adjusted by modifying the following parameters:

- **Left** – Adjusts the position of the left edge of the P-in-P window.
- **Right** – Adjusts the position of the right edge of the P-in-P window.
- **Size** – Adjusts the P-in-P window crop size.
- **Top** – Adjusts the position of the top edge of the P-in-P window.
- **Bot** – Adjusts the position of the bottom edge of the P-in-P window.

## 5.5 P-in-P Lite

**P-in-P Lite** option allows the user to adjust related P-in-P parameters **EXCEPT** its vertical position and the **P-in-P** window size. Enter this option if the user selects **P-in-P Lite** in the **Keyer** option. “**P-in-P Keyer**” sub-option will indicate the keyer enabled for P-in-P Lite. In our example below, the **Key 1** keying effect will be applied to the P-in-P Lite window.

**Please note** that the “**P-in-P Keyer**” sub-option can only be changed in the **Keyer** option.

### Advanced Mode = Basic Mode

Start	P-in-P Keyer	Key 1				
Keyer	<b>Position</b>	<b>X</b>	-22%			
Chroma	<b>Border</b>	<b>Luma</b>	100%	<b>Sat</b>	80%	<b>Hue</b> 0
P-in-P		<b>Width</b>	2%			
<b>P-in-P Lite</b>						
Inputs	<b>Crop</b>	<b>Left</b>	32%	<b>Right</b>	22%	<b>Size</b> 0%
Outputs		<b>Top</b>	2%	<b>Bot</b>	24%	
Stills						

User Mems				
Setup				

### Position

The user can adjust the horizontal position of the P-in-P window by adjusting the **X** value.

- Positive X value positions the P-in-P window to the right.
- Negative X value positions the P-in-P window to the left.
- Zero X value positions the P-in-P window at the center.

### Border

P-in-P window border color can be set by adjusting the **Luma, Saturation and Hue** values.

### Border Width

The “**Width**” sub-option adjusts the border width. A width of zero (0) will turn the P-in-P window border off.

### Crop

The P-in-P window crop can be adjusted by modifying the following parameters:

- **Left** – Adjusts the position of the left edge of the P-in-P window.
- **Right** – Adjusts the position of the right edge of the P-in-P window.
- **Size** – Adjusts the P-in-P window crop size.
- **Top** – Adjusts the position of the top edge of the P-in-P window.
- **Bot** – Adjusts the position of the bottom edge of the P-in-P window.

## 5.6 Inputs

This feature allows the user to configure the color of the Inputs 1-4. In addition, the user can shuffle the contents between Inputs 1-6 or turn off the input channel.

### Advanced Mode

Start	<b>Input 1</b>	<b>Black</b>	0%	<b>White</b>	100%	<b>Chrom</b>	1.0
Keyer	<b>Input 2</b>	<b>Black</b>	0%	<b>White</b>	100%	<b>Chrom</b>	1.0
Chroma	<b>Input 3</b>	<b>Black</b>	0%	<b>White</b>	100%	<b>Chrom</b>	1.0
P-in-P	<b>Input 4</b>	<b>Black</b>	0%	<b>White</b>	100%	<b>Chrom</b>	1.0
P-in-P Lite							
<b>Inputs</b>	<b>Freeze</b>	<b>1</b>	Still	<b>2</b>	Live	<b>3</b>	Still
Outputs		<b>4</b>	Still	<b>5</b>	Still	<b>6</b>	Live
Stills							
User Mems	<b>Crosspoint</b>	<b>1</b>	Input 1	<b>2</b>	Input 2	<b>3</b>	Input 3
Setup		<b>4</b>	Input 4	<b>5</b>	Input 5	<b>6</b>	Input 6

### Basic Mode

Start	<b>Freeze</b>	<b>1</b>	Still	<b>2</b>	Live	<b>3</b>	Still
Keyer		<b>4</b>	Still	<b>5</b>	Still	<b>6</b>	Live
Chroma							
P-in-P	<b>Crosspoint</b>	<b>1</b>	Input 1	<b>2</b>	Input 2	<b>3</b>	Input 3
P-in-P Lite		<b>4</b>	Input 4	<b>5</b>	Input 5	<b>6</b>	Input 6
<b>Inputs</b>							

Outputs				
Stills				
User Mems				
Setup				

### **Input 1-4**

By selecting the corresponding input (Inputs 1-4), the user will then be allowed to configure the colour of the inputs 1-4 by adjusting its Black Level, White Clip and Chroma Gain parameters.

### **Freeze**

“Freeze” allows the user to load an image to **Inputs 1-6** from one of the four sources listed as follows:

- **Clip**
- **Still**
- **Freeze**
- **Live**

### **Crosspoint**

Crosspoint gives the user the ability to shuffle the contents between Inputs 1-6. In other words, the user will be able to assign any of the sources of Inputs 1-6 to the 6 input buttons (1, 2, 3, 4, 5 and 6) of the Program and Preset rows as desired.

## **5.7 Outputs**

This option allows the user to configure various output settings such as video output, audio output, and GPI Out.

### **Advanced Mode**

Start	<b>Output</b>	<b>Sdi 1</b>	Pgm	<b>Sdi 2</b>	Input 2	<b>HDMI</b>	MultiV
Keyer						<b>HDMI</b>	1080P
Chroma	<b>Audio</b>	<b>Mode</b>	On	<b>Level</b>	Auto		
P-in-P		<b>Sdi 1</b>	On	<b>Sdi 2</b>	On	<b>HDMI</b>	On
P-in-P Lite							
Inputs	<b>GPI Out</b>	Off		<b>Mode</b>	Pulse	<b>Width</b>	1
<b>Outputs</b>		Input 1		<b>Delay</b>	0		
Stills							
User Mems	<b>MultiViewer</b>	<b>AutoNum</b>	Off	<b>Label Inf</b>	Off	<b>Trns Lab</b>	Off
Setup							

### **Basic Mode**

Start	<b>Output</b>	<b>Sdi 1</b>	Pgm	<b>Sdi 2</b>	Input 2	<b>HDMI</b>	MultiV
Keyer						<b>HDMI</b>	1080P
Chroma	<b>Audio</b>	<b>Mode</b>	On	<b>Level</b>	Auto		
P-in-P		<b>Sdi 1</b>	On	<b>Sdi 2</b>	On	<b>HDMI</b>	On
P-in-P Lite							
Inputs							
<b>Outputs</b>							
Stills							
User Mems							
Setup							

## **Outputs**

In general, there are three output ports (**SDI 1**, **SDI 2** and **HDMI**) available, which can be configured to output one of the following:

- Input 6
- Input 5
- Input 4
- Input 3
- Input 2
- Input 1
- CLN PVW (Clean PVW)
- CLN PGM (Clean PGM)
- PG + DSK
- PVW
- PGM
- MultiV (Multi view)

In addition to selecting your output source, you are also allowed to set two different resolutions to the HDMI output port. The two available resolutions are 1080i and 1080p.

Please note that when HDMI OUT is set to 1080i, image will be enlarged on the DELL 24" monitor (Wide Mode = 1:1), exceeding the viewable screen area (overscan). In 1080p and 720p modes, image overscan and shifts are seen on BENQ 37"/SONY 42" TV.

## **Audio**

The Audio sub-option for the SDI and HDMI outputs allows the user to individually turn ON/OFF the embedded audio component at the **SDI1-out**, **SDI2-out** and **HDMI-out**.

**Mode** (On/Off): The HS-1200 can only accept external audio using the analogue XLR inputs on the rear panel. Ideally a master audio mixer would be used alongside the HS-1200. A Datavideo AM-100 or AD-200 could be considered. By changing the Audio sub option from ON to OFF will mute the incoming XLR audio from the external master audio mixer.

**Level** (EBU/SMPTE/AUTO): There are two different audio standards available for selection. The user can either select the EBU or SMPTE standard. By selecting AUTO allows the device to automatically detect the audio standard.

## **GPI Out**

This allows the user to perform GPI configuration. After turning on the GPI, select the GPI **mode**, which is either level or pulse. The pulse width can also be configured in the sub-option **Width** (1-9). GPI out can then be assigned to one of Inputs 1-6 and the **delay** can be set to between 1 and 99. This feature could be used to trigger playback from an external playback device such as Datavideo's NVP-20 or HRS-30 unit.

## **Multiviewer**

**AutoNum**: The Multiview windows can be automatically numbered, and this sub-option turns ON/OFF automatic numbering.

**Label Inf**: This sub-option turns ON/OFF Label information. Input label is followed by information which describes the input as still, live or frozen image.

**Trns Lab**: This sub-option turns ON/OFF Label Transparency. Once enabled, the background of the label is then turned from a solid colour to transparent.

## 5.8 Stills

Still allows the user to load images from the memory, save images to the memory, and save the images captured.

### Advanced Mode

Start	<b>Load Still</b>	<b>Load</b>	<b>Still Num</b> 13	<b>Input 5</b>
Keyer		<b>Thumbnail Picture - 1</b>	<b>Thumbnail Picture</b>	<b>Thumbnail Picture + 1</b>
Chroma				
P-in-P				
P-in-P Lite	<b>Save Still</b>	<b>Save</b>	<b>Input 5</b>	<b>Still Num</b> 13
Inputs				
Outputs	<b>Freeze</b>	<b>1</b> Still	<b>2</b> Live	<b>3</b> Still
<b>Stills</b>		<b>4</b> Still	<b>5</b> Still	<b>6</b> Live
User Mems				
Setup				

### Basic Mode

Start	<b>Load Still</b>	<b>Load</b>	<b>Still Num</b> 13	<b>Input 5</b>
Keyer		<b>Thumbnail Picture - 1</b>	<b>Thumbnail Picture</b>	<b>Thumbnail Picture + 1</b>
Chroma				
P-in-P				
P-in-P Lite	<b>Save Still</b>	<b>Save</b>	<b>Input 5</b>	<b>Still Num</b> 13
Inputs				
Outputs				
<b>Stills</b>				
User Mems				
Setup				

### Load Still

Upon selecting “Load Still”, the user can then choose the memory location from which the still image is loaded. The following are the destinations to which the still image can be loaded:

- **Input 6**
- **Input 5**
- **Input 4**
- **Input 3**
- **Input 2**
- **Input 1**

Select “Load” to load the still image to the determined destination.

**Image Preview** is available below the “Load Still” row. “**Image Preview – 1**” allows the user to preview the previous image, “**Image Preview**” displays the image that will be loaded when “Load” is selected, and “**Image Preview + 1**” shows the next image.

### Save Still

“Save Still” allows the user to save the still image to a specific memory location. The user should determine the source of the still image first. The available sources are listed below:

- **Input 6**
- **Input 5**
- **Input 4**
- **Input 3**

- **Input 2**
- **Input 1**

To complete the save, the user can simply select “**Save**” after determining the memory location.

### **Freeze**

“Freeze” allows the user to load an image to **Inputs 1-6** from one of the four sources listed as follows:

- **Clip**
- **Still**
- **Freeze**
- **Live**

## **5.9 User Mems**

In this option, the user is allowed to **load** previously saved settings and **save** the currently configured settings.

### **Advanced Mode = Basic Mode**

Start	<b>Load Mem</b>	<b>Memory</b>	<b>1</b>	<b>Load</b>	
Keyer					
Chroma	<b>Save Mem</b>	<b>Memory</b>	<b>1</b>	<b>Save</b>	
P-in-P					
P-in-P Lite					
Inputs					
Outputs					
Stills					
<b>User Mems</b>					
Setup					

### **Load Memory**

Use the up/down arrow to scroll to the desired memory location (**1-999**) and load the saved setting by selecting “Load”. The user can also press one of the USER memory shortcut buttons (1-6) on the control panel as a quick way of loading those previously saved User configurations.

### **Save Memory**

Use the up/down arrow to scroll to the desired memory location and save the current setting by selecting “Save”

## **5.10 Setup**

In the “Setup” menu, the user can change the **resolution**, switch between full and simplified menu versions, adjust the **menu preferences**, enable/disable **Auto Save**, reset the machine to its **Factory Default** settings, choose the preferred OSD menu **language**, **upgrade firmware** and view the **current firmware versions** (Interface, Mainboard and Keyboard).

Start	<b>Standard</b>	1080i/59.94	<b>Save Setup</b>	
Keyer	<b>Menu Mode</b>	Advanced		
Chroma	<b>Menu Pref</b>	Blue	<b>Transp</b>	<b>1</b> <b>Size</b> Normal
P-in-P	<b>Menu Pos</b>	Centre		
P-in-P Lite				
Inputs	<b>Auto Save</b>	On		

Outputs	<b>Factory Def</b>	Reset	<b>Reset Names</b>	
Stills	<b>Language</b>	English		
User Mems				
<b>Setup</b>	HS-1200	S/W: v1.2.2.8	F/W: 2016-03-15	KBD: v2.26

### ***Menu Preference***

In menu preference, the user is allowed to set the menu color, menu transparency level, menu size and the display position.

**Menu color:** the available colors are blue and grey

Options of **Menu Transparency** are listed below:

0: No Transparency

1: Background 50% Transparent (buttons not Transparent)

2: All Menu 50% Transparent

### **Menu Size**

The menu size options are:

1. Normal

2. Small (1080i Mode)

3. Large (720p Mode)

### **Menu Position**

Menu Position gives the user ability to select several positions for the Menu area on the Screen. The current options are Centre, Top, Left, Right and Bottom.

### ***Standard***

This option allows the user to choose the appropriate output resolution such as 1080i/50. Once done, simply select "**Save Setup**" to confirm the selected output resolution. The available resolutions are 1080i/50/59.94/60, 720p/60/59.94/50.

### ***Menu Mode***

The user is allowed to switch between full and simplified menu versions. Select "Advanced" for full menu display or "Basic" to display a simplified version of the OSD menu.

### ***Auto Save***

When enabled, your last settings will be automatically saved before the machine is shut down. At the next boot, the machine will automatically load the last saved settings. In addition, a Still Load will cause the auto save to occur.

### ***Factory Default***

**Reset:** This option resets the machine to the factory default settings by loading the default configuration from memory point 0 for all configuration options except for the **Setup**.

### ***Reset Names***

This resets the Multiviewer labels (Inputs 1-6) to their default settings.



## ***Language***

The available languages for OSD menu are English, Traditional Chinese and Simplified Chinese.

## ***Software***

This option is only available when the USB storage device containing the latest firmware file is inserted. Select Upgrade to start the firmware upgrade process. Refer to the [FIRMWARE UPDATE](#) section for more details.

At the bottom of the menu, you will be able to view the version number of the latest firmware installed.

## 6. Monitor OSD MENU Options



The HS-1200 Monitor can be configured via an on screen menu. When the **MENU** button is pressed the Main Menu list is displayed on the monitor.



This section covers the Menu options in the order that they appear on the monitor. These settings may also appear in more detail elsewhere in this instruction manual. Options may vary depending on the firmware version in use.

Once the chosen setting has been confirmed with the **ENTER** button, it is stored within the switcher's non-volatile memory.

Main Options	Sub Options	Parameters	Parameters
MAIN ADJUST	BRIGHTNESS	0~100	
	CONTRAST	0~100	
	SHARPNESS	0~100	
	SATURATION	0~100	
	TINT	0~100	
	BACK LIGHT	0~100	
	NR	HIGH / MID / LOW / OFF	
	MPEG NR	HIGH / LOW / OFF	
	VOLUME	0~100	
	EXIT		
COLOR	6500		
	9300		
	7500		
	USER COLOR	RED	0~100
		GREEN	0~100
BLUE		0~100	
EXIT			
SCAN SETTING	UNDER SCAN	full image	
	OVER SCAN	cropped image	
INFORMATION	H. FREQUENCY		
	V. FREQUENCY		
	RESOLUTION		
	VER.		
LANGUAGE	English [default]		
	Francis		
	Deutsch		
	Español		
	Italiano		
	Dutch		
	Português		
	Russian		
EXIT			
SPECIAL FUNCTION	OSD TIMOUT	5-120 SEC	
	FRAME RATIO	80 / 90 / OFF	
	4:3 MARK LINE	ON / OFF	
	CENTRAL MARK	ON / OFF	
	CINEMA ZONE MARK	ON / OFF	
	EXIT		
FACTORY RESET			
EXIT			

## 7. Firmware Update Procedure

From time to time Datavideo may release new firmware to either add new features or to fix reported bugs in the current HS-1200 firmware. Customers can update the firmware themselves if they wish or they can contact their local dealer or reseller for assistance should they prefer this method.

This page describes the firmware update process and it should take *approximately few minutes to complete*.

**As well as a working HS-1200 you will need:**

- The latest firmware update for the **HS-1200** (This firmware file can be obtained from your local Datavideo office or dealer).
- USB 2.0 pen drive
- A USB A connector cable.

Once started *the update process should not be interrupted in any way* as this could result in a non-responsive unit.

1. Locate the FW Upgrade USB port on the front panel of the HS-1200.



2. Insert the USB stick that contains the latest firmware to the FW upgrade port.
3. Power on the device and the device should automatically detect the connected USB storage device.
4. Press the “**MENU**” button on the control panel to open the menu on the monitor screen.
5. Press the “**down arrow**” button to scroll to the “**Setup**” Option.
6. Press the “**ENTER**” button to enter the “**Setup**” menu.
7. Press the “**down arrow**” button to scroll to the “**Software**” Sub-option and then press the “**ENTER**” button to select the “**Software**” Sub-option.
8. At this point, back color of the “**Upgrade**” box should turn green and then press the “**ENTER**” button again to start the upgrade process (back color turns red).
9. After the upgrade is finished, the back color will then turn back to orange.
10. Reboot the device after the upgrade process is complete.

## 8. GPI Connection

The HS-1200 can control external recorder/playback devices via simple contact closure GPI switch.

The GPI interface is a 3.5mm Jack Socket which is situated on the rear panel of the HS-1200. Contact closure between the Outer and Inner contacts on the jack plug will trigger a user selected event. Power is supplied by the HS-1200 and is less than 5V DC.

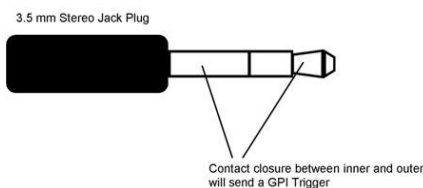

This GPI socket can also be used as a socket to trigger record or playback events with other equipment such as the Datavideo HDR-70 recorder.

**SAFETY FIRST** The cabling required needs to be designed specifically to connect the HS-1200 to the chosen record or playback device as they are not all the same. The cabling required can be made by yourself or a competent technician. Please speak with your Dealer or local Datavideo office to get further help and advice.

## 9. Tally Outputs

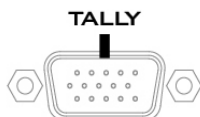

The HS-1200 has a D-sub 15 pin female tally output port. These connections provide bi-colour tally information to a number of other Datavideo products, such as the ITC-100 eight channel talkback system and the TLM range of LCD Monitors. The ports are open collector ports and as such do not provide power to tally light circuits.

The pin outputs are defined as follows:

PIN No.	Signal Name	Input/Output	Description of Signal
1	Program 1	Open collector output	Tally output of input video Program 1
2	--	--	No Function
3	Preview 1	Open collector output	Tally output of input video Preview 1
4	RCOM (GND)	Ground	Ground
5	Program 4	Open collector output	Tally output of input video Program 4
6	Program 2	Open collector output	Tally output of input video Program 2
7	--	--	No Function
8	Preview 2	Open collector output	Tally output of input video Preview 2
9	GND	Ground	Ground
10	--	--	No Function
11	Program 3	Open collector output	Tally output of input video Program 3
12	--	--	No Function
13	Preview 3	Open collector output	Tally output of input video Preview 3
14	YCOM (GND)	Ground	Ground
15	Preview 4	Open collector output	Tally output of input video Preview 4

# 10. Dimensions

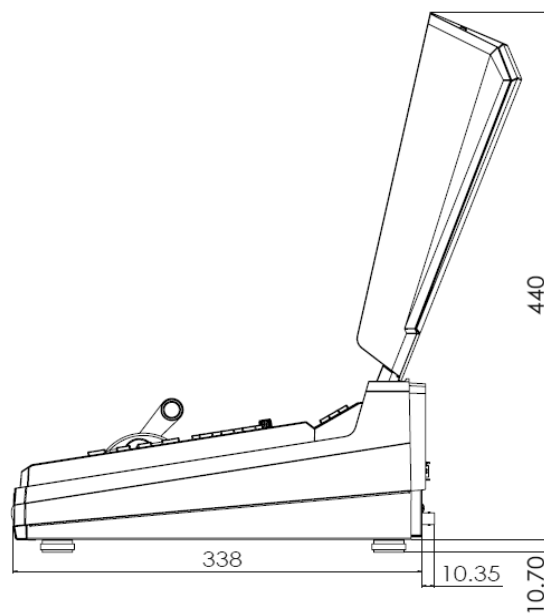
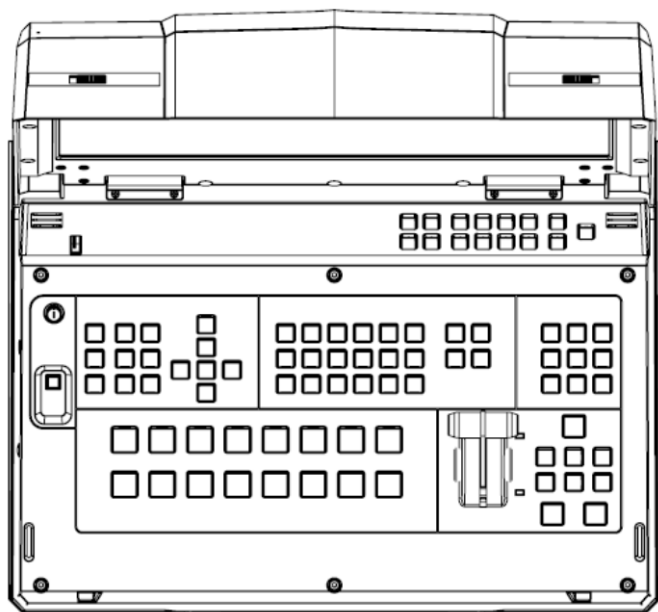
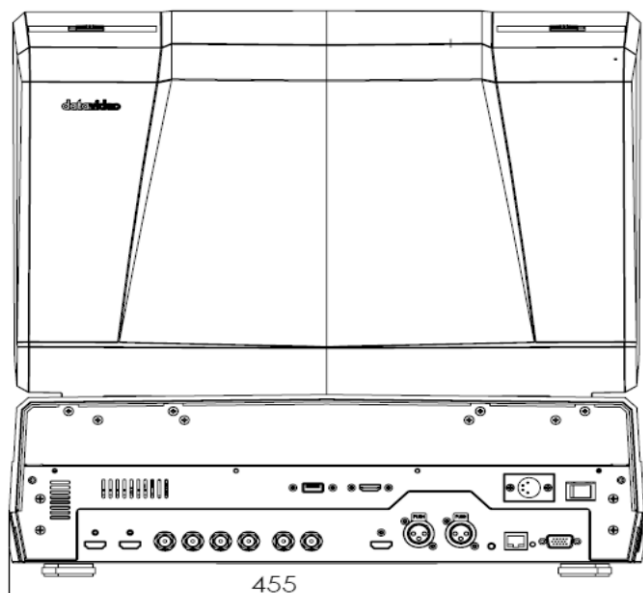

All measurements in millimetres (mm)

# 11. Specifications

<b>Connections</b>	
Total Video Inputs	Total 6 inputs 2 HDMI (RGB/YVU, 1080P/1080I/720P) 4 SDI (1080I/720P)
Monitor External Input	1 HDMI (to Monitor)
Total Outputs	1 HDMI + 1 SDI
SDI Audio Output (PGM output)	2CH
Audio Input	2 x XLR (2 x Analogue)
Internal Frame Synchronizers	All 6 Inputs
PGM Out	HDMI / SDI
Multi view Out	HDMI (720P -> 720P ; 1080i->1080P) SDI (720P -> 720P ; 1080i->1080i)
Output can select any of input source	PROGRAM (w/ DSK 1 & 2) PROGRAM (w/ DSK1) Clean PROGRAM PREVIEW ( w/o DSK) MULTISCREEN Input 1~6
Audio Indicator on Multi view	Y ( output 2CH)
Computer Output	Ethernet (Motion JPEG Out)
Control Panel Connection	RS-232
Tally Out	Y
GPI	Two mode: Level /Pulse trigger selectable
Speaker Volume Control	Control Knob
Software Updates	Ethernet
<b>Monitor</b>	
LCD Display	17.3" TFT LCD
Resolution	RGB 1600 x 900 pixel
Aspect Ratio	4:3 and 16:9 selectable
LED Life time	12,000 hrs. (approx.)
Brightness (Luminance)	220 cd/m <sup>2</sup>
Contrast Ratio	500:1
View Angle	Top : 40 deg / Bottom : 60 deg Left : 60 deg / Right : 60 deg
Video System	NTSC / PAL auto recognition
Colour Adjustment	Brightness, Contrast, Color Saturation
<b>Standards</b>	
Format Support	1080i 50/ 59.94/ 60Hz, 720p 50/ 59.94/ 60Hz,
SDI Compliance	SMPTE 292M.( SDI output /PGM out)

Video Sampling	4:2:2 10 bit
Color Precision	4:2:2 10 bit
Color Space	4:2:2 YUV
HDMI Input Resolutions for Computers	1280 x 720 59.94Hz 50Hz (720P) and 1920 x 1080 59.94Hz 50Hz (1080p & 1080i)
<b>Processing</b>	
Colorspace Conversion	Hardware based real time
Processing Delay	< 1 frame
Audio Mixer	Selectable audio follow video Master gain control
HD Down Conversion	N/A
<b>Extras</b>	
Upstream Keyers	2 (M/E Keyer & PIP)
Downstream Keyers	2
Linear/Luma Keyers	4
Chroma Keyers	2 (M/E Keyer & PIP)
Pattern Generators	Color Bar
PIP	1
XPT	Y
Frame store	Any Input can be used as Frame store. 8 Still frames stored in local frame buffers for instant access.
Control Panel Compatibility	Use PC via Ethernet; Control Panel
Input Voltage	8V~17V
<b>Multi View Monitoring</b>	
Number of Windows	2 (PGM, PVW) +6 (Inputs 1-6) +2 Output windows (SDI1, SDI2)
Routable Windows	Y (Follow XPT)
Tally	Y
Windows Source Labels	Y

# Service & Support

It is our goal to make owning and using Datavideo products a satisfying experience. Our support staff is available to assist you to set up and operate your system. Contact your local office for specific support requests. Plus, please visit [www.datavideo.com](http://www.datavideo.com) to access our FAQ section.

## Datavideo Taiwan

Datavideo Technologies Co. Ltd  
10F. No. 176, Jian 1st Rd., Chung Ho  
District, New Taipei City 235, Taiwan,  
R.O.C.  
Tel: +886-2-8227-2888  
Fax: +886-2-8227-2777  
E-mail: [service@datavideo.com.tw](mailto:service@datavideo.com.tw)

## Datavideo Europe

Datavideo Technologies Europe BV  
Floridadreef 106  
3565 AM Utrecht,  
The Netherlands  
Tel: +31-30-261-96-56  
Fax: +31-30-261-96-57  
E-mail: [info@datavideo.nl](mailto:info@datavideo.nl)

## Datavideo United Kingdom

Datavideo UK Limited  
Units1 & 2 Waterside Business Park  
Hadfield, Glossop, Derbyshire  
SK13 1BE, UK  
Tel: +44-1457 851 000  
Fax: +44-1457 850 964  
E-mail: [sales@datavideo.co.uk](mailto:sales@datavideo.co.uk)

## Datavideo USA

Datavideo Corporation  
7048 Elmer Avenue.  
Whittier, CA 90602,  
U.S.A.  
Tel: +1-562-696 2324  
Fax: +1-562-698 6930  
E-mail: [sales@datavideo.us](mailto:sales@datavideo.us)

## Datavideo China

Datavideo Technologies China Co  
101, NO.618, LiuYing Rd, Zhabei District,  
Shanghai, China  
Tel: +86 21-5603 6599  
Fax: +86 21-5603 6770  
E-mail: [service@datavideo.cn](mailto:service@datavideo.cn)

## Datavideo Singapore

Datavideo Technologies (S) PTE Ltd  
No. 178 Paya Lebar Road #06-03  
Singapore 409030  
Tel: +65-6749 6866  
Fax: +65-6749 3266  
E-mail: [sales@datavideo.sg](mailto:sales@datavideo.sg)

## Datavideo Hong Kong

Datavideo Hong Kong Ltd  
G/F., 26 Cross Lane  
Wanchai, Hong Kong  
Tel: +852-2833-1981  
Fax: +852-2833-9916  
E-mail: [info@datavideo.com.hk](mailto:info@datavideo.com.hk)

## Datavideo France

Datavideo France s.a.r.l  
Cité Descartes 1, rue Albert Einstein  
Champs sur Marne  
774477-Marne la Vallée cedex 2  
Tel: +33-1-60370246  
E-mail: [info@datavideo.fr](mailto:info@datavideo.fr)

## Datavideo India

Datavideo Technologies India Pvt Ltd  
A-132, Sec-63, Noida-201307,  
Uttar Pradesh (UP), India.  
Tel: +91-0120-2427337  
Fax: +91-0120-2427338  
E-mail: [sales@datavideo.in](mailto:sales@datavideo.in)



Please refer to our website for update the latest version manual.  
[www.datavideo.com/Mixer+-+Switchers/RMC-260](http://www.datavideo.com/Mixer+-+Switchers/RMC-260)

**datavideo**  
[www.datavideo.com](http://www.datavideo.com)