

# Panasonic®

## Operating Instructions

---

Memory Card Camera-Recorder

Model No. **AG-HPX610P**

Model No. **AG-HPX610EJ**

### P2HD

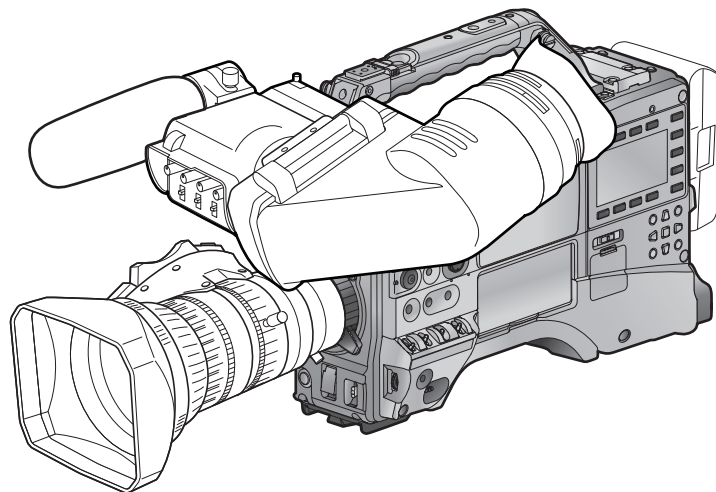

**HDMI**



**DV**

**AVC INTRA**

**DVC PRO HD**

**DVC PRO 50**

**DVC PRO**

Before operating this product, please read the instructions carefully and save this manual for future use.

## Read this first! (For AG-HPX610P/AG-HPX610EJ)



indicates safety information.

### WARNING:

- To reduce the risk of fire, do not expose this equipment to rain or moisture.
- To reduce the risk of fire, keep this equipment away from all liquids. Use and store only in locations which are not exposed to the risk of dripping or splashing liquids, and do not place any liquid containers on top of the equipment.

### WARNING:

Always keep memory cards (optional accessory) out of the reach of babies and small children.

### CAUTION:

To reduce the risk of fire and annoying interference, use the recommended accessories only.

### CAUTION:

To reduce the risk of fire, refer mounting of the optional interface boards to qualified service personnel.

### CAUTION:

Do not jar, swing, or shake the unit by its handle while the conversion lens or another accessory is attached.  
Due to the added weight of the conversion lens, any strong jolt to the handle may damage the unit or result in personal injury.

### CAUTION:

In order to maintain adequate ventilation, do not install or place this unit in a bookcase, built-in cabinet or any other confined space. To prevent risk of fire hazard due to overheating, ensure that curtains and any other materials do not obstruct the ventilation.

### CAUTION:

Do not lift the unit by its handle while the tripod is attached. When the tripod is attached, its weight will also affect the unit's handle, possibly causing the handle to break and hurting the user. To carry the unit while the tripod is attached, take hold of the tripod.

### CAUTION:

Excessive sound pressure from earphones and headphones can cause hearing loss.

### CAUTION:

Do not leave the unit in direct contact with the skin for long periods of time when in use.  
Low temperature burn injuries may be suffered if the high temperature parts of this unit are in direct contact with the skin for long periods of time.  
When using the equipment for long periods of time, make use of the tripod.

### CAUTION:

A coin type battery is installed inside of the unit.  
Do not store the unit in temperatures over 60 °C (140 °F).  
Do not leave the unit in an automobile exposed to direct sunlight for a long period of time with doors and windows closed.

Battery recycling symbol (valid only in Taiwan)

臺灣限定的廢電池回收標識。



廢電池請回收

## Read this first! (For AG-HPX610P)

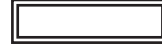

indicates safety information.

### FCC NOTICE (USA)

#### Declaration of Conformity

Model Number: AG-HPX610P  
Trade Name: Panasonic  
Responsible Party: Panasonic Corporation of North America  
Two Riverfront Plaza, Newark, NJ 07102  
Support contact: 1-800-524-1448

This device complies with Part 15 of the FCC Rules.

Operation is subject to the following two conditions:

(1) This device may not cause harmful interference, and (2) this device must accept any interference received, including interference that may cause undesired operation.

To assure continued compliance, follow the attached installation instructions and do not make any unauthorized modifications.

#### NOTE:

This equipment has been tested and found to comply with the limits for a Class B digital device, pursuant to Part 15 of the FCC Rules. These limits are designed to provide reasonable protection against harmful interference in a residential installation. This equipment generates, uses and can radiate radio frequency energy and, if not installed and used in accordance with the instructions, may cause harmful interference to radio communications. However, there is no guarantee that interference will not occur in a particular installation. If this equipment does cause harmful interference to radio or television reception, which can be determined by turning the equipment off and on, the user is encouraged to try to correct the interference by one or more of the following measures:

- Reorient or relocate the receiving antenna.
- Increase the separation between the equipment and receiver.
- Connect the equipment into an outlet on a circuit different from that to which the receiver is connected.
- Consult the dealer or an experienced radio/TV technician for help.

The user may find the booklet "Something About Interference" available from FCC local regional offices helpful.

#### Warning:

To assure continued FCC emission limit compliance, follow the attached installation instructions and the user must use only shielded interface cables when connecting to host computer or peripheral devices. Also, any unauthorized changes or modifications to this equipment could void the user's authority to operate this device.

### NOTIFICATION (Canada)

CAN ICES-3 (B)/NMB-3(B)

A rechargeable battery that is recyclable powers the product you have purchased.

## Read this first! (For AG-HPX610EJ)



indicates safety information.

### CAUTION:

Do not remove panel covers by unscrewing.  
No user serviceable parts inside. Refer servicing to qualified service personnel.

EEE Yönetmeliğine Uygundur.  
EEE Complies with Directive of Turkey.

Manufactured by: Panasonic Corporation, Osaka, Japan  
Importer's name and address of pursuant to EU rules:  
Panasonic Marketing Europe GmbH  
Panasonic Testing Centre  
Winsbergring 15, 22525 Hamburg, Germany

## EMC NOTICE FOR THE PURCHASER/USER OF THE APPARATUS

### 1. Applicable standards and operating environment

#### The apparatus is compliant with:

- standards EN55103-1 and EN55103-2, and
- electromagnetic environments E1, E2, E3 and E4.

### 2. Pre-requisite conditions to achieving compliance with the above standards

#### <1> Peripheral equipment to be connected to the apparatus and special connecting cables

- The purchaser/user is urged to use only equipment which has been recommended by us as peripheral equipment to be connected to the apparatus.
- The purchaser/user is urged to use only the connecting cables described below.

#### <2> For the connecting cables, use shielded cables which suit the intended purpose of the apparatus.

- Video signal connecting cables  
Use double shielded coaxial cables, which are designed for 75-ohm type high-frequency applications, for SDI (Serial Digital Interface).  
Coaxial cables, which are designed for 75-ohm type high-frequency applications, are recommended for analog video signals.
- Audio signal connecting cables  
If your apparatus supports AES/EBU serial digital audio signals, use cables designed for AES/EBU.  
Use shielded cables, which provide quality performance for high-frequency transmission applications, for analog audio signals.
- Other connecting cables  
Use shielded cables, which provide quality performance for high-frequency applications, such as connecting cables for IEEE1394 or USB.
- When connecting to the HDMI signal terminal, use multilayer shielded cables, which provide quality performance for high-frequency applications.
- When connecting to the DVI signal terminal, use a cable with a ferrite core.
- If your apparatus is supplied with ferrite core(s), they must be attached on cable(s) following instructions in this manual.

### 3. Performance level

The performance level of the apparatus is equivalent to or better than the performance level required by these standards.

However, the apparatus may be adversely affected by interference if it is being used in an EMC environment, such as an area where strong electromagnetic fields are generated (by the presence of signal transmission towers, cellular phones, etc.). In order to minimize the adverse effects of the interference on the apparatus in cases like this, it is recommended that the following steps be taken with the apparatus being affected and with its operating environment:

1. Place the apparatus at a distance from the source of the interference.
2. Change the direction of the apparatus.
3. Change the connection method used for the apparatus.
4. Connect the apparatus to another power outlet where the power is not shared by any other appliances.

Декларація про Відповідність  
Вимогам Технічного Регламенту Обмеження Використання деяких Небезпечних Речовин в  
електричному та електронному обладнанні  
(затвердженого Постановою №1057 Кабінету Міністрів України)

Виріб відповідає вимогам Технічного Регламенту Обмеження Використання деяких Небезпечних Речовин в електричному та електронному обладнанні (ТР ОВНР).

Вміст небезпечних речовин у випадках, не обумовлених в Додатку №2 ТР ОВНР, :

1. свинець(Pb) – не перевищує 0,1 % ваги речовини або в концентрації до 1000 частин на мільйон;
2. кадмій (Cd) – не перевищує 0,01 % ваги речовини або в концентрації до 100 частин на мільйон;
3. ртуть(Hg) – не перевищує 0,1 % ваги речовини або в концентрації до 1000 частин на мільйон;
4. шестивалентний хром (Cr<sup>6+</sup>) – не перевищує 0,1 % ваги речовини або в концентрації до 1000 частин на мільйон;
5. полібромбіфеноли (PBВ) – не перевищує 0,1 % ваги речовини або в концентрації до 1000 частин на мільйон;
6. полібромдефенілові ефіри (PBDE) – не перевищує 0,1 % ваги речовини або в концентрації до 1000 частин на мільйон.



## TO REMOVE BATTERY

### Main Power Battery (Ni-Cd / Ni-MH / Li-ion Battery)

- To detach the battery, please proceed in the reverse order of the installation method described in this manual.
- If a battery made by any other manufacturer is to be used, check the Operating Instructions accompanying the battery.

### Back-up Battery (Lithium Battery)

- For the removal of the battery for disposal at the end of its service life, please consult your dealer.

- 
- The SDHC logo is a trademark of SD-3C, LLC.
  - HDMI, HDMI logo, and High-Definition Multimedia Interface are trademarks or registered trademarks of HDMI Licensing LLC in the United States and/or other countries.
  - MMC (Multi Media Card) is a registered trademark of Infineon Technologies AG.
  - Microsoft and Windows are trademarks or registered trademarks of Microsoft Corporation in the United States and/or other countries.
  - Screenshots are used according to Microsoft Corporation guidelines.
  - Apple, Macintosh, Mac OS, and QuickTime are trademarks or registered trademarks of Apple Inc. in the United States and/or other countries.
  - UniSlot is a registered trademark of Ikegami Tsushinki Co., LTD.
  - All other names, company names, product names, etc., contained in this instruction manual are trademarks or registered trademarks of their respective owners.
  - This product is licensed under the AVC Patent Portfolio License. All other acts are not licensed except private use for personal and non-profit purposes such as what are described below.
    - To record video in compliance with the AVC standard (AVC Video)
    - To play back AVC Video that was recorded by a consumer engaged in a personal and non-commercial activity
    - To play back AVC Video that was obtained from a video provider licensed to provide the videoVisit the MPEG LA, LLC website (<http://www.mpegla.com/>) for details.
  - Use of DCF Technologies under license from Multi-Format, Inc.

## **How to read this document**

---

### **■ Illustrations**

- Illustrations of the camera, menu screens, and other items, may vary from the actual items.

### **■ Reference pages**

- Reference pages in this document are indicated by (page 00).

### **■ Terminology**

- Both SD memory card and SDHC memory card are referred to as SD memory card.
- Memory card that has the "P2" logo (such as optional AJ-P2E064FG) is referred to as "P2 card".
- Memory card that has the "microP2" logo (such as optional AJ-P2M032AG) is referred to as "microP2 card". To use, insert it into the microP2 card adaptor AJ-P2AD1G (optional).
- P2 memory card and microP2 memory card are referred to only as "P2 card" unless distinguished otherwise.
- Video that is created during a single recording operation is referred to as a "clip".

# Contents

|   |           |   |            |
|---|-----------|---|------------|
| Read this first! (For AG-HPX610P/AG-HPX610EJ) .....                       | 2         | <b>Selecting audio input and adjusting recording levels</b> .....                                       | 60         |
| Read this first! (For AG-HPX610P) .....                                   | 3         | Selecting audio input signals .....   | 60         |
| Read this first! (For AG-HPX610EJ) .....                                  | 4         | Adjusting the recording levels .....  | 60         |
|   |           | Selecting <F.AUDIO LEVEL> dial function .....   | 60         |
| <b>Chapter 1 Overview</b> .....   | <b>9</b>  | <b>Setting the time data</b> .....  | <b>61</b>  |
| Before using the camera .....   | 10        | Recording and output of time codes and user bits .....  | 61         |
| Main features .....   | 11        | User bits settings .....  | 64         |
| Features of the camera unit .....   | 12        | How to input user bits .....  | 64         |
| Features of recorder/playback unit .....                                  | 13        | Setting the time code .....   | 66         |
| How to use the camera .....   | 15        | Externally locking the time code .....  | 67         |
| Editing, saving using external equipment .....                            | 15        | Supplying time codes to external devices .....  | 68         |
| System configuration .....  | 16        | Connecting and setting the generator lock and time code<br>input/output .....                           | 69         |
| Accessories .....   | 18        | Counter setting and display .....   | 69         |
| <b>Chapter 2 Description of Parts</b> .....                               | <b>19</b> | <b>Viewfinder status display</b> .....  | <b>70</b>  |
| Power supply and accessory mounting section .....                         | 20        | Lamp display in the viewfinder .....  | 70         |
| Audio (input) function section .....                                      | 21        | Mode check screen displays (mode check function) .....  | 70         |
| Audio (output) function section .....                                     | 22        | Configuration of status display on viewfinder screen .....  | 71         |
| Shooting and recording/playback functions section .....                   | 23        | Selecting display items on viewfinder screen .....  | 71         |
| Menu operation section and thumbnail operation section .....              | 26        | Screen display .....  | 71         |
| Time code section .....   | 27        | Information display in center .....   | 75         |
| Warning and status display section .....                                  | 28        | Checking and displaying shooting status .....   | 76         |
| SmartUI display ([HOME] screen) .....                                     | 29        | Mode check display .....  | 78         |
| <b>Chapter 3 Recording and Playback</b> .....                             | <b>30</b> | Center marker display .....   | 79         |
| Setting the date/time of the internal clock .....                         | 31        | Safety zone display .....   | 79         |
| P2 card .....   | 32        | Zebra patterns display .....  | 80         |
| Inserting a P2 card .....   | 32        | Focus assist function .....   | 80         |
| Removing a P2 card .....  | 32        | Waveform monitor function .....   | 81         |
| Preventing accidental erasure .....                                       | 33        | <b>Handling setting data</b> .....  | <b>82</b>  |
| P2 card access LEDs and status of P2 cards .....                          | 33        | Setting data file configuration .....   | 82         |
| P2 card recording time .....  | 33        | Handling SD memory cards .....  | 82         |
| How to handle data recorded on P2 cards .....                             | 34        | Performing operations on SD memory cards .....  | 83         |
| Basic procedures .....  | 35        | How to use scene file data .....  | 84         |
| For shooting .....  | 35        | Saving scene files, etc. to SD memory cards .....   | 85         |
| Standard recording .....  | 36        | <b>Chapter 5 Preparation</b> .....  | <b>87</b>  |
| Standard recording and native recording .....                             | 37        | Power supply .....  | 88         |
| Standard recording (Pull-down recording) .....                            | 37        | Mounting and setting battery .....  | 88         |
| Native recording .....  | 37        | Using external DC power supply .....  | 89         |
| Variable frame rate (VFR) recording function (extra-cost<br>option) ..... | 38        | <b>Mounting and adjusting the lens</b> .....  | <b>91</b>  |
| Native variable frame rate recording .....                                | 38        | Mounting the lens .....   | 91         |
| Standard variable frame rate recording (pull-down recording) .....        | 38        | Flange back adjustment .....  | 91         |
| Using the variable frame rate recording function .....                    | 38        | White shading compensation .....  | 92         |
| Special recording functions .....   | 41        | Chromatic aberration compensation function (CAC) .....  | 93         |
| Pre-recording .....   | 41        | <b>Preparing for audio input</b> .....  | <b>96</b>  |
| Interval recording .....  | 41        | Using the front microphone .....  | 96         |
| One-shot recording .....  | 42        | Using a wireless receiver .....   | 96         |
| Loop recording .....  | 42        | Using audio devices .....   | 96         |
| One-clip recording .....  | 43        | <b>Mounting accessories</b> .....   | <b>97</b>  |
| Proxy recording function (extra-cost option) .....                        | 44        | Mounting the camera on a tripod .....   | 97         |
| Hot swap recording .....  | 44        | Attaching the shoulder strap .....  | 97         |
| Rec review function .....   | 44        | Attaching the rain cover .....  | 98         |
| Shot mark recording function .....  | 44        | <b>Connecting the &lt;DC OUT&gt; terminal with the external<br/>  recording start/stop switch</b> ..... | <b>99</b>  |
| Text memo recording function .....  | 45        | <b>Chapter 6 Thumbnail Operations for Clips</b> .....   | <b>100</b> |
| Normal and variable speed playback .....                                  | 46        | <b>Thumbnail operations</b> .....   | <b>101</b> |
| <b>Chapter 4 Adjustments and Settings for<br/>  Recording</b> .....       | <b>47</b> | Thumbnail operation overview .....  | 101        |
| Multi formats .....   | 48        | Thumbnail screen .....  | 102        |
| Selecting recording signals .....   | 48        | Selecting thumbnails .....  | 103        |
| Recording formats and recording playback times .....                      | 48        | Playing back clips .....  | 104        |
| List of recording settings and recording functions .....                  | 48        | Switching the thumbnail display .....   | 104        |
| Selecting video output .....  | 49        | Changing thumbnails .....   | 104        |
| List of recording/playback and output formats .....                       | 49        | Shot mark .....   | 105        |
| Adjusting the white and black balance .....                               | 53        | Text memo .....   | 105        |
| Adjusting the white balance .....   | 53        | Deleting clips .....  | 107        |
| Adjusting the black balance .....   | 55        | Restoring clips .....   | 107        |
| Setting the electronic shutter .....                                      | 56        | Reconnecting incomplete clips .....   | 107        |
| Setting the shutter mode and speed .....                                  | 56        | Copying clips .....   | 108        |
| Setting the synchro scan mode .....                                       | 56        | Setting clip metadata .....   | 108        |
| Flash band compensation (FBC) function .....                              | 58        | Formatting a P2 card .....  | 111        |
| Setting the flash band compensation function .....                        | 58        | Formatting SD memory cards .....  | 111        |
| Assigning functions to <USER> buttons .....                               | 59        | Setting the thumbnail display .....   | 111        |
|   |           | Properties .....  | 112        |
|   |           | <b>Chapter 7 Menu Operations</b> .....  | <b>115</b> |
|   |           | Displaying the setting menu on the viewfinder screen .....  | 116        |

|   |            |
|---|------------|
| Setting menu basic operations .....   | 116        |
| Menu direct close function .....  | 117        |
| Changing setting values quickly (only for [MASTER PED] and [H PHASE]) .....   | 117        |
| Initializing the setting menu items .....                                     | 117        |
| <b>Setting menu structure .....</b>   | <b>118</b> |
| <b>Menu list .....</b>  | <b>120</b> |
| [SCENE FILE] screen .....   | 120        |
| [SYSTEM SETUP] screen .....   | 122        |
| [SW MODE] screen .....  | 123        |
| [RECORDING SETUP] screen .....  | 124        |
| [AUDIO SETUP] screen .....  | 125        |
| [IN/OUT SEL] screen .....   | 127        |
| [DISPLAY SETUP] screen .....  | 127        |
| [BATTERY SETUP] screen .....  | 128        |
| [CARD FUNCTIONS] screen .....   | 130        |
| [LENS SETUP] screen .....   | 130        |
| [PROXY SETTING] screen .....  | 131        |
| [PC/USB/LAN] screen .....   | 131        |
| [OTHER FUNCTIONS] screen .....  | 132        |
| [DIAGNOSTIC] screen .....   | 133        |
| <br>  |            |
| <b>Chapter 8 Using SmartUI .....</b>  | <b>134</b> |
| <b>Setting menu basic operations .....</b>                                    | <b>135</b> |
| SmartUI basic operations .....  | 135        |
| Initializing SmartUI setting menu items .....                                 | 135        |
| <b>Setting menu structure .....</b>   | <b>136</b> |
| <b>SmartUI menu operation overview .....</b>                                  | <b>137</b> |
| <b>Menu list .....</b>  | <b>138</b> |
| [CAMERA] screen .....   | 138        |
| [AUDIO] screen .....  | 140        |
| [SETUP] screen .....  | 142        |
| [TEXT MEMO] screen .....  | 144        |
| <br>  |            |
| <b>Chapter 9 Connecting to External Devices .....</b>                         | <b>145</b> |
| <b>Connection through the &lt;USB2.0&gt; terminal .....</b>                   | <b>146</b> |
| USB connection to a computer in the device mode .....                         | 146        |
| USB host mode .....   | 146        |
| <b>Connecting to the remote control unit (AJ-RC10G) .....</b>                 | <b>151</b> |
| <b>Connecting to the extension control unit (AG-EC4G) .....</b>               | <b>152</b> |
| <br>  |            |
| <b>Chapter 10 Maintenance and Inspection .....</b>                            | <b>153</b> |
| <b>Inspections before shooting .....</b>                                      | <b>154</b> |
| Preparing to inspect .....  | 154        |
| Inspecting the camera unit .....  | 154        |
| Inspecting the memory recording functions .....                               | 154        |
| <b>Maintenance .....</b>  | <b>156</b> |
| Charging the built-in battery .....   | 156        |
| <b>Warning system .....</b>   | <b>157</b> |
| Warnings description list .....   | 157        |
| Error code .....  | 158        |
| Card warning code .....   | 158        |
| Warning/error displays in the thumbnail operation and the USB host mode ..... | 158        |
| <b>Updating the camera firmware .....</b>                                     | <b>160</b> |
| <br>  |            |
| <b>Chapter 11 Additional Functions from the Optional Board .....</b>          | <b>161</b> |
| <b>Video encoder board (AG-YDX600G) .....</b>                                 | <b>162</b> |
| Proxy settings .....  | 162        |
| Recording the proxy data .....  | 163        |
| Recording to the SD memory card .....   | 163        |
| Checking the proxy data .....   | 164        |
| Error displays about proxy data recordings .....                              | 165        |
| <b>HD/SD SDI input board (AG-YA600G) .....</b>                                | <b>167</b> |
| <br>  |            |
| <b>Chapter 12 Specification .....</b>   | <b>168</b> |
| <b>Dimensions and specifications .....</b>                                    | <b>169</b> |
| Dimensions .....  | 169        |
| Specifications .....  | 169        |
| <b>Details of the connector signals .....</b>                                 | <b>173</b> |
| <b>Index .....</b>  | <b>176</b> |



# Chapter 1 **Overview**

---

Before using the camera, read this chapter, and check its features and accessories. Function extensions as extra-cost options are also explained.

## Before using the camera

---

### ■ Caution regarding laser beams

The MOS sensor may be damaged if the MOS sensor is subjected to light from a laser beam. Make sure that laser beams do not strike the lens when shooting in an environment where laser devices are used.

### ■ Note the following points.

- When preparing to record important images, always shoot some advance test footage to verify that both pictures and sound are being recorded normally.
- Should video or audio recording fail due to a malfunction of the camera or the P2 cards used, we will not assume liability for such failure.

### ■ What to remember when throwing memory cards away or transferring them to others

Formatting memory cards or deleting data using the functions of the camera or a computer will merely change the file management information: it will not completely erase the data on the cards. When throwing these cards away or transferring them to others, either physically destroy them or use a data deletion program for computers (commercially available) to completely erase the data. Users are responsible for managing the data stored in their memory cards.

### ■ Software information about this product

- 1 This product includes software licensed under GNU General Public License (GPL) and GNU Lesser General Public License (LGPL), and customers are hereby notified that they have rights to obtain, re-engineer and redistribute the source code of these software.
- 2 This product includes software licensed under MIT-License.
- 3 This product includes software developed by the OpenSSL Project for use in the OpenSSL Toolkit (<http://www.openssl.org/>).
- 4 This product includes software licensed under OpenBSD License.
- 5 This product includes PHP, freely available from <http://www.php.net/>.
- 6 This software is based in part on the work of the Independent JPEG Group.
- 7 This product includes software licensed under MOZILLA PUBLIC LICENSE.

For details (which are originally provided in English) and how to obtain the source code, visit the following website.  
<http://pro-av.panasonic.net/>

We do not accept inquiries about the details of the source code obtained by the customer.

### ■ Precautions when installing USB drivers

For the latest information on the driver, visit the following website.

<http://pro-av.panasonic.net/>

- Install the required driver into your computer from the website.
- For installation procedure of the driver, refer to the installation manual on the website.

## Main features

The P2 memory card camera-recorder AG-HPX610P/AG-HPX610EJ incorporates the MOS sensor newly developed for the camera unit to ensure that high-sensitivity F12 (59.94 Hz), high-resolution, and high-quality video can be obtained. The camera also uses a 2/3-inch lens mount to accommodate many existing interchangeable lenses and features a compact body to provide amazing action for a body weight of approximately 2.8 kg.

The camera supports 50 Hz/59.94 Hz switchable and HD/SD multi-format. The AVC-Intra, DVCPRO HD, DVCPRO50, DVCPRO, and DV compression recording formats can be selected, and the reliability, instantaneousness and IT functions expected of P2 helps revolutionize work flow.

An add-on system for optional functions (extra-cost options) is also available for selecting and installing only required functions.

### ■ Function extension (extra-cost options)

As of start of sales, the following functions (extra-cost options) are available:

- Video encoder board AG-YDX600G  
This enables proxy recording. This is effective in checking and editing clips.
- HD/SD SDI input board AG-YA600G  
This enables recording of the SDI signal input from the <SDI OUT/IN (OP)> terminal.
- Upgrade Software Key AG-SFU601G (Network function)  
This enables addition of text memos from IT devices.  
In explanations from here on, this option is referred to as “network function (extra-cost option)”.
- Upgrade Software Key AG-SFU602G (Production pack)  
This allows the following functions to be used to achieve substantial video production functions:
  - 1080/23.98PsF system
  - Variable frame rate (VFR) recording function
 In explanations from here on, this option is referred to simply as “production pack (extra-cost option)”.
- Upgrade Software Key AG-SFU603G (UPLINK device control function)  
This enables starting and stopping UPLINK device data transfer, displaying the connection status icon, and displaying detailed information about the device.  
In explanations from here on, this option is referred to as “UPLINK device control function (extra-cost option)”.
- Upgrade Software Key AG-SFU604G (Playlist edit function)  
This is a function that edits the playlist by using proxy video.  
This enables editing/saving the playlist, creating a new clip by using a playlist (edit copy), and SDI playback of the playlist.  
In explanations from here on, this option is referred to as “Playlist edit function (extra-cost option)”.

### ■ 50 Hz/59.94 Hz switchable and HD/SD multi-format

Recording by the HD/SD video format is supported. 50 Hz/59.94 Hz switchable accommodates all kinds of applications and global content production in addition to news reporting and program/video production. For 1080i/720P HD recording, the highly reliable AVC-Intra/DVCPRO HD codecs can be selected for broadcasting use, and for SD video, the DVCPRO50/DVCPRO/DV multi-codecs can be selected.

4-channel recording (all formats) is provided for 16-bit/48 kHz non-compressed high-quality audio.

### ■ SmartUI

New operability is provided by integrating the conventional LCD window and audio selector switches. Remote control from IT devices and other functionality ensure expandability for future applications.

## Features of the camera unit

### ■ Progressive 2/3-inch MOS sensor

It incorporates a newly developed 2/3-inch MOS sensor to ensure high-sensitivity and high-resolution video.

### ■ 14-bit digital circuit

The camera has in-built high performance DSP (digital signal processor) for processing 14-bit signal input and 20-bit internal computations. This circuit sets gamma and other corrections for each R/G/B color of 1080/60P video, and batch processes up to conversion (P/I conversion, line conversion, down conversion) to various HD/SD formats. This ensures high-resolution video output in any video format.

### ■ Seven gamma curve modes including cine-like gamma

You can select from seven gamma curve modes, including cine-like gamma for easily reproducing film-like tones, for greater breadth in video production.

### ■ Slow/synchro/high-speed shutter

The shutter speed can be selected at will from the slowest speed of 1/12 seconds up to the highest speed of 1/7200 seconds\*. The synchro scan function suited to recording on monitor screens can also be provided.

\* The above is the shutter value when the [SYNCHRO SCAN] item on the [SCENE FILE] screen is set to [3d].

### ■ Shooting assist function

#### ● <USER> buttons (<USER MAIN>/<USER1>/<USER2>):

Frequently used functions can be assigned to the three <USER> buttons (<USER MAIN>/<USER1>/<USER2>) and executed by simply pressing the required button.

#### ● Focus assist:

Enlarging the the center part of the screen and displaying the focus bar assist focusing.

#### ● Eight lens chromatic aberration files/four shading compensation files that are compatible with replacement lenses provided

#### ● Color temperature conversion:

Color-temperature can be fine-adjusted after the white balance is set.

#### ● Rec review function:

The last several seconds of the previously recorded clip can be quickly checked.

#### ● Equipped with optical ND filters at four positions

### ■ Chromatic aberration compensation function (CAC)

The camera is equipped with a function to automatically correct registration error that occurs mainly due to slight chromatic aberration, etc., which cannot be compensated on the lens itself, and minimizes color smearing in peripheral images.

### ■ Remote control supported

The remote control unit (optional/AJ-RC10G) and extension control unit (optional/AG-EC4G) are supported. You can control the camera, such as adjusting the camera image or performing recording operations, remotely while monitoring the camera image.

### ■ Auto tracking white balance (ATW) function

The white balance is automatically adjusted according to the subject in real time. This feature is effective when you have no margin for adjusting white balance manually, for example, when recording in an emergency.

### ■ Dynamic range stretcher (DRS) function

With this function, the video signal level of high brightness areas that may be skipped with white blanks in regular recording methods can be expanded by compressing images and maintaining the contrast.\*

\* The dynamic range stretcher function does not work in the 1080/24P, 1080/30P, and 1080/25P modes.

### ■ Camera extension system

By combining the optional camera adaptor (AG-CA300G) and base station (AG-BS300), you can operate the camera as a camera extension system. For connections with these devices, refer to the connection methods and precautions described in the instruction manual of each device.

The camera only supports the HD viewfinder. To display return video images on the viewfinder screen with the system where the optional VF interface box (AG-YA500G) is connected, set the [SYSTEM MODE] item to [1080-59.94i] or [1080-50i]. The [SYSTEM MODE] item can be selected from the setting menu [SYSTEM SETUP] screen.

### ■ Viewfinder connection

1080/59.94i or 1080/50i signals are output from the viewfinder connector of the camera.

By connecting the optional view finder (AG-CVF10G, AJ-HVF21KG, AJ-CVF100G), images compatible with multi-format can be viewed.

## Features of recorder/play unit

### ■ Various interfaces

#### ● <USB2.0> terminal (host/device) provided

By connecting to a computer via USB 2.0, the P2 card inserted on the camera can be used as mass storage.

The camera also incorporates the USB host function, allowing data on the P2 card to be saved on the hard disk drive connected with USB 2.0 or clips saved on the hard disk drive to be viewed or written back to the P2 card.

#### ● <LAN> terminal provided

By installing the network function (extra-cost option), metadata can be input from a computer.

### ■ Large-capacity, high-speed transfer, highly reliable P2 card

P2 cards are semiconductor memory that is highly resistant to impact, vibration and temperature changes, and are highly reliable since they have no parts that rotate or contact other parts when recording or playing back, like on tape or disk, which enables these cards to be repeatedly used for recording and initialized over a prolonged period of time. Connectors have also been designed for professional use to ensure greater durability when cards are removed or inserted.

Recorded A/V data is recorded to P2 cards as files for individual cuts that do not require digitizing, which means that they are ready for nonlinear editing or transfer over a network. Optical disks can be worked on at ease at an amazing transfer speed. The PC card standard is also supported, which means that PC cards can be plugged in directly to the PC card slot on your computer.\*1

The unit is equipped with two P2 card slots, enabling continuous recordings for two P2 cards, and they also provide the following recording capabilities specific to memory card recorders:

#### ● Card selection:

The recording slot can be selected (switched) in a standby state\*2. When recording material is forwarded immediately after it is recorded for editing or transmission, recording can be continued by an interruption far shorter than by tape or disk replacement.

#### ● Hot swap recording:

Cards can be replaced even during recording. This capability allows continuous recording without any interruption since recorded cards can be successively swapped while recording is continued on another card slot.

#### ● Loop recording:

The unit can retain a certain amount of previously recorded material at all times by successively loop recording data into a specified recording area.

\*1 The P2 card driver must be installed. For details on the operating environment required for the P2 card driver, visit the support desk at the following website:  
<http://pro-av.panasonic.net/>

\*2 Set the [SLOT SEL] function to the <USER> buttons (<USER MAIN>/<USER1>/<USER2>).

### ■ Instant start and secure data protection

Recording is started instantaneously from a standby state. Since recording is automatically performed to free space on the card, there is no need to cue up blank area as you do for VTRs. Recording can be started immediately even during a preview simply by pressing the <REC> button. In the Normal mode, recorded data is never lost by it being overwritten. So, you can be rest assured that your data is safe unless files are deleted or the card is initialized.

### ■ Other features

#### ● Pre-recording:

Critical moments that you might have missed can be recovered. In a standby state, approximately three seconds and approximately seven seconds of video and audio input to the camera is stored in memory in the HD and SD modes, respectively. This means that video and audio are recorded for several seconds preceding pressing of the <REC> button.

#### ● One-shot recording:

This function records for the preset time (single frame to one second) at each press of the <REC> button and is handy for producing animations.

#### ● Interval recording:

In this mode, single frames are recorded at a preset interval (two frames to ten minutes). This allows monitoring and observation, and special effects to be obtained by ultra-undercrank shooting.

#### ● One-clip recording:

This function allows multiple recordings into a combined clip and does not isolate single recording (from recording start to stop). The combined clip can be handled with ease in transferring or copying, etc. as the clip can be handled as a single thumbnail or as a single clip in editing. Up to 99 recordings can be combined into a single clip.

#### ● Proxy recording (extra-cost option):

By installing the video encoder board (extra-cost option), video recordings in MPEG4 format or H.264 format and real-time metadata such as time code data can be recorded to the P2 card and SD memory card simultaneously, in addition to the video and audio of the materials recorded on the camera. This is effective in checking and editing clips.

### ■ Clip thumbnail preview

Recordings are made as clips (files) for each cut. A thumbnail image and file information are automatically appended to each clip. When previewing on the viewfinder screen, the clip selected from the thumbnail list display can immediately be played back or the clip data can be checked. This thumbnail and file information is also displayed on a computer (by P2 Viewer Plus\*) or in nonlinear editing software.

\* P2 Viewer Plus is viewing software for Windows PCs provided to P2 users by free download.

### ■ Shot marks and text memo

Shot marks which, for example, can help you distinguish OK cuts from reject cuts, are assigned to each clip. Shot marks can be added both during and after a recording. Only marked clips can be displayed when clips are mounted on a computer (by P2 Viewer Plus).

A function for recording text memos is also provided so that empty tag-like text memos can be registered by pressing the <USER> buttons (<USER MAIN>/<USER1>/<USER2>) assigned with this function at any locations (up to 100) in a clip during recording or preview. Memos can be searched for later on a computer (P2 Viewer Plus) to write text to.

In addition, by copying clips by text memo block, only the necessary portions can be extracted from a single clip with the camera.

### ■ SD memory card slot

The camera is provided with the SD memory card slot. Scene files and user setting files can be saved and loaded. Metadata upload files (created on P2 Viewer Plus) containing the name of the camera person or reporter, shooting location, text memos or other information can be read to the SD memory card or read as clip metadata.

### ■ HD/SD SDI output and down converter

Video output lines (BNC x2) are provided as standard. This enables flexible support of monitor or line recording. A built-in down converter is also provided to allow the aspect mode to be selected. Composite output is also supported.

### ■ HDMI output

Video can be output to a monitor compatible with the <HDMI> terminal.

- The camera is not compatible with VIERA Link.

### ■ HD/SD SDI input (extra-cost option):

By installing the HD/SD SDI input board (extra-cost option), SDI signals input from the <SDI OUT/IN (OP)> terminal can be recorded.

Note, however, that only SDI signals in the same recording format as the camera can be recorded.

### ■ Control for fine-adjustment of audio recording level

A control for fine-adjusting the audio recording level is provided on the front of the camera. This is particularly useful for adjusting the audio level when you are taking photos alone. This control can also be disabled.

### ■ Support for built-in UniSlot wireless receiver

The camera is designed to support an optional slot-in wireless receiver. (page 96)

It also supports 2-channel wireless receivers.

## How to use the camera

The camera records to P2 cards. These large-capacity P2 cards feature outstanding transfer speeds to enable HD recording, smooth editing and dubbing.

### Editing, saving using external equipment

#### Via the <USB2.0> terminal Connection to external equipment in USB device mode

Data (files) for performing nonlinear editing on a computer are transferred.

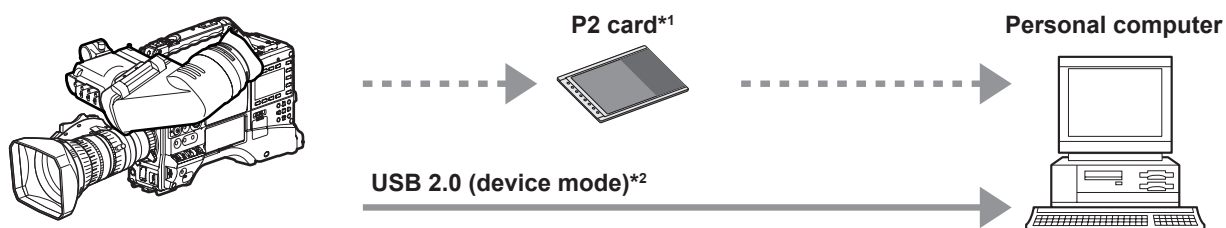

#### Via the <USB2.0> terminal Connection to external equipment in USB host mode

The camera directly controls the hard disk drive to transfer data.

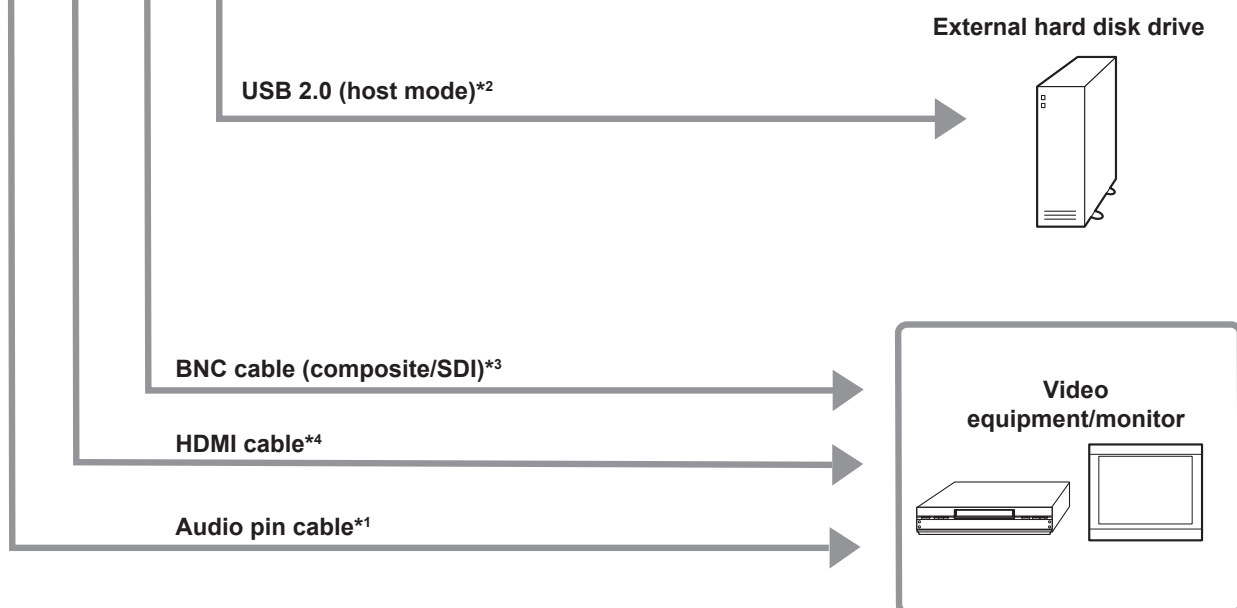

\*1 P2 cards and cables are optionally available. They are not supplied with the camera.

\*2 The USB 2.0 cable is not supplied with the camera. Prepare a commercial USB 2.0 cable (double-shielded for noise suppression).

\*3 For the BNC cable (optional) connected to the <SDI OUT/IN (OP)> and <MON OUT> terminals, prepare a double-shielded cable equivalent to 5C-FB.

\*4 Prepare the HDMI cable (optional) with double or more shielded. For the HDMI cable, use of the Panasonic HDMI cable is recommended.

## System configuration

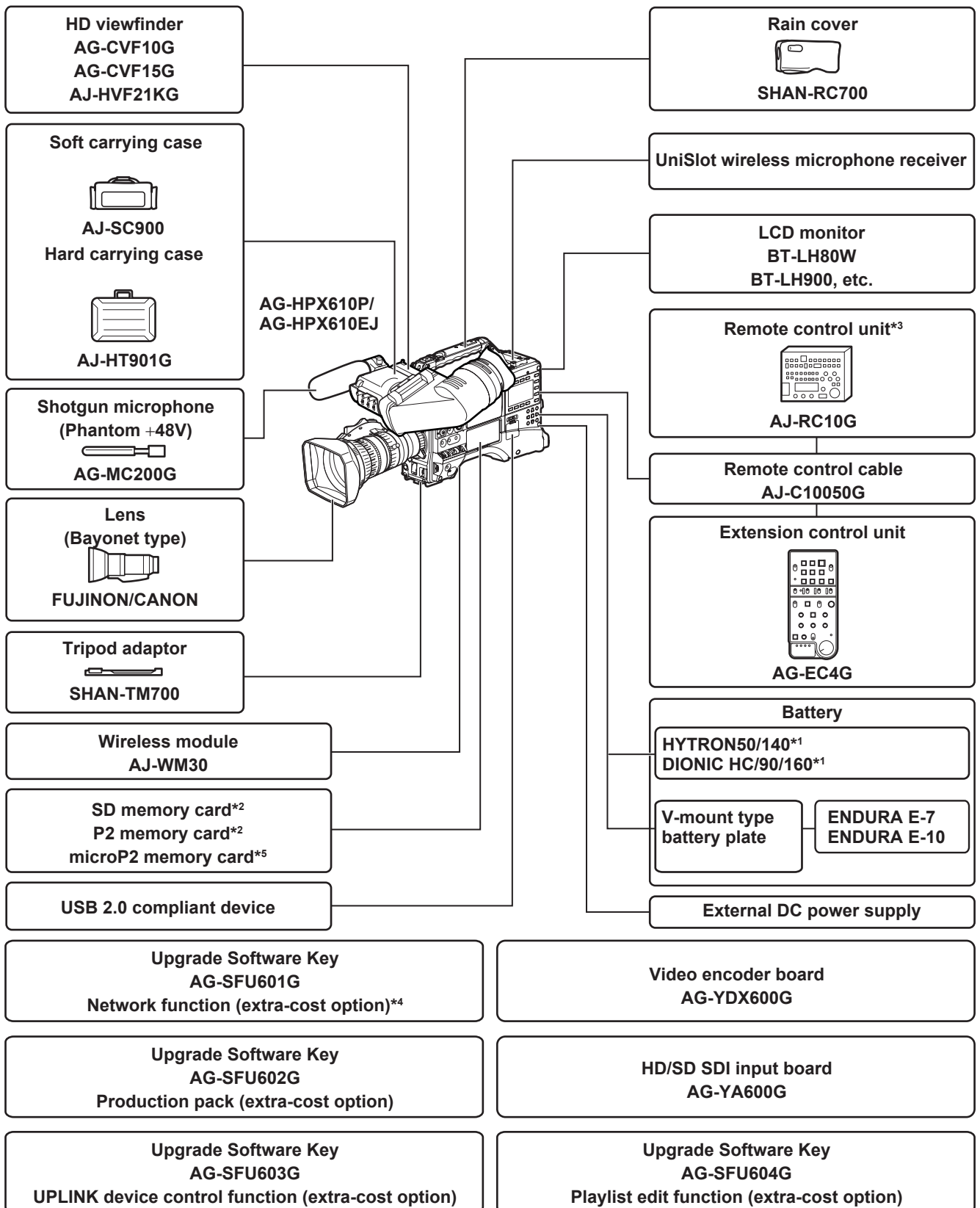



- \*1 A battery holder is provided as standard on the main unit.
- \*2 For the latest information on P2 cards and SD memory cards not available in the Operating Instructions, visit the support desk at the following website:  
<http://pro-av.panasonic.net/>
- \*3 Refer to the operating guide of "AJ-RC10G for AG-HPX600/610 series (AG-HPX600P/HPX610P/HPX600EJ/HPX610EJ/HPX600EN)" at the following website:  
<http://pro-av.panasonic.net/en/manual/index.html>
- \*4 To use the wireless LAN function for the network function, the wireless module AJ-WM30 is required. To use the streaming function of the network function, the video encoder board AG-YDX600G is required.
- \*5 To use, insert it into the microP2 card adaptor AJ-P2AD1G (optional). For details, refer to the operating instructions of "microP2 Card Compatible" at the following website: Descriptions for AG-HPX600P/AG-HPX600EJ/AG-HPX600EN in the operating instructions are also applied to AG-HPX610P/AG-HPX610EJ.  
<http://pro-av.panasonic.net/en/manual/index.html>

## Accessories

---

Shoulder strap (page 97)

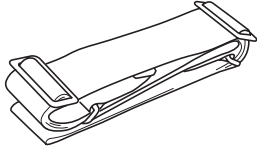

Mount cap (already attached to the product) (page 20)



 **NOTE**

---

- After unpacking the product, dispose of the packing material properly.

## Chapter 2 **Description of Parts**

---

This chapter describes the names, functions, and operations of parts on the camera. Details displayed on the [HOME] screen of SmartUI are also described.

## Power supply and accessory mounting section

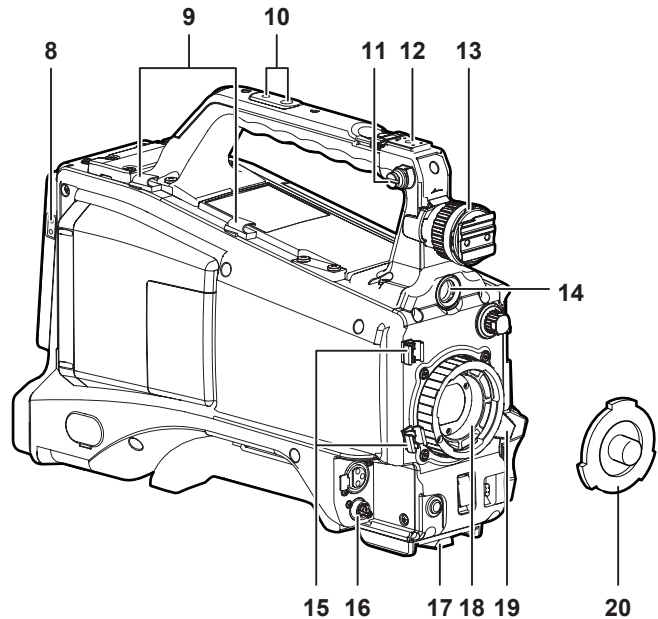
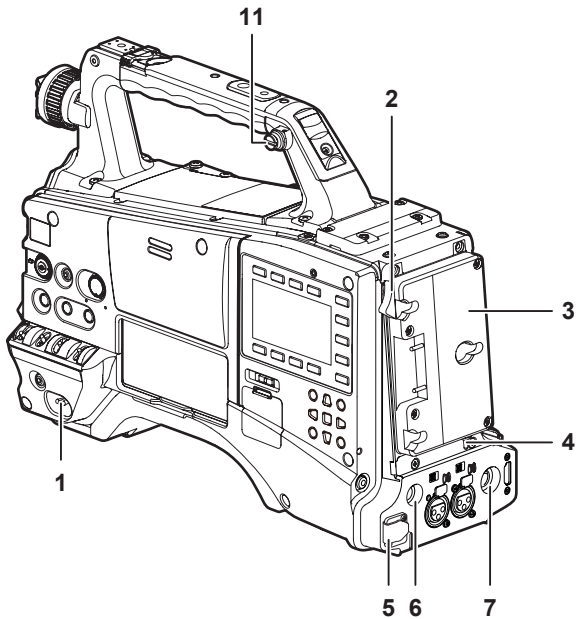

**1 <POWER> switch (page 35)**

Used to turn on/off the power.

**2 Battery release lever (page 88)**

Pull this battery release lever down to release the battery.

**3 Battery holder (page 88)**

Mount the Anton/Bauer battery.

**4 Light control switch (page 88)**

**5 <DC IN> terminal (page 89)**

This is the input terminal for the external power supply. Connect to the external DC power supply.

**6 <DC OUT> (DC power supply) output terminal (page 99)**

This is the DC 12 V output terminal. It provides a maximum current of 1.5 A.

**NOTE**

• When connecting external equipment to this terminal, first fully check the polarities of the connection. Failure to do so may result in a malfunction.

**7 <REMOTE> terminal (page 152) (page 151)**

Connect the remote control unit AJ-RC10G (optional) to remote-control some functions.

Connect the extension control unit AG-EC4G (optional) to remote-control some functions.

**8 Light output terminal**

Connect the Anton/Bauer Ultralight 2 (optional) or an equivalent product of 50 W or under for the video light. The battery charge level drops sharply when the light is illuminated. When using the light, using a battery of 90 Wh or more is recommended.

**9 Cable holders**

Used for clamping the light and microphone cables in place.

**10 Accessory mounting holes**

Attach accessories. Do not use for purposes other than attaching accessories.

- Mounting hole size
  - 1/4-20 UNC (screw length 10 mm or shorter)
  - 3/8-16 UNC (screw length 10 mm or shorter)

**11 Shoulder strap fittings (page 97)**

Attach the shoulder strap.

**12 Light shoe**

Attach the video light.

- Mounting hole size
  - 1/4-20 UNC (screw length 6 mm or shorter)

**13 Viewfinder left/right positioning ring**

To adjust the left/right position of the viewfinder, loosen this ring, and slide the viewfinder to the left or right to adjust it to an easy-to-view position. Tighten the ring to clamp the viewfinder in place after adjusting the viewfinder.

**14 <VF> terminal**

Mount the viewfinder AG-CVF10G (optional).

**15 Lens cable/microphone cable clamp (page 91)**

This clamp secures the lens and microphone cables.

**16 <LENS> terminal (page 91)**

Connect the lens connection cable. For a detailed description of the lens used, refer to the Operating Instructions for the lens.

**17 Tripod mount (page 97)**

Attach the optional tripod adaptor (SHAN-TM700) when mounting the camera on the tripod.

**18 Lens mount (2/3-type bayonet) (page 91)**

Mount the lens.

**19 Lens lever (page 91)**

After mounting the lens to the lens mount, tighten the lever to secure the lens.

**20 Mount cap (page 91)**

Raise the lens lever to remove the cap. Replace the cap when the lens is not mounted.

## Audio (input) function section

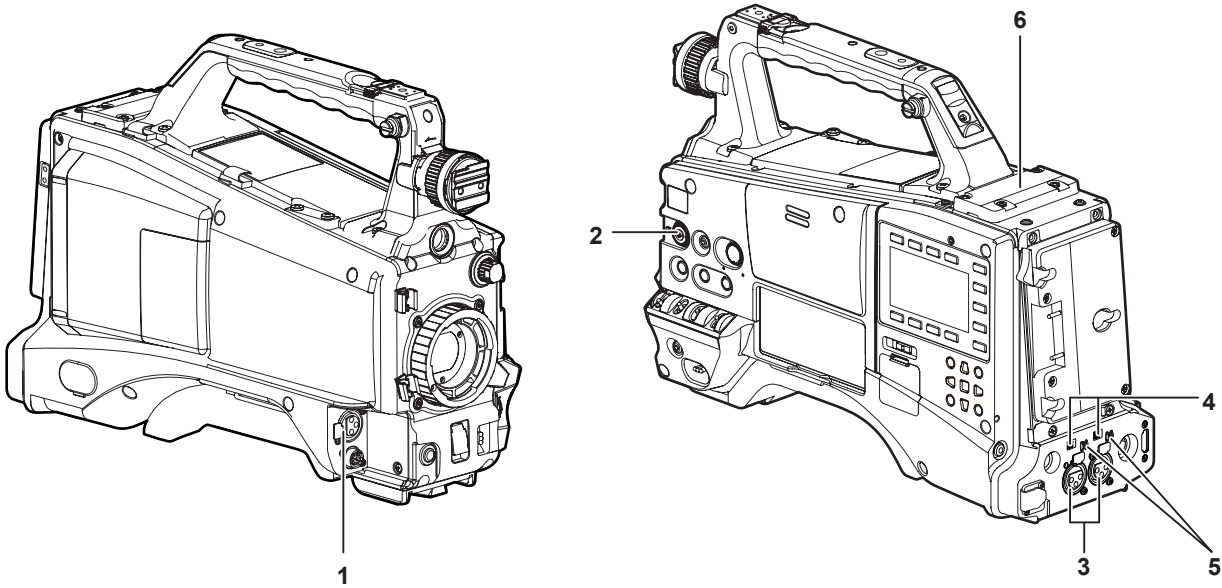

### 1 <MIC IN> (microphone input) terminal (page 96)

- Connect the microphone (optional).
- Can also be used for connecting the phantom microphone. When using the phantom microphone, set the [F.MIC POWER] item on the setting menu [AUDIO SETUP] screen to [ON]. When it is set to [ON] and a microphone is not connected, low-frequency noise may occur. This is not a problem when a microphone is connected.

### 2 <F.AUDIO LEVEL> (audio recording level adjustment) dial (page 60)

- Adjust the recording level of audio channels 1 to 4.
- When the adjustment method for the recording level is set to [MANU] on the [AUD02:INPUT] screen of SmartUI, the recording level of the audio channel can be adjusted with this dial.
- Set which input terminal operation of this control works on by the [FRONT VR CH1], [FRONT VR CH2], [FRONT VR CH3], and [FRONT VR CH4] items on the setting menu [AUDIO SETUP] screen.

### 3 <AUDIO IN CH1/3>, <AUDIO IN CH2/4> (audio input channel 1/3, 2/4) terminals (page 96)

Connect audio equipment or the microphone.

### 4 <LINE>/<MIC> (line input/microphone input) selector switch (page 96)

Switch the audio input signal connected to <AUDIO IN CH1/3> and <AUDIO IN CH2/4> (audio input channels 1/3, 2/4) terminals.

|        |   |
|--------|---|
| <LINE> | Audio input signals from line-input audio equipment |
| <MIC>  | Audio input signal from the microphone              |

### 5 Microphone input <+48V> ON/OFF switch (page 155)

Turn on/off the power supply to the microphone connected to the <AUDIO IN CH1/3> and <AUDIO IN CH2/4> (audio input channels 1/3, 2/4) terminals.

|        |  |
|--------|--|
| <+48V> | Supplies +48 V power to the microphone.  |
| <OFF>  | Does not supply power to the microphone. |

### NOTE

- When microphone input <+48V> is set and microphones are not connected to the <AUDIO IN CH1/3> and <AUDIO IN CH2/4> terminals, low-frequency noise may occur. This is not a problem when a microphone is connected.

### 6 Wireless slot (page 96)

Mount the UniSlot wireless receiver (optional).

## Audio (output) function section

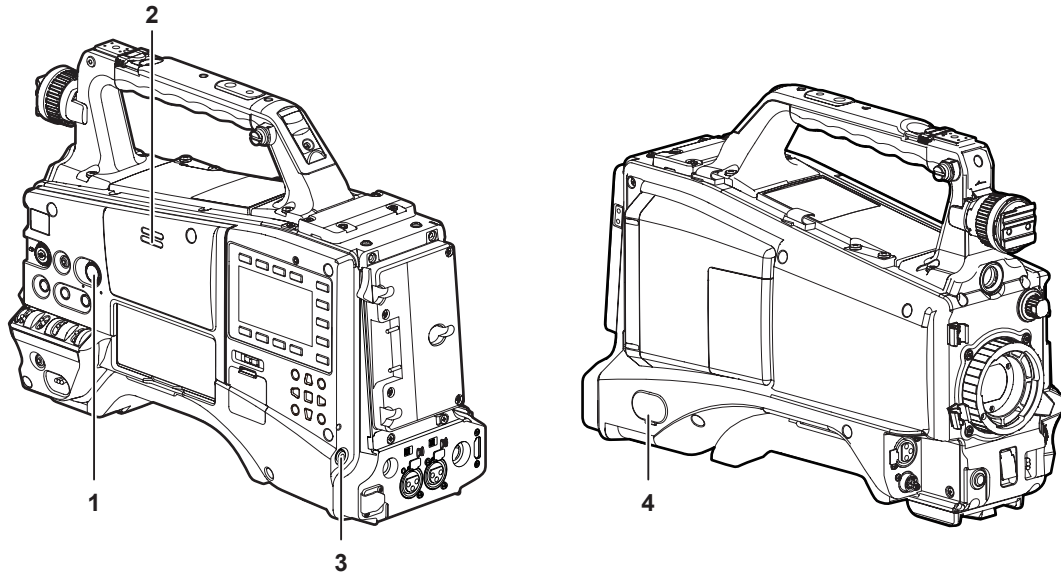

- 1 <MONITOR> (volume adjustment) dial**  
Adjust the volume of the monitor speaker and earphone.
- 2 Speaker**  
During recording, EE audio can be monitored, and during playback, playback audio can be monitored.  
Audio from the speaker is automatically turned off when an earphone is connected to the <PHONES> terminal.
- 3 <PHONES> (earphone) terminal (mini jack)**  
This is the terminal for connecting the audio monitor earphone. (stereo)
- 4 <AUDIO OUT> terminal (page 140)**
- Output audio signals recorded on audio channel 1/2 or 3/4.
  - Select output signals on the [AUD03:MONI] screen of SmartUI.

## Shooting and recording/playback functions section

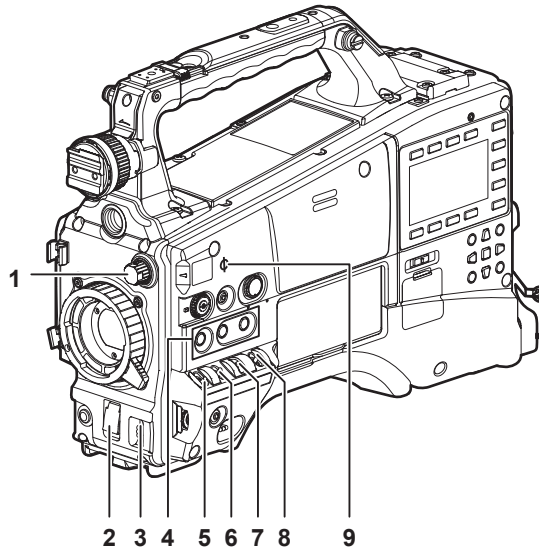

### ■ Shooting and recording (Camera unit)

#### 1 <ND FILTER> (filter switching) dial (page 35)

Adjust the amount of light entering the MOS sensor. Used when there is strong natural light.

| Dial position | Setting  | Description   |
|---------------|----------|---|
| <1>           | <CLEAR>  | The ND filter is not used.                                      |
| <2>           | <1/4ND>  | The amount of light entering the MOS sensor is reduced to 1/4.  |
| <3>           | <1/16ND> | The amount of light entering the MOS sensor is reduced to 1/16. |
| <4>           | <1/64ND> | The amount of light entering the MOS sensor is reduced to 1/64. |

#### 2 Shutter switch (page 56)

Turn on/off the electronic shutter.

|       |   |
|-------|---|
| <OFF> | The electronic shutter is disabled.                 |
| <ON>  | The electronic shutter is enabled.                  |
| <SEL> | The speed of the electronic shutter can be changed. |

This is a spring switch. Each turn towards the <SEL> side alters the shutter speed.

#### 3 <AUTO W/B BAL> switch (page 53)

|       |   |
|-------|---|
| <AWB> | White balance is automatically adjusted. When this switch is operated with the <WHITE BAL> switch on the side set to the <A> or <B> position, adjustment is performed in several seconds and adjustment values are stored in memory. When the <WHITE BAL> switch is at the <PRST> position, the preset color temperature can be changed by setting the <AUTO W/B BAL> switch towards the <AWB> side, and setting it once again towards the <AWB> side while the color temperature is displayed. |
| <ABB> | Black balance is automatically adjusted.  |

#### 4 <USER> buttons (<USER MAIN>/<USER1>/<USER2>) (page 59)

Assign user-selected functions to each button. Pressing each button performs the assigned function.

#### 5 <DISP/MODE CHK> switch (page 76)

This is the spring switch to check the shooting status of the camera.

- When it is pushed towards the <OFF> side, all displays other than the operating mode display and frame display such as area, and the counter, marker, and safety zone on the viewfinder screen turn off.

- Push it towards the <CHK> side to display all information such as the setting status of the shooting functions and functions assigned to the <USER> buttons (<USER MAIN>/<USER1>/<USER2>) on the viewfinder screen during camera standby or shooting. While the information is displayed, push it towards the <CHK> side again to display the proxy and network setting status (only when the option is installed). The mode check information display disappears after approximately three seconds.

#### 6 <GAIN> switch (page 53)

- Switch the video amplifier gain according to the lighting conditions under which you are shooting.
- The gain values for the <L>/<M>/<H> positions can be set by [LOW GAIN], [MID GAIN] or [HIGH GAIN] items on the setting menu [SW MODE] screen.
- Factory settings are L=0 dB, M=6 dB and H=12 dB.

#### NOTE

- When microphone input <+48V> is set and microphones are not connected to the <AUDIO IN CH1/3> and <AUDIO IN CH2/4> terminals, low-frequency noise may occur. This is not a problem when a microphone is connected.

#### 7 <OUTPUT>/<AUTO KNEE> selector switch

Select the video signals output to the memory, viewfinder and video monitor from the camera unit.

|                   |  |
|-------------------|--|
| CAM.AUTO KNEE ON  | Video captured on the camera is output and the auto knee function is activated. Instead of the auto knee function, the dynamic range stretcher (DRS) function can be assigned. |
| CAM.AUTO KNEE OFF | Video captured with the camera is output and the auto knee function is not activated. The knee point is fixed to the level set by menu operations.                             |
| <BARS>            | The color bar signal is output. The auto knee function is disabled.  |

#### NOTE

- Auto knee function  
Usually, when you adjust levels to shoot people or scenery against a strongly lit background, the background will be totally white-out, with buildings and other objects blurred. In such a case, the auto knee function reproduces the background clearly. The auto knee function is effective when shooting the following scenes:
  - The subject is a person positioned in the shade under a clear sky.
  - The subject is a person inside a car or a building, and you also want to capture the background visible through a window.

- The subject is a high-contrast scene.

**8 <WHITE BAL> (white balance memory selector) switch (page 53)**

Select the white balance adjustment method.

<PRST>

Set the switch to this position when you have no time to adjust the white balance.

- The factory setting is 3200 K.
- The color temperature can be changed successively to 3200 K, 5600 K, and the user-specified variable value by the setting menu or by pushing the <AUTO W/B BAL> switch towards the <AWB> side, and pushing the <AUTO W/B BAL> switch towards the <AWB> side again while the color temperature is displayed. The variable value can be set at SmartUI. (page 139)

It can be set using the jog dial button, by assigning the [F.JOG CT] function to the <USER> button. (page 59)

<A>/<B>

Pressing the <AUTO W/B BAL> switch towards <AWB> automatically adjusts the white balance and saves the adjusted value to memory A or B.

You can also assign the auto tracking white balance (ATW) function to <B> in the setting menu. (page 54)

**9 Focal plane index <Φ>**

Indicates the focal plane of the MOS sensor.

It provides a reference for making accurate focal distance measurements from the subject.

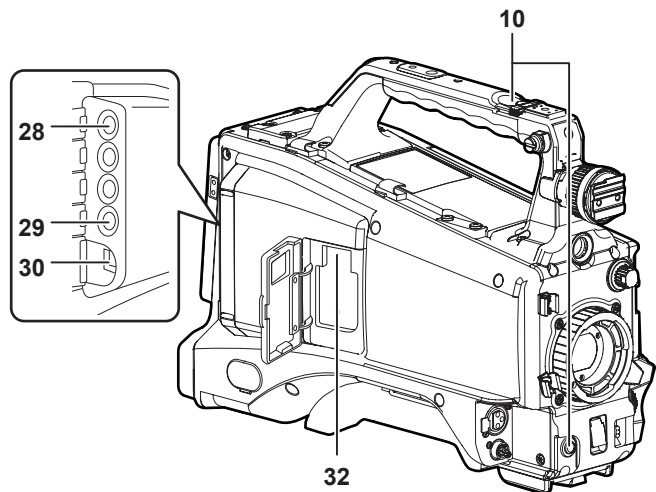
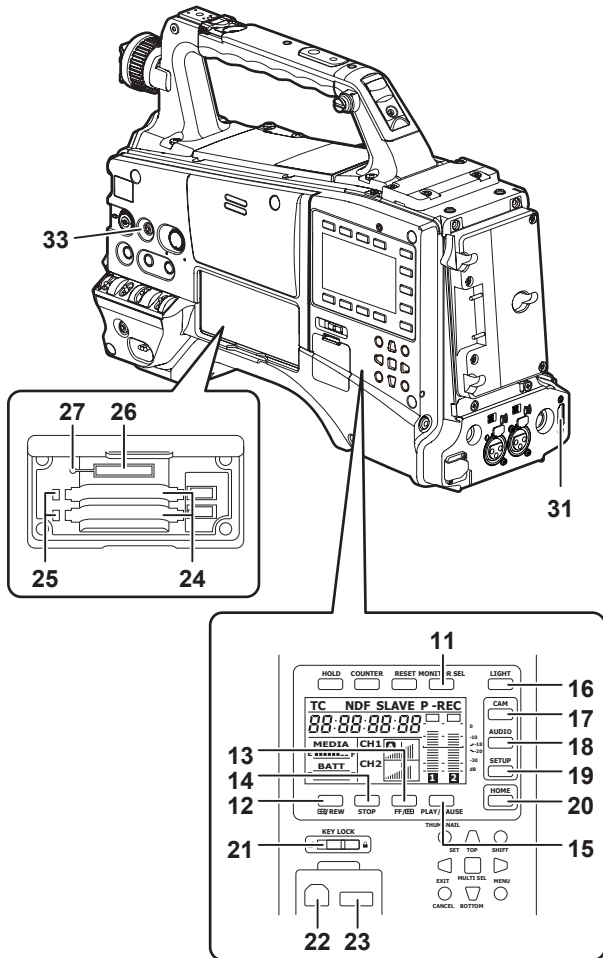

■ Shooting and recording/playback functions section (Recording unit)

**10 <REC> button (page 36)**

Press this button to start recording, and press again to stop recording. This button has the same function as the VTR button on the lens side.

**11 <MONITOR SEL> button**

Switch the audio channel that is output to the speaker, the <PHONES> terminal, and the <AUDIO OUT> terminal to [CH1/2] or [CH3/4] each time you press the button. The channel display of the audio channel level meter is switched together.

When the screen other than the [HOME] screen of SmartUI is displayed, the function corresponding to each setting screen is executed.

**12 <◀◀/REW> (rewind) button**

Press this button during a pause to perform fast-reverse playback. Press it during playback to perform fast-reverse playback at approximately 4x speed.

If it is pressed with playback paused, the clip being played back is paused at its start point (cued state).

When the screen other than the [HOME] screen of SmartUI is displayed, the function corresponding to each setting screen is executed.

**13 <FF/▶▶> (fast forward) button**

Press this button during a pause to perform fast playback.

Press it during playback to perform fast playback at approximately 4x speed.

If it is pressed with playback paused, the clip being played back is paused at the start point of the next clip (cued state).

When the screen other than the [HOME] screen of SmartUI is displayed, the function corresponding to each setting screen is executed.



**14 <STOP> (stop) button**

Press this button to stop playback.  
Also press it to stop interval recording and one-shot recording, or to end combining of clips in one-clip recording.  
When the screen other than the [HOME] screen of SmartUI is displayed, the function corresponding to each setting screen is executed.

**15 <PLAY/PAUSE> (play/pause) button**

Press this button to view the playback image using the viewfinder screen or the monitor screen.  
Pressing this button during playback pauses playback.  
When the screen other than the [HOME] screen of SmartUI is displayed, the function corresponding to each setting screen is executed.

**16 <LIGHT> button**

Control lighting of SmartUI. Each press toggles lighting of SmartUI on and off.

**17 <CAM> button (page 138)**

Display the [CAMERA] screen on SmartUI.

**18 <AUDIO> button (page 140)**

Display the [AUDIO] screen on SmartUI.

**19 <SETUP> button (page 142)**

Display the [SETUP] screen on SmartUI.

**20 <HOME> button (page 135)**

Display the [HOME] screen on SmartUI.

**21 <KEY LOCK> switch (page 135)**

Disable button operations related to SmartUI and thumbnail operations. However, <LIGHT> button operation is available.

**22 <USB2.0> terminal (device) (page 146)**

**23 <USB2.0> terminal (host) (page 146)**

Connect the USB 2.0 cable.  
When the [PC MODE] item on the setting menu [PC/USB/LAN] screen is set to [ON], data transfer using USB 2.0 is enabled.  
In this state, recording/playback and clip operations on the camera are limited.

**24 P2 card insertion slot**

**25 P2 card access LED (page 33)**

Indicate the access status of recording and playback of each card.

**26 SD memory card insertion slot (page 82)**

This is the insertion slot for the SD memory card (optional). Use the SD memory card for recording/opening the setting menu and lens files for the camera, or uploading metadata or proxy recording (extra-cost option), etc.



- Cautions in using SD memory cards
  - On the camera, use SD memory cards that are compliant with the SD standard or the SDHC standard.
  - MMC (Multi Media Card) cannot be used. (Bear in mind that taking pictures may no longer be possible if you do use them.)
  - When using miniSD/microSD cards with the camera, always install the adaptor specially designed for miniSD/microSD cards. (The camera will not work properly if only the miniSD/microSD adaptor is installed. Make sure that the card has been inserted into the adaptor before use.)
  - Use of Panasonic SD memory cards and miniSD/microSD cards is recommended. Be sure to format cards on the camera before use.
  - Any SD memory card with a capacity of 8 MB to 2 GB and any SDHC memory card up to 32 GB can be used on the camera. Also, when performing proxy recording (extra-cost option), use SDHC memory cards or SD memory cards with a capacity of 256 MB to 2 GB marked "High Speed", etc.
  - For the latest information not available in the Operating Instructions, visit the support desk at the following website:

<http://pro-av.panasonic.net/>

**27 Busy (active status indication) lamp (page 83)**

Indicate the active status of the SD memory card, and is illuminated when the card is active.



- Do not insert or remove the card while the lamp is lit. This might damage the SD memory card.

**28 <SDI OUT/IN (OP)> terminal (page 49)**

Output the SDI signal.

- By installing the HD/SD SDI input board (optional), SDI signals can be input. (page 167)

**29 <MON OUT> terminal (page 49)**

This is the video output terminal for the monitor. Video independent from the <SDI OUT/IN (OP)> terminal can be output. Also, HD SDI signal or down-converted SD SDI signal, or VBS signal can be selected on the [SET02:MON/HDMI FORMAT] screen of SmartUI. Cross-conversion and up-conversion are not supported.

**30 <LAN> terminal (100BASE-TX)**

Enabled when the network function (extra-cost option) is installed. For the cable to be connected to the <LAN> terminal, use the shielded cable.

**31 <HDMI> terminal (page 49)**

**32 <USB2.0> terminal (sub-host)**

Attach the wireless module AJ-WM30 (optional). This can also be used to attach a USB cable that connects the UPLINK device and the camera when the optional Upgrade Software Key (AG-SFU603G: UPLINK device control function (extra-cost option)) is installed.

**33 <FOCUS ASSIST> button (page 80)**

Turn on/off the function for enlarging the video at the center of the screen.

## Menu operation section and thumbnail operation section

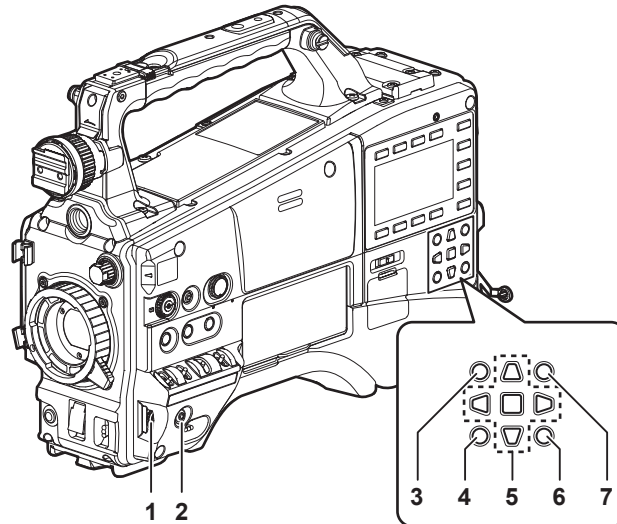

### 1 Jog dial button (page 116)

- With the setting menu open, navigate through setting menu pages, select items, and set values.
- Turn the jog dial button downwards or upwards while the setting menu is displayed to move the menu cursor downwards and upwards, respectively. Press the jog dial button to fix the settings.
- When the shutter switch is set to <ON> and synchro scan is selected without the menu opened, the synchro scan speed can be adjusted.
- When the white balance setting is variable, the white balance variable value in the jog dial button can be adjusted by pressing the <USER MAIN>, <USER1>, and <USER2> buttons that were assigned the [F.JOG CT] function.

### 2 <MENU> button (page 116)

- Hold down this button to display the setting menu screen on the viewfinder screen. Press the button again to return to the original image.
- Button operations are not accepted while thumbnails are displayed or during recording.

### 3 <THUMBNAIL> button (page 103)

Press the button to display the thumbnail screen on the viewfinder screen and the monitor connected to the camera. Button operations are disabled during recording and playback.

### 4 <EXIT>/<CANCEL> buttons (page 103)

Restore the display to the previous state while the thumbnail menu or property screen is displayed. Also, pressing this button with the <SHIFT> button held down makes it function as a cancel button, which is convenient when batch-canceling clip selections.

### 5 Cursor/<SET> button (page 103)

Operate the setting menu, menu bars and thumbnails. The four triangular buttons are the cursor buttons, and the square button in the center is the <SET> button.

### 6 <THUMBNAIL MENU> button (page 103)

Press this button with the thumbnail displayed to move to the thumbnail operations, allowing clip deletion operation, etc.

### NOTE

- Use the cursor/<SET> button and the <EXIT>/<CANCEL> buttons to select thumbnails or operate menus. (page 103)

### 7 <SHIFT> button (page 103)

Press this button with other buttons held down at the same time.

- <SHIFT> button + cursor button ( $\Delta/\nabla$ )  
This moves the pointer to the thumbnail of the clip at the start or the end in the thumbnail screen.
- <SHIFT> button + <SET> button  
Select all clips from the previously selected clip up to the clip at the pointer position.

- <SHIFT> button + <EXIT>/<CANCEL> button

This works as the cancelation function. (page 26)

Operations with the <SHIFT> button held down are displayed at the bottom of each button.

## Time code section

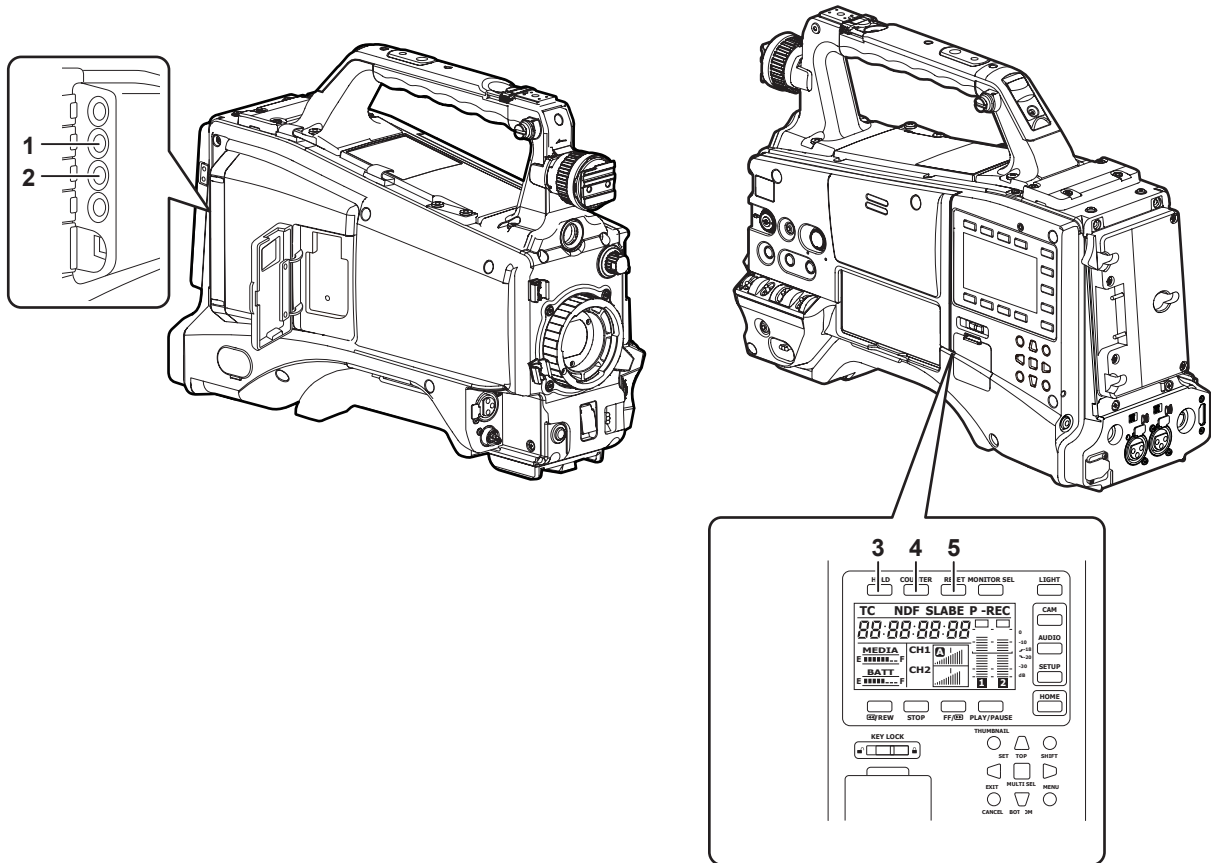

### 1 <GENLOCK IN> terminal (page 67)

Input reference signals when setting the generator lock on the camera unit, or when externally locking the time code.

#### NOTE

- Supply Y signals of HD or or composite signals as an input signal. However, the sub-carrier of the composite signal on the camera cannot be externally locked.

### 2 <TC IN/OUT> terminal (page 61)

- Switch input/output in the menu.
- Input the reference time code to this terminal when the time code is locked.
- Connect to the time code input terminal of the external device when locking the time code of the external device to the time code on the camera. (page 68)

### 3 <HOLD> button

The time data indication on the counter display area is retained for the duration that this button is held down. However, the time code generator continues to advance. Press again reactivates the counter. This function is used to learn the time code or counter value of a particular recorded scene.

When the screen other than the [HOME] screen of SmartUI is displayed, the function corresponding to each setting screen is executed.

### 4 <COUNTER> (counter display selector) button (page 29)

Each press of this button displays the counter value, time code, user bits, and frame rate information on the viewfinder screen.

When the screen other than the [HOME] screen of SmartUI is displayed, the function corresponding to each setting screen is executed.

### 5 <RESET> button

Reset the counter value in the time code display area to 0 (zero).

When the screen other than the [HOME] screen of SmartUI is displayed, the function corresponding to each setting screen is executed.

## Warning and status display section

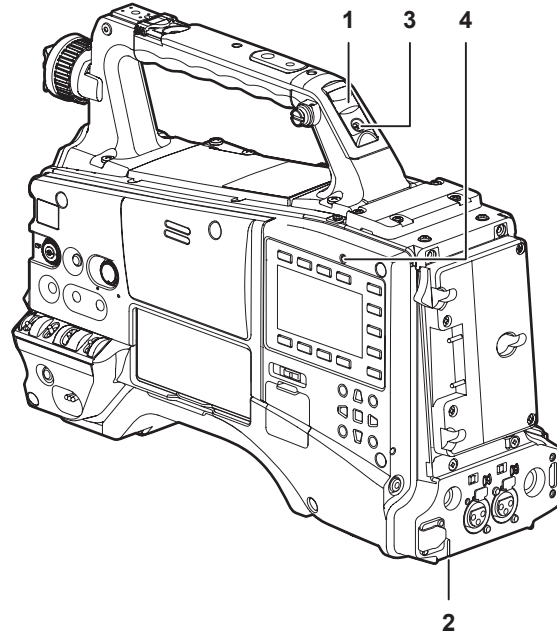

### 1 Back tally lamp

When the back tally switch is set to on, the lamp acts in the same way as the front tally lamp at the viewfinder.

### 2 Rear tally lamp

When the back tally switch is set to on, the lamp acts in the same way as the back tally lamp.

### 3 Back tally switch

Control the action of the back and rear tally lamps.

|            |   |
|------------|---|
| <b>ON</b>  | The back and rear tally lamps are enabled.  |
| <b>OFF</b> | The back and rear tally lamps are disabled. |

### 4 <WARNING> lamp (page 157)

Start flashing or is illuminated if something unusual occurs in the memory.

## SmartUI display ([HOME] screen)

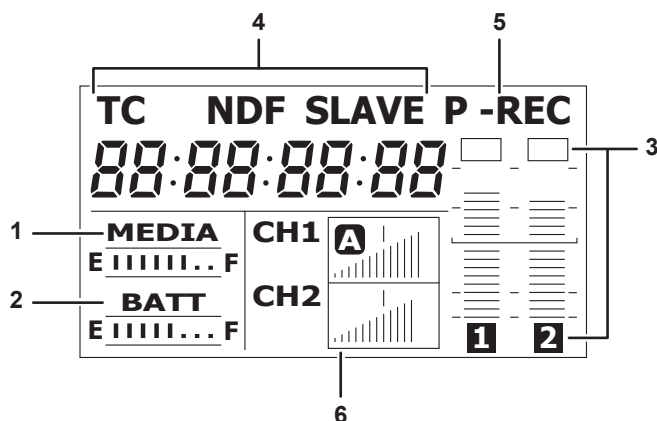

### 1 Media remaining space indicator bar

Indicates the remaining free space in the P2 card using a 7-segment display. Each segment is equivalent to three minutes, and the decreasing P2 card remaining time is indicated by the segments going out one segment at a time.

### 2 Battery charge level indicator bar

When a battery with a digital indication (% indication) is used, all seven segments up to the F position light if the battery charge level is 70% or higher. When the battery charge level falls below 70%, the segments go out one by one for each 10% drop.

### 3 Audio channel level meter

One segment indicates 2 dB increment, with the smallest indication being -36 dB and the [OVER] indication displayed by ■ at the topmost position. Each time you press the <MONITOR SEL> button, CH1/CH2, stereo, CH3/CH4 are switched, and the channel display of the level meter is switched together. (page 140) Channels output to the monitor audio are displayed in white dropout. When the stereo is selected, both channels are displayed in white dropout.

### 4 Time code indications

Each time you press the <COUNTER> button, the display changes in the order of [CLIP] → [TC] → [tc] → [UB] → [FR] → [CLIP] (viewfinder screen not displayed)\* → [CLIP].

\* The time code on the viewfinder screen is hidden.

|  |  |
|--|--|
| [CLIP]   | Indicates the counter value in hours:minutes:seconds.  |
| [TC]   | Indicates the time code value in hours:minutes:seconds:frames.   |
| [tc]   | Indicates the time code value in hours:minutes:seconds:frames. The frame is displayed after converting the frame digit to 24 frames. |
| [UB]   | Indicates the user bits value.   |
| [FR]   | Indicates the information of the frame rate at which recording is performed.   |
|  | [60i] 60i interlace mode (60 fields/sec)   |
|  | [60P] 60P progressive mode (60 frames/sec)   |
|  | [30P] 30P progressive mode (30 frames/sec)   |
|  | [24P]* 24P progressive mode (24 frames/sec)  |
|  | [24PA]* 24P advance mode (24 frames/sec)   |
|  | [50i] 50i interlace mode (50 fields/sec)   |
|  | [50P] 50P progressive mode (50 frames/sec)   |
|  | [25P] 25P progressive mode (25 frames/sec)   |
| * In the case of 24P and 24PA, the sequence number is indicated. |  |

|         |  |
|---------|--|
| [NDF]   | Indicated when the time code is in the non-drop frame mode.  |
| [DF]    | Indicated when the time code is in the drop frame mode.  |
| [HOLD]  | Indicated when the time code generator/read value is held.   |
| [F-RUN] | Indicated when the time code is set to advance continuously regardless of the recording operation. |
| [R-RUN] | Indicated when the time code is set to advance only during recording.                              |
| [SLAVE] | Indicated when the time code is externally locked.   |

### 5 Recording mode display

|         |                                |
|---------|--------------------------------|
| [REC]   | Standard recording             |
| [P-REC] | When pre-recording mode is set |
| [i-REC] | Interval recording setting     |
| [L-REC] | Loop recording setting         |

### 6 Status information

|                             |   |
|-----------------------------|---|
| Audio level display         | Indicates whether audio CH1/CH3 or CH2/CH4 audio volume and audio level are in the auto adjustment mode. In the auto adjustment mode, [A] is displayed.   |
| Audio input                 | Indicates the input settings of audio CH1, CH2, CH3, and CH4.   |
| At a USB connection         | Indicated when the [PC MODE] item on the setting menu [PC/USB/LAN] screen is set to [ON], and a device selected at [PC MODE SEL] is connected. <ul style="list-style-type: none"> <li>In the USB host mode: [USB HOST CONNECTED]/[USB HOST DISCONNECTED]</li> <li>In the USB device mode: [USB DEVICE CONNECTED]/[USB DEVICE DISCONNECTED]</li> </ul> |
| Error, card warning display | Indicates the error code when something has caused an error on the camera.  |

## Chapter 3 **Recording and Playback**

---

This chapter describes the basic procedure for recording and playback. It also describes special photographic methods such as pre-recording and interval recording.

## Setting the date/time of the internal clock

The value of the time [CLOCK SETTING] is recorded to content (clips) and affects the thumbnail playback order. Before recording, be sure to check and set [CLOCK SETTING] and [TIME ZONE].

The following describes the procedure for setting the date and time to September 1, 2012 and 5:20 p.m.

- 1 Set the <POWER> switch to <ON>.
- 2 Select the [TIME ZONE] item on the setting menu [OTHER FUNCTIONS] screen, and press the jog dial button.  
For details, refer to “Setting menu basic operations” (page 116).
- 3 Set the time difference from Greenwich mean time using the jog dial button.

Set this by referring to the time zone table.

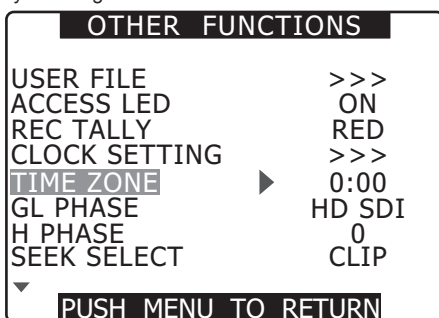

### Time zone table

| Time difference | Region            | Time difference | Region           |
|-----------------|-------------------|-----------------|------------------|
| 00:00           | Greenwich         | +01:00          | Central Europe   |
| -00:30          |                   | +01:30          |                  |
| -01:00          | Azores            | +02:00          | Eastern Europe   |
| -01:30          |                   | +02:30          |                  |
| -02:00          | Mid-Atlantic      | +03:00          | Moscow           |
| -02:30          |                   | +03:30          | Tehran           |
| -03:00          | Buenos Aires      | +04:00          | Abu Dhabi        |
| -03:30          | Newfoundland      | +04:30          | Kabul            |
| -04:00          | Halifax           | +05:00          | Islamabad        |
| -04:30          |                   | +05:30          | Bombay           |
| -05:00          | New York          | +06:00          | Dakar            |
| -05:30          |                   | +06:30          | Yangon           |
| -06:00          | Chicago           | +07:00          | Bangkok          |
| -06:30          |                   | +07:30          |                  |
| -07:00          | Denver            | +08:00          | Beijing          |
| -07:30          |                   | +08:30          |                  |
| -08:00          | Los Angeles       | +09:00          | Tokyo            |
| -08:30          |                   | +09:30          | Darwin           |
| -09:00          | Alaska            | +10:00          | Guam             |
| -09:30          | Marquesas Islands | +10:30          | Lord Howe Island |
| -10:00          | Hawaii            | +11:00          | Solomon Islands  |
| -10:30          |                   | +11:30          | Norfolk Island   |
| -11:00          | Midway Islands    | +12:00          | New Zealand      |
| -11:30          |                   | +12:45          | Chatham Islands  |
| -12:00          | Kwajalein Atoll   | +13:00          |                  |
| +00:30          |                   |                 |                  |

### NOTE

- Clock accuracy is a lunar inequality of approximately ±30 seconds with the power off.
- When accurate time is required, check and reset the time. If the value set to the [TIME ZONE] item on the setting menu [OTHER FUNCTIONS] screen is changed after the time is set, the display and recorded time changes to the time with the time difference added.

- 4 Select [CHANGE] at the [CLOCK SETTING] item on the setting menu [OTHER FUNCTIONS] screen, and press the jog dial button.

The [CLOCK SETTING] screen is displayed.

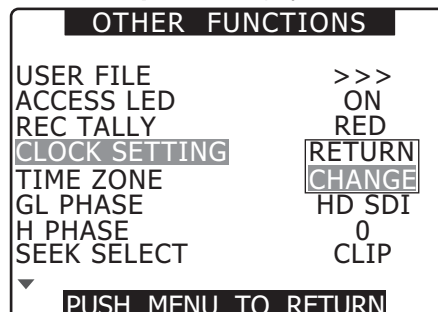

- 5 Turn the jog dial button to select [YEAR], and press the jog dial button.



- 6 Turn the jog dial button, set [YEAR] to [2012], and press the jog dial button.

The year can be set from [2000] to [2037].

- 7 Turn the jog dial button to select [MONTH], and press the jog dial button.

- 8 Turn the jog dial button, set [MONTH] to [SEP], and press the jog dial button.

- 9 By the same operation for [YEAR]/[MONTH], set [DAY]/[HOUR]/[MINUTE].

[HOUR] is displayed in the 24-hour format.



## P2 card

### Inserting a P2 card

#### NOTE

- When using the camera for the first time, be sure to set the time data beforehand. (page 31)

1 Set the <POWER> switch to <ON>.

2 Open the slot cover.

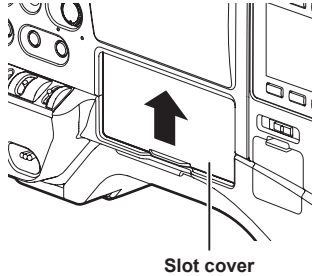

3 Insert a P2 card into the P2 card slot.

- Insert the card until the eject button pops out.
- Insert the card with the logo facing up.

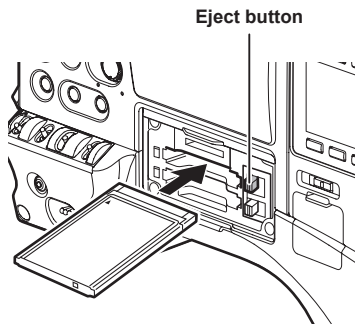

4 Press the eject button that pops up to the right.

- When a P2 card is inserted, the P2 card access LED for the appropriate slot indicates the status of the P2 card. (page 33)

P2 card access LED

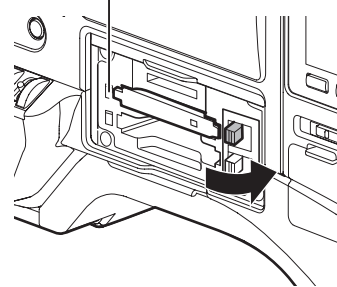

5 Close the slot cover.

#### NOTE

- To prevent cards from falling out, dust from entering and reduce the risk of exposure to static electricity, close the slot cover before moving the camera.
- Be sure to format P2 cards only on a P2 device.

### Removing a P2 card

1 Open the slot cover.

2 Raise the eject button.

3 Press in the eject button to remove the P2 card.

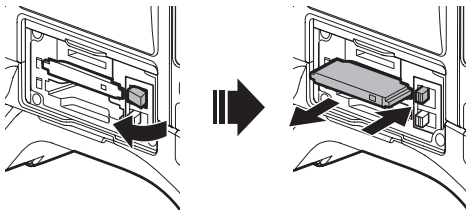

#### NOTE

- After insertion, do not remove the P2 card while it is being accessed or recognized (the P2 card access LED is flashing orange). Doing so may result in a malfunction.
- If the P2 card is removed while being accessed, [TURN POWER OFF] is displayed on the viewfinder screen, the camera gives out a warning indication by an alarm or <WARNING> lamp, etc. All P2 card access LEDs flash rapidly in orange, so, if this is the case, turn off the power. (page 157)
- If the P2 card is removed while being accessed, clips on it may become irregular. Check the clips and restore them, if required. (page 107)
- If the P2 card being formatted is removed, formatting of the P2 card is not guaranteed. In this case, [TURN POWER OFF] is displayed on the viewfinder screen displays. Turn off the power then back on again, and reformat the P2 card.

- If a P2 card is inserted while another card is being played back, the inserted card is not recognized and the P2 card access LED for that card does not light. P2 card recognition starts when playback of the other card ends.
- Even if a P2 card is inserted in a vacant card slot during recording, the media may not be recognized immediately in the following instance:
  - Immediately after a pre-recording
- The P2 card access LED can be set to off at all times at the [ACCESS LED] item on the setting menu [OTHER FUNCTIONS] screen. In this case, turn off the power before removing the card, or, after the card is inserted or after operation (recording, playback, etc.) has stopped, wait for the charging to complete before removing the card.
- If thumbnails are displayed, the thumbnail screen will be canceled when the P2 card is removed.



**Preventing accidental erasure**

To prevent the content of a P2 card from being accidentally erased, set the write-protect switch on the P2 card to the Protect position.

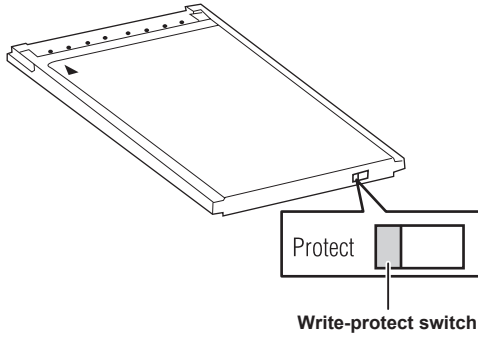

**NOTE**

- Write-protect switch can be switched while the card is being accessed (during recording or playback), but does not take effect until accessing of the card stops.

**P2 card access LEDs and status of P2 cards**

| P2 card access LED      | P2 card status                |   | Mode check display* |
|-------------------------|-------------------------------|---|---------------------|
| Is illuminated green    | Recording possible            | Reading/writing both possible   | [ACTIVE]            |
| Is illuminated orange   | Recording target              | Reading/writing both possible. The card is currently recording target (including loop recording, interval recording, one-shot recording). | [ACTIVE]            |
| Flashing orange         | Accessing card                | Reading/writing are currently being performed.  | [ACCESSING]         |
| Flashing orange rapidly | The card is being recognized. | The P2 card is being recognized.  | [INFO READING]      |
| Flashing green slowly   | Card full                     | There is no free space on the P2 card. The card can only be read.   | [FULL]              |
|                         | Write protect                 | The write-protect switch on the P2 card is at the Protect position. The card can only be read.  | [PROTECTED]         |
| Off                     | Card not supported            | This card cannot be used on the camera. Replace the card.   | [NOT SUPPORTED]     |
|                         | Format error                  | The P2 card is not properly formatted. Reformat the card.   | [FORMAT ERROR]      |
|                         | No card                       | No P2 card is inserted. The card is waiting to be recognized.   | [NO CARD]           |

\* The mode check is displayed on the viewfinder screen. For details, refer to “Viewfinder status display” (page 70).

**P2 card recording time**

■ **P2 cards supported on the camera**

Optional P2 cards with a capacity of 4 GB to 64 GB can be used with the camera. (As of September, 2014)

**NOTE**

- AJ-P2C002SG (2 GB) cards cannot be used.
- The driver installed on the camera may be required to be updated depending on the type of P2 card. (page 160)
- For the latest information not available in the Operating Instructions, visit the support desk at the following website:  
<http://pro-av.panasonic.net/>

■ **P2 card recording times**

(When a 64 GB card is used)

| System mode      | Recording format (codec) | Recording time  |
|------------------|--------------------------|-----------------|
| HD (1080i, 720P) | AVC-I 100<br>DVCPRO HD   | Approx. 64 min  |
|                  | AVC-I 50                 | Approx. 128 min |
| SD (480i)        | DVCPRO50                 | Approx. 128 min |
|                  | DVCPRO<br>DV             | Approx. 256 min |

**NOTE**

- The above table shows values for regular recording. With native recording, even longer recording times are available depending on the system mode. (page 48)
- In the case of 32 GB P2 cards, the recording time becomes 1/2 of the above recording times, in the case of 16 GB P2 cards, the recording time becomes 1/4, and in the case of 8 GB P2 cards, the recording time becomes 1/8.
- Indicated capacities include management and other area, so the space available for recording is less than the values in the table above.

**Dividing clips recorded on P2 cards**

If P2 cards of capacity 8 GB or greater are used on the camera, recording is automatically continued as another clip when a single continuous recording time exceeds the times in the table below. Also, when thumbnails for clips are handled (displayed, deleted, restored, etc.) on P2 devices, they can be handled as a single clip. Clips are sometimes displayed as separate clips in nonlinear editing software and on a computer.

| Recording format (excluding native recording) | Continuous recording time |
|---|---------------------------|
| AVC-I 100<br>DVCPRO HD                        | Approx. 5 min             |
| AVC-I 50<br>DVCPRO50                          | Approx. 10 min            |
| DVCPRO<br>DV                                  | Approx. 20 min            |

**How to handle data recorded on P2 cards**

P2 cards are semiconductor memory cards that are used as the recording medium in the professional video production and broadcasting devices that make up the DVCPRO P2 series.

- Since data recording in the DVCPRO P2 format or AVC-Intra are in a file format, they have excellent compatibility with computers. However, the file structure is a unique format, which in addition to video and audio data in MXF files contains various other important information items. The folder structure links the data as shown below.

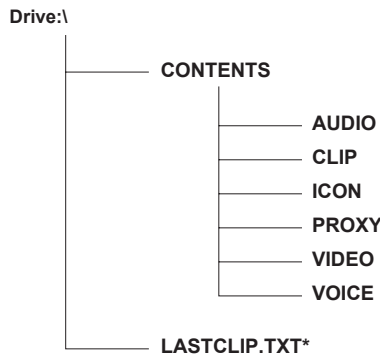

All these folders are required.  
 \*This is the file to which the information of the final clip that was recorded with the P2 device is written.

**NOTE**

- If even part of this information is modified or deleted, the data may no longer be recognized as P2 data, or the memory card may no longer be able to be used with P2 devices.
- When transferring data from a P2 card to a computer, or when rewriting data saved on a computer back to a P2 card, to prevent data loss, be sure to download the special "P2 Viewer Plus" software from the following website and use the downloaded software. For details on the operating environment required for the P2 Viewer Plus, visit the support desk at the following website:  
<http://pro-av.panasonic.net/>
- When using regular IT tools such as Microsoft Windows Explorer or Apple Finder to transfer data to a computer, follow the instructions below. However, be sure to use P2 Viewer Plus when returning data back to a P2 card.
  - Transfer the corresponding CONTENTS folder and LASTCLIP.TXT file together as a set.
  - Do not transfer individual files from the CONTENTS folder.
  - When copying, copy the LASTCLIP.TXT file at the same time as the CONTENTS folder.
  - When transferring the data in multiple P2 cards to a computer, create a folder for each P2 card to prevent clips with the same name from being overwritten.
  - Do not delete data from the P2 card.
  - Be sure to format P2 cards only on a P2 device.

## Basic procedures

This section describes the basic procedures for shooting and recording. Before you actually start shooting, pre-inspect your system to see ensure that it works properly. (page 154)

### Power supply setup to P2 card insertion

- 1 Insert a charged battery pack.
- 2 Turn the <POWER> switch <ON>, and check the battery charge level indicator on the viewfinder screen or the [HOME] screen of SmartUI.

If the battery charge is low, replace with a fully charged battery.

#### NOTE

- If a low battery charge level is indicated even after replacing with a fully charged battery, make sure that the battery has been inserted correctly. (page 128)

- 3 Insert a P2 card, make sure that the P2 card access LED is illuminated orange or green, and then close the slot cover.

When two P2 cards are inserted in the P2 card slots, the P2 card with the smaller slot number will be recorded to first. Note, however, that regardless of the slot number, if a P2 card is inserted later, that P2 card will not be accessed until the previously inserted P2 card has been recorded to.

#### • Example: When P2 cards are inserted in two slots

If both slots contain P2 cards, the P2 cards are recorded in order slot number 1 → 2. However, if the P2 card is slot number 1 is removed and then re-inserted, the P2 cards will be used in the following order: slot number 2 → 1.

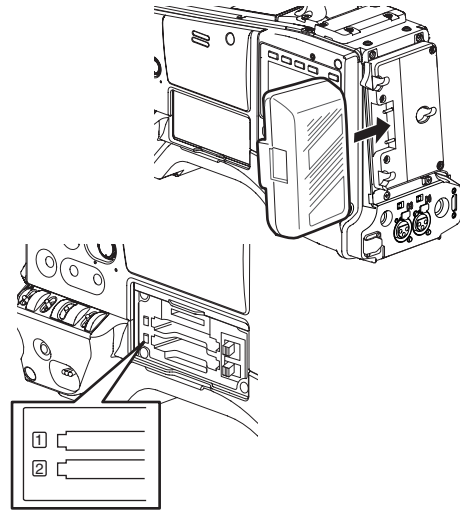

Note that the recording P2 card number is held even if the power is turned off, and when the power is next turned on, recording will continue on the same P2 card written before powering off.

### Shooting and recording switch settings

After turning on the power and inserting the P2 card, set the switches as follows before starting to use the camera.

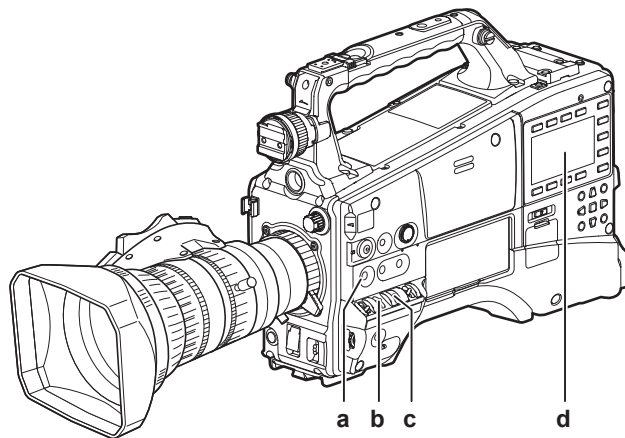

#### a: <USER MAIN> button

The [Y GET] function is assigned in the factory setting.

#### b: <GAIN> switch

Normally, set this to <L> (0 dB). If conditions are too dark, set gain to an appropriate value.

#### c: <OUTPUT> switch

Set this switch to CAM.AUTO KNEE ON.

#### d: SmartUI

- 1 On the [SET01:TC/UB] screen, set it to [F-RUN] or [R-RUN].
- 2 On the [AUD02:INPUT] screen, set [LVL] to [AUTO].

### For shooting

#### White/black balance adjustment to completion of recording

For shooting, use the following steps.

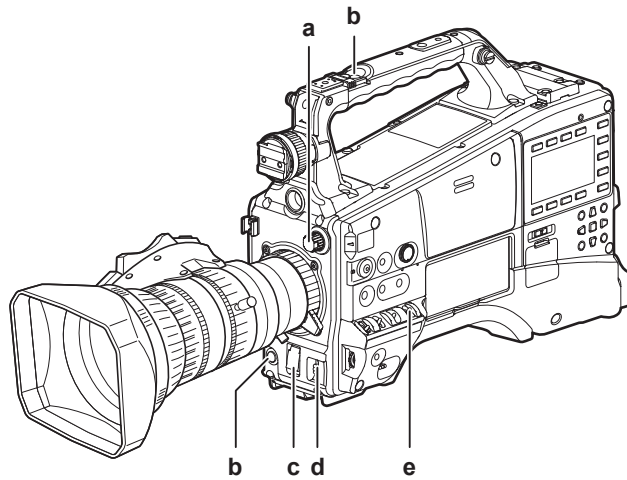

- a: <ND FILTER> dial
- b: <REC> button
- c: Shutter switch
- d: <AUTO W/B BAL> switch
- e: <WHITE BAL> switch

**1** Select a filter by the <ND FILTER> dial according to the light conditions.

**2** Operate the <WHITE BAL> switch.

- **When the white balance is already saved in memory:**
  - Set the <WHITE BAL> switch to <A> or <B>.
- **When neither white or black balance is saved in memory and you have no time to adjust the white balance:**
  - Set the <WHITE BAL> switch to <PRST>.
  - The value can be changed to 3200 K, 5600 K, and the user-specified variable value by pushing the <AUTO W/B BAL> switch towards the <AWB> side, and pushing the <AUTO W/B BAL> switch towards the <AWB> side again while the color temperature is displayed. It can also be set using the jog dial button, by setting a variable value using SmartUI (page 139) or assigning the [F.JOG CT] function to the <USER> button. (page 59)

■ **To adjust the white balance on the spot:**

- Select a filter matched to the lighting conditions, set the <WHITE BAL> switch to <A> or <B>, shoot a white test subject, and adjust the white balance by the following steps.
  - 1) Press the <AUTO W/B BAL> switch towards the <AWB> side to adjust the white balance. (page 53)
  - 2) Set the <AUTO W/B BAL> switch towards the <ABB> side to adjust the black balance. (page 55)
  - 3) Press the <AUTO W/B BAL> switch towards the <AWB> side to adjust the white balance again.

**3** Point the camera at your subject and adjust the focus and zoom.

**4** When using the electronic shutter, set the shutter speed and shutter mode. (page 56)

**5** Press the <REC> button to start recording.

**6** To stop recording, press the <REC> button again.

**NOTE**

- When highly bright subjects (e.g. sun or lighting) are shot, the periphery of the subject might be colored.

**Standard recording**

Pressing the <REC> button starts recording of video and sound on the P2 card.

A group of data consisting of video and sound generated by a single shooting action, together with additional information, is called a “clip”.

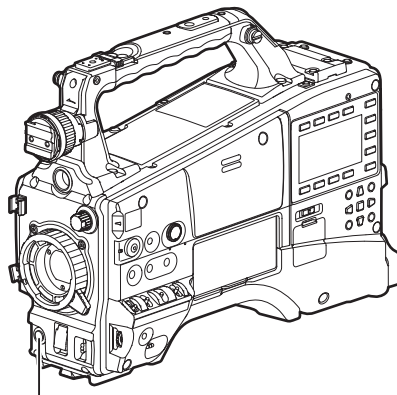

<REC> button

**NOTE**

- In the following cases, it may take time to complete writing to the P2 card. Pressing the <REC> button does not accept operations immediately.
  - When short-burst recording is stopped
  - When stopping recording immediately after recording to two P2 cards

## Standard recording and native recording

You can select between two recording methods: Native recording method that is performed with the shooting frame rate of the camera unchanged, and the standard recording method where the frame rate is pulled down to 59.94 frames.

### Standard recording (Pull-down recording)

Images at 24P are pulled down at a ratio of 2:3, and images at 30P are pulled down at a ratio of 2:2 and recorded at 59.94i or 59.94P.

24PA (2:3:3:2 advanced pull-down) is also supported.

AVC-Intra does not support pull-down recording.

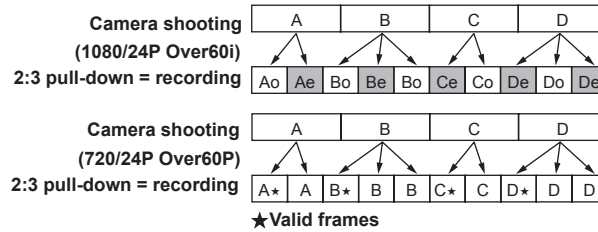

### Native recording

This recording method extracts and records valid frames at the shooting frame rates in AVC-Intra recording in 1080i, and DVCPRO HD and AVC-Intra recording in 720P.

In the case of 720P, recording can be performed 2 to 2.5x longer than that by pull-down recording.

Even in native recording, the rate for outputting camera images and playback images is 59.94 frames that are pulled down.

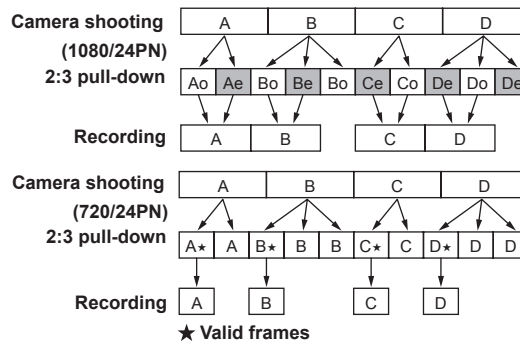

### NOTE

- Recording starts from the top of a 5-frame cycle for 24P/24PA recording, 4-frame cycle for 24PN (native recording), and 2-frame cycle for 30PN (native recording) in 720P. Therefore, the time code may become non-continuous when recording clips continuously in system modes with different recording cycles.
- Just after inserting a P2 card or turning on the power, recording is started using the internal memory of the camera. In this case, recording cannot be stopped until the P2 card is recognized.  
 Push the <DISP/MODE CHK> switch towards the <CHK> side and check the P2 card status on the [SLOT1] and [SLOT2] rows displayed on the viewfinder screen.
- With 24PA (2:3:3:2 advance pull-down) compatible editing software, editing can be performed with less degradation compared with 24P (2:3 pull-down).
- When 24PA-compatible editing system is not used, shoot in the standard 24P mode.

## Variable frame rate (VFR) recording function (extra-cost option)

The variable frame rate (VFR) function can be used by installing the production pack (extra-cost option) on the camera. Time-lapse (undercrank) and high-speed (overcrank) shooting can be performed in the 1080P and 720P modes. You can select between native (PN) and standard (OVER) recording modes.

### Native variable frame rate recording

#### ■ Setting example in the 720-59.94P mode

#### 1 Set the [REC FORMAT] item on the setting menu [SYSTEM SETUP] screen to [AVC-I100/24PN].

For details, refer to “Setting menu basic operations” (page 116).

- It can also be set on the [CAM03:SETUP] screen of SmartUI
- The frame rate can be selected from 1 frame (1P) to 60 frames (60P).

#### 2 Set the [VFR] item on the setting menu [SCENE FILE] screen to [ON], and set the [FRAME RATE] item to match your specific shooting requirement.

#### 3 Press the <REC> button.

Recording is performed in the variable frame rate mode (native variable frame rate).

Combinations of AVC-I 100, AVC-I 50, DVCPRO HD, 30PN, and 24PN can be selected as the recording format.

For details, refer to “List of recording/playback and output formats” (page 49), “[SYSTEM SETUP] screen” (page 122).

### NOTE

- Note the following when recording in the native variable frame rate mode:
  - During recording, the P2 card to record to cannot be switched.
  - Pre-recording, loop recording, interval recording, one-shot recording, and one-clip recording are not possible.
  - During recording, [ON]/[OFF] setting of the [VFR] item does not change even by switching the scene file number.
  - Audio cannot be recorded.\*
  - The time code is fixed to rec-run (R-RUN).\*
  - The thumbnail screen is sometimes created with a one frame delay following the video currently recorded to the P2 card.
  - If the exposure time acquired by operating the frame rate and shutter is 1/12 seconds or longer, images are clipped at the upper limit of the brightness level when the exposure time is 1/12 seconds.
- \* Audio can be recorded when the recording mode is 24PN/25PN/30PN and the frame rate is 24/25/30 respectively. Also, the time code can be set to free-run (F-RUN).

### Standard variable frame rate recording (pull-down recording)

#### ■ Setting example in the 720-59.94P mode

#### 1 Set the [REC FORMAT] item on the setting menu [SYSTEM SETUP] screen to [AVC-I100/60P].

For details, refer to “Setting menu basic operations” (page 116).

- It can also be set on the [CAM03:SETUP] screen of SmartUI
- The frame rate can be selected from 1 frame (1P) to 60 frames (60P).

#### 2 Set the [VFR] item on the setting menu [SCENE FILE] screen to [ON], and set the [FRAME RATE] item to match your specific shooting requirement.

#### 3 Press the <REC> button.

Recording is performed in the variable frame rate mode (Over60P).

AVC-I 100/60P, AVC-I 50/60P and DVCPRO HD/60P can be selected as the recording format.

For details, refer to “List of recording/playback and output formats” (page 49), “[SYSTEM SETUP] screen” (page 122).

If the frame rate is set to a low value and a fast-moving subject is shot at 60P, the image will look as if it is flowing when it is played back to create an interesting visual effect.

### NOTE

- When the active frames are extracted by the frame rate converter, and overcrank or undercrank is set, audio can no longer be played back.
- Note the following when recording in the standard variable frame rate mode:
  - During recording, the P2 card to record to cannot be switched.
  - Pre-recording, loop recording, interval recording, one-shot recording, and one-clip recording are not possible.
  - During recording, [ON]/[OFF] setting of the [VFR] item does not change even by switching the scene file number.
  - Audio is recorded.
  - If the exposure time acquired by operating the frame rate and shutter is 1/12 seconds or longer, images are clipped at the upper limit of the brightness level when the exposure time is 1/12 seconds.

### Using the variable frame rate recording function

#### Standard-speed shooting for film production

With productions intended for showing on screen, the 24 fps (24 frames/second) frame rate the same as film screening is regularly used (1x speed). The same playback as film screening can be achieved by setting as follows. Film like video can be achieved by progressive shooting and CINE-LIKE Gamma.

■ Standard settings for film production

| Setting                       |                             | Recording frame rate                                 |
|-------------------------------|-----------------------------|--|
| [SYSTEM MODE]                 | Other item settings         |  |
| [720-59.94P]                  | [REC FORMAT]                | [AVC-I100/24PN]<br>[AVC-I50/24PN]<br>[DVCPROHD/24PN] |
|                               | [VFR]                       | [OFF]  |
| [1080-59.94i]                 | [REC FORMAT]                | [AVC-I100/24PN]<br>[AVC-I50/24PN]<br>[DVCPROHD/60i]  |
|                               | [CAMERA MODE]* <sup>1</sup> | [24P]  |
| [1080-23.98PsF]* <sup>2</sup> | [REC FORMAT]                | [AVC-I100/24PN]<br>[AVC-I50/24PN]                    |

\*<sup>1</sup> Only when the [REC FORMAT] item on the setting menu [SYSTEM SETUP] screen is set to [DVCPROHD/60i]

\*<sup>2</sup> Can be selected by installing the production pack (extra-cost option).

**Normal speed shooting for commercials/drama production**

With productions intended for screening on TV screen such as HDTV/SDTV broadcasts, a 30 fps (30 frames/second) or 25 fps (25 frames/second) frame rate is regularly used (i.e. 1x speed). The same playback as a broadcasting station can be achieved by setting as follows. Commercials and music videos can be recorded as film like video and, moreover, at number of frames/second ideal for TV broadcasts.

■ Standard settings for CM/drama production

| Setting       |                     | Recording frame rate                                 |
|---------------|---------------------|--|
| [SYSTEM MODE] | Other item settings |  |
| [720-59.94P]  | [REC FORMAT]        | [AVC-I100/30PN]<br>[AVC-I50/30PN]<br>[DVCPROHD/30PN] |
|               | [VFR]               | [OFF]  |
| [1080-59.94i] | [REC FORMAT]        | [AVC-I100/30PN]<br>[AVC-I50/30PN]<br>[DVCPROHD/60i]  |
|               | [CAMERA MODE]*      | [30P]  |
| [720-50P]     | [REC FORMAT]        | [AVC-I100/25PN]<br>[AVC-I50/25PN]<br>[DVCPROHD/25PN] |
|               | [VFR]               | [OFF]  |
| [1080-50i]    | [REC FORMAT]        | [AVC-I100/25PN]<br>[AVC-I50/25PN]<br>[DVCPROHD/50i]  |
|               | [CAMERA MODE]*      | [25P]  |

\* Only when the [REC FORMAT] item on the setting menu [SYSTEM SETUP] screen is set to [DVCPROHD/60i] or [DVCPROHD/50i]

**Undercrank shooting**

This is a quick motion effect that can be applied to scenes showing the flow of clouds, people standing in the middle of crowds, and kung fu, etc. For example, when shooting in recording format 24P for specifying the playback frame, a 2x speed quick motion effect can be obtained by setting the variable frame rate to 12 fps.

■ Standard settings for undercrank shooting

| Setting       |  |       |                           | Recording frame rate |
|---------------|--|-------|---------------------------|----------------------|
| [SYSTEM MODE] | [REC FORMAT]   | [VFR] | [FRAME RATE]              |                      |
| [720-59.94P]  | [AVC-I100/24PN]<br>[AVC-I50/24PN]<br>[DVCPROHD/24PN] | [ON]  | Set to [22FRAME] or less. | 1 to 22 frames       |
| [1080-59.94i] | [AVC-I100/24PN]<br>[AVC-I50/24PN]                    |       |                           |                      |
| [720-50P]     | [AVC-I100/25PN]<br>[AVC-I50/25PN]<br>[DVCPROHD/25PN] | [ON]  | Set to [24FRAME] or less. | 1 to 24 frames       |
| [1080-50i]    | [AVC-I100/25PN]<br>[AVC-I50/25PN]                    |       |                           |                      |

• Even if recording is not performed in the Native recording mode, Quick motion effects can be obtained by processing recorded video on a nonlinear editing system.

• [VFR] cannot be set if [SYSTEM MODE] is set to [1080-23.98PsF].

### Overcrank shooting

This is a slow motion effect that can be applied to scenes such as car chases, action, climaxes, etc. For example, when recording in recording format 24P for specifying the playback frame, a 2.5x speed slow motion effect can be obtained by setting the recording frame rate to 60 fps. 720P progressive images are smooth and provide a high-quality slow motion effect.

#### ■ Standard settings for overcrank shooting

| Setting       |  |       |                           | Recording frame rate |
|---------------|--|-------|---------------------------|----------------------|
| [SYSTEM MODE] | [REC FORMAT]   | [VFR] | [FRAME RATE]              |                      |
| [720-59.94P]  | [AVC-I100/24PN]<br>[AVC-I50/24PN]<br>[DVCPROHD/24PN] | [ON]  | Set to [25FRAME] or more. | 25 to 60 frames      |
| [1080-59.94i] | [AVC-I100/24PN]<br>[AVC-I50/24PN]                    |       |                           | 25 to 30 frames      |
| [720-50P]     | [AVC-I100/25PN]<br>[AVC-I50/25PN]<br>[DVCPROHD/25PN] | [ON]  | Set to [26FRAME] or more. | 26 to 50 frames      |

- Even if recording is not performed in the Native recording mode, slow motion effects can be obtained by processing recorded video on a nonlinear recording system.
- [VFR] cannot be set if [SYSTEM MODE] is set to [1080-23.98PsF].



## Special recording functions

When recording to P2 cards, the special recording functions of pre-recording, interval recording, one-shot recording, loop recording, and one-clip recording can be performed by setting on the setting menu [RECORDING SETUP] screen.

Pre-recording and one-clip recording can be performed in all recording modes, excluding when [VFR] is set to [ON].

Interval recording, one-shot recording and loop recording can be used only in the following setting combinations.

| [SYSTEM MODE] | [REC FORMAT]                                      | [CAMERA MODE]  | [VFR] |
|---------------|---|----------------|-------|
| [1080-59.94i] | [AVC-I100/60i]<br>[AVC-I50/60i]                   | —              | [OFF] |
|               | [DVCPROHD/60i]                                    | [60i] or [30P] |       |
| [720-59.94P]  | [DVCPROHD/60P]<br>[AVC-I100/60P]<br>[AVC-I50/60P] | —              |       |
| [480-59.94i]  | [DVCPRO50/60i]<br>[DVCPRO/60i]<br>[DV/60i]        | [60i] or [30P] | —     |
| [1080-50i]    | [AVC-I100/50i]<br>[AVC-I50/50i]<br>[DVCPROHD/50i] | —              | [OFF] |
| [720-50P]     | [DVCPROHD/50P]<br>[AVC-I100/50P]<br>[AVC-I50/50P] | —              |       |
| [576-50i]     | [DVCPRO50/50i]<br>[DVCPRO/50i]<br>[DV/50i]        | —              | —     |

### Pre-recording

This function enables recording of video and audio from a fixed amount of time (approx. three seconds in HD recording and approx. seven seconds in SD recording) before recording is actually started.

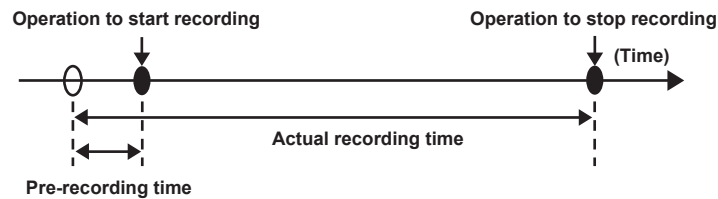

#### 1 Check the settings for each item on the setting menu [SYSTEM SETUP] screen.

For details, refer to “Special recording functions” (page 41).

For details on menu operations, refer to “Setting menu basic operations” (page 116).

#### 2 Set the [PREREC MODE] item on the setting menu [RECORDING SETUP] screen to [ON].

The following is displayed in the special recording display area of the viewfinder screen (page 75):

|                       |                     |
|-----------------------|---------------------|
| Recording in progress | P-REC illuminated   |
| Paused                | P-PAUSE illuminated |

#### 3 Press the <REC> button.

Video and audio from the fixed amount of time is recorded,

- In the following instances, pre-recording is invalid and recording begins from the moment that each operation is performed:

- When the recording format is switched
- When playback moves to recording
- At interval recording
- At one-shot recording
- At loop recording

- Video and audio from the specific amount of time cannot be recorded even if recording is started immediately after the thumbnail display or playback is switched to camera video, the power is turned on, or the [PREREC MODE] item is changed.

### Interval recording

This function enables recording of single frames at the time interval set at the [INTERVAL TIME] item.

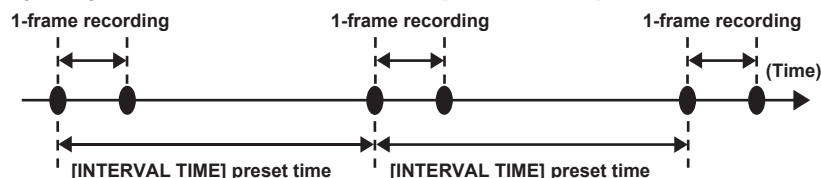

#### 1 Check the settings for each item on the setting menu [SYSTEM SETUP] screen.

For details, refer to “Special recording functions” (page 41).

For details on menu operations, refer to “Setting menu basic operations” (page 116).

#### 2 Set the [REC FUNCTION] item on the setting menu [RECORDING SETUP] screen to [INTERVAL].

#### 3 Set the time at the [INTERVAL TIME] item on the setting menu [RECORDING SETUP] screen.

#### 4 Press the <REC> button.

- The single-frame recording operation is repeated at the time interval set at the [INTERVAL TIME] item.

- To stop recording, press the <HOME> button to display the [HOME] screen of SmartUI, and press the <STOP> button.  
Recording cannot be stopped on screens other than [HOME], because the function other than stop function is assigned to the <STOP> button.
- To clear settings, either turn off the power or set to [NORMAL] at the setting menu [REC FUNCTION] item.
- The setting should be as follows at the left of the operating mode display:
  - Recording: I-REC illuminated

- Paused: I-PAUSE illuminated  
Note, however, that when the setting in step 3 is less than two seconds, recording in progress I-REC flashes according to the preset time.
- Stopped: I- of I-PAUSE flashing

**NOTE**

- The pre-recording and one-clip recording are disabled.
- Audio is not recorded.
- Data recorded in this mode (data until the <STOP> button is pressed) is grouped together into a single file.

**One-shot recording**

This function performs recording once only for the preset time.

**1 Check the settings for each item on the setting menu [SYSTEM SETUP] screen.**

For details, refer to “Special recording functions” (page 41).  
For details on menu operations, refer to “Setting menu basic operations” (page 116).

**2 Set the [REC FUNCTION] item on the setting menu [RECORDING SETUP] screen to [ONE SHOT].**

**3 Set the time at the [ONE SHOT TIME] item on the setting menu [RECORDING SETUP] screen.**

**4 Press the <REC> button.**

- Recording is performed for the time preset in step 3, after which recording is paused.
- To stop recording, press the <HOME> button to display the [HOME] screen of SmartUI, and press the <STOP> button.  
Recording cannot be stopped on screens other than [HOME], because the function other than stop function is assigned to the <STOP> button.

- To clear settings, either turn off the power or set to [NORMAL] at the setting menu [REC FUNCTION] item.
- The setting should be as follows at the left of the operating mode display:
  - Recording: I-REC illuminated
  - Paused: I-PAUSE illuminated
  - Stopped: I- of I-PAUSE flashing

**NOTE**

- While this function is enabled, other operations are not accepted.
- The pre-recording and one-clip recording are disabled.
- Audio is not recorded.
- Data recorded in this mode (data until the <STOP> button is pressed) is grouped together into a single file.
- Acceptance of other recording operations sometimes slows down when recording is continued by one-shot recording.

**Loop recording**

- This function successively records to two P2 cards inserted in the P2 card slots.
  - When there is no more free space on the card, recording returns to the first card, and recording is continued while erasing existing data already saved on that card.
- For details, refer to “Dividing clips recorded on P2 cards” (page 34).

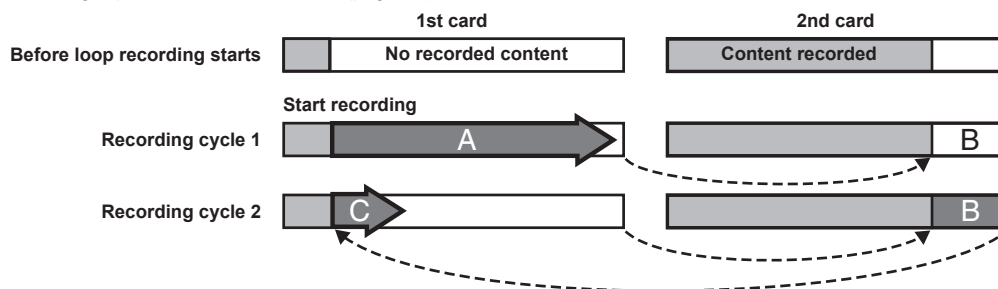

**1 Check the settings for each item on the setting menu [SYSTEM SETUP] screen.**

For details, refer to “Special recording functions” (page 41).  
For details on menu operations, refer to “Setting menu basic operations” (page 116).

**2 Set the [REC FUNCTION] item on the setting menu [RECORDING SETUP] screen to [LOOP].**

**3 Press the <REC> button.**

- Recording is started.
- To stop recording, press the <REC> button.
- To clear settings, either turn off the power or set to [NORMAL] at the setting menu [REC FUNCTION] item.
- The setting should be as follows at the left of the operating mode display:
  - Recording: L-REC illuminated
  - Stopped: L-PAUSE illuminated
  - Little free space left: P2 LACK L- flashing

**NOTE**

- When this function is used, each P2 card must have at least one minute of free space.
- When the mode check screen is switched to, the standard recording time in accordance with the recording format is displayed as the P2 card remaining space. When loop recording is stopped immediately after an old recording is erased, the time recorded on the card is sometimes less than the indicated time.
- The pre-recording and one-clip recording are disabled.
- It may take time for recording to stop. The subsequent operation is not accepted until the P2 card access LED stops flashing and stays illuminated.
- During loop recording, all P2 card access LEDs on the P2 cards used for recording are illuminated or flash orange. Note that loop recording stops when these P2 cards are removed.
- Loop recording may stop when the input reference signal of the generator lock is disrupted during loop recording.

### One-clip recording

This function allows multiple recordings into a combined clip and does not isolate single recording (from recording start to stop).

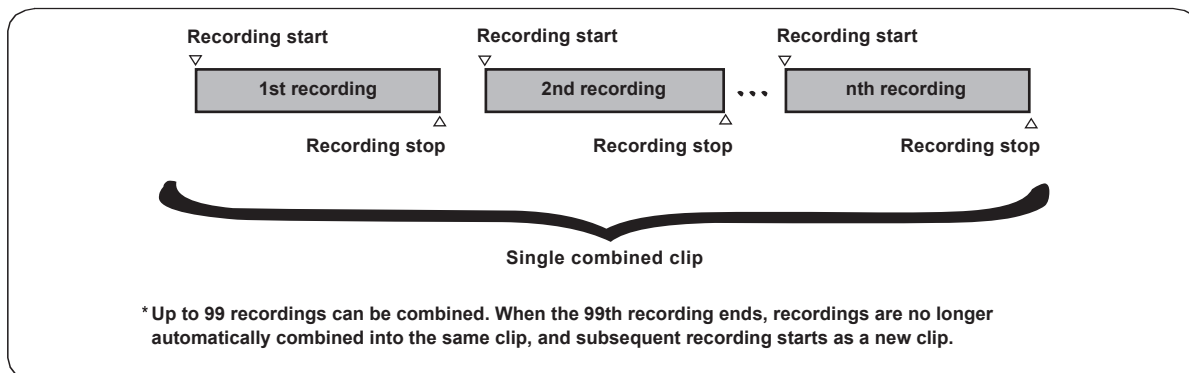

To use this function, set the [ONE CLIP REC] item on the [RECORDING SETUP] screen to [ON] by menu operations.

When the one-clip recording mode is selected, [1-CLIP] is displayed at the top of the viewfinder screen.

Pressing the <REC> button on the camera starts the first recording, and [START\*1CLIP] is displayed.

Subsequent recordings are automatically combined into the clip. Up to 99 recordings can be combined into a single clip.

### Recording a new clip

Follow the instructions below to use a new and separate clip, and end combining to the clip.

- While recording is paused, press the <HOME> button to display the [HOME] screen on SmartUI, and press the <STOP> button for two seconds or longer. (When operating while recording is on standby)

On screens other than [HOME], the function other than stop function is assigned to the <STOP> button.

- Press and hold the <REC> button for approximately two seconds during recording to end recording. (When operating during recording)

Follow the instructions above to end combining to the clip. [END 1-CLIP] is displayed, and subsequent recordings are made to a new and separate clip.

### NOTE

- In addition to the above steps, recordings are no longer automatically combined into the same clip and subsequent recording are combined into a new clip in the following instances:
  - When the power is turned off
  - When the P2 card with the previous recording is removed
  - When the P2 card is formatted or the clip is deleted (when the previous combined clip does not exist)
- Combining to a clip does not end even by pressing the <STOP> button in the menu or in the thumbnail display.
- Combining to a clip cannot be stopped even by pressing the <STOP> or <REC> button on the remote control unit (AJ-RC10G) and on the extension control unit (AG-EC4G).

### Exiting the one-clip recording mode

Set the [ONE CLIP REC] item to [OFF] by menu operations.

### Cueing to the start of the combined section of a clip

A text memo can be automatically attached to the start of the recording, the start of a section can be cued for playback, and the thumbnail of the location can be checked before each recording.

To automatically attach a text memo at the start of recording, set the [START TEXT MEMO] item on the [RECORDING SETUP] screen to [ON] by menu operations.

To check and play back the location of the attached text memo, select [THUMBNAIL] menu → [TEXT MEMO CLIPS] or [SHOOT INFO] from the thumbnail menu and move the cursor over the desired clip.

For details, refer to “Playing back from the text memo position” (page 106).

Also, to cue the location of the text memo for playback, set the [SEEK SELECT] item on the [OTHER FUNCTIONS] screen to [CLIP&T], and press the <FF/▶▶> or <◀◀/REW> button while playback is paused.

### Proxy recording (extra-cost option) in the one-clip recording mode

Proxy recording is possible even in the one-clip recording mode.

Since proxy data is also grouped together in the same way as a combined clip, it can be handled as a single clip in P2 Viewer Plus, for example.

However, note the following when recording the proxy data to SD memory cards.

- When the SD memory card is removed and replaced while combining of clips is in progress, proxy recording is not performed to the SD memory card until combining of subsequent clips ends. Check available space and the number of the files (maximum 1000 clips) before using the card. To continue proxy recording after the SD memory card has been replaced midway, hold down the <STOP> button for approximately two seconds to end combining of clips and start recording as a new clip.
- The proxy data on the SD memory card to which recording was stopped midway will not match the data of the clip recorded on the P2 card and will be incomplete.

### Notes on the one-clip recording mode

- The one-clip recording mode is disabled when interval recording, one-shot recording, loop recording, and variable frame rate recording functions are selected.

- Menu and thumbnail operations are restricted as follows when combining to the clip is in progress. Press the <STOP> button for approximately two seconds to stop combining to the clip, and try the operations again.
  - The following setting menus cannot be changed.  
[SYSTEM MODE], [REC SIGNAL], [CAMERA MODE], [REC FORMAT], [PC MODE], [REC FUNCTION], [25M REC CH SEL]

 **NOTE**

- The [VFR] item can be changed to “ON” by the jog dial or menu even while combining to the clip is in progress. In this case, combining of the clip ends, and subsequent recordings are made to separate clips each time.
- The following menu items relating to reading/writing of the SD memory card and reading of setting files cannot be executed:
  - [LOAD/SAVE/INIT] item on the [SCENE FILE] screen
  - Each item on the [CARD FUNCTIONS] screen
  - [CAC CARD READ] item on the [LENS SETUP] screen
  - [USER FILE] and [MENU INIT] items on the [OTHER FUNCTIONS] screen
- The following thumbnail menu items cannot be selected and executed:  
[OPERATION] → [COPY]
- To enable combining of the clip at the next recording, end processing of recording may take slightly longer than standard recording.
- Fade processing on non-continuous audio is not made at combining of recordings in clips at playback.
- When clips containing many clip combinations are used in nonlinear editing software, operation of the clip may not be normal depending of the type of software. (As of September, 2014)  
For the latest information on software whose operation has been verified, visit the support desk at the following website:  
<http://pro-av.panasonic.net/>

**Proxy recording function (extra-cost option)**

By installing the video encoder board (extra-cost option), video recordings in MPEG4 or H.264 format and real-time data such as time code data can be recorded to the P2 card and SD memory card simultaneously in addition to the video and audio of the materials recorded on the camera. For details, refer to “Video encoder board (AG-YDX600G)” (page 162).

**Hot swap recording**

When P2 cards are inserted into two P2 card slots, recording can be performed continuously across two cards.

Also, the card other than the one currently being recorded to can be swapped and recording can be continued on two or more cards. (hot swap recording function)

Note, however, P2 card recognition might slow down depending on the timing (immediately after pre-recording or before and after continuous recording across two card slots) that the P2 card is inserted into the vacant card slot. When inserting a P2 card, make sure that there is at least one minute of free space on the card to be recorded to.

 **NOTE**

- Hot swap playback is not supported.

**Rec review function**

- After recording ends, pressing the <RET> button on the lens automatically cues to approximately the last two seconds of video just recorded. The playback time can be increased up to ten seconds by holding down the <RET> button on the lens.  
In this way, you can check whether or not video has been recorded properly. After playback, the camera is again ready to start recording. For short clips, however, when the start of the clip is cued to, holding down the <RET> button does not play back any clips before the current clip.
- The rec review function can be assigned to each of the <USER> buttons (<USER MAIN>/<USER1>/<USER2>) at the [USER MAIN], [USER1], and [USER2] items on the setting menu [SW MODE] screen.

 **NOTE**

- Note that when a backup device is connected to the <SDI OUT/IN (OP)> terminal, etc., and the backup image is being recorded, the playback image currently in use by the recording review function will be recorded.
- In the one-clip recording mode, the furthest rewind point using rec review and the playback start point after pausing recording is not at the start of the clip, but at the start of the most recent recording.

**Shot mark recording function**

Shot mark is the mark added to the thumbnail of each clip to distinguish that clip from others.

Only clips with shot marks attached can be displayed or played back.

**Adding shot marks**

**1 Assign shot marks to the desired <USER> buttons (<USER MAIN>/<USER1>/<USER2>) or the <RET> button on the lens on the setting menu [SW MODE] screen.**

For details, refer to “Setting menu basic operations” (page 116).

**2 During recording or a pause after recording, press the button to which the shot mark is assigned (the <USER> buttons (<USER MAIN>/<USER1>/<USER2>) or the <RET> button on the lens).**

- [SHOT MARK ON] is displayed, and the shot mark is added to the clip currently being recorded.

- Another press of the button displays [SHOT MARK OFF] and the shot mark disappears.

 **NOTE**

- When the shot mark is added during a recording pause, it is added to the clip recorded immediately before.
- Shot marks can also be added while the thumbnail display is active.
- Shot marks cannot be added in loop recording, interval recording and one-shot recording. If an operation is invalid, [SHOT MARK INVALID] is displayed when the button is pressed.

- During playback, setting or canceling the shot mark is not available, but while pausing the playback, setting or canceling the shot mark is available.
- When video data obtained by a single shooting session by hot swap recording comprises multiple clips, the shot mark can be set or deleted only if all P2 cards containing that video data are inserted in the card slots. Also, with video data comprising multiple clips like this, the shot mark can be added to the top clip only.

### Text memo recording function

Text memos can be added to any video point while a clip is being recorded or played back.

Only clips with a text memo added can be selected and displayed as thumbnails, thumbnails and time codes at text memo positions can be displayed and played back from text memo points, and only required positions can be selected and copied. (page 105)

### Adding text memos

- 1 Assign text memos to the desired <USER> buttons (<USER MAIN>/<USER1>/<USER2>) or the <RET> button on the lens on the setting menu [SW MODE] screen.**

For details, refer to “Setting menu basic operations” (page 116).

- 2 During recording or a pause after recording, press the button to which the text memo is assigned (the <USER> buttons (<USER MAIN>/<USER1>/<USER2>) or the <RET> button on the lens).**

[TEXT MEMO] is displayed, and the text memo is added to the video clip that was displayed when the button was pressed.



#### NOTE

- Up to 100 text memos can be recorded to a single clip.
- Text memos cannot be added in loop recording, interval recording and one-shot recording. If an operation is invalid, [TEXT MEMO INVALID] is displayed when the button is pressed.

## Normal and variable speed playback

---

### ■ Normal speed playback

Color playback images can be viewed on the viewfinder screen by pressing the <PLAY/PAUSE> button. Likewise, color playback images can be viewed on a color video monitor connected to the <MON OUT>, <SDI OUT/IN (OP)>, or <HDMI> terminal.

Playback can also be paused by pressing the <PLAY/PAUSE> button during playback.

### ■ Fast-forward and fast-reverse playback

The <FF/▶▶▶> and <◀◀◀/REW> buttons provide 32x and 4x fast-forward and fast-reverse playback. Pressing these buttons during a stop and playback fast-forwards and fast-reverses at 32x and 4x speed, respectively.

### ■ Cueing clips

If the <FF/▶▶▶> button is pressed with playback paused, the clip being played back is paused at the start point of the next clip (cued state). If the <◀◀◀/REW> button is pressed with playback paused, the clip being played back is paused at the start point of the clip currently being played back (cued state).

### NOTE

- When playing back or switching to the thumbnail screen immediately after removing or inserting the P2 card or the power is turned on, it may take time to read the clip information. During this time, [UPDATING..] is displayed on the thumbnail screen.
- If a P2 card is inserted while another card is being played back, the clips on the inserted card cannot be played back. A P2 card inserted during playback is recognized after playback ends.
- When playing back clips spread over multiple P2 cards at variable speed, audio might be instantaneously interrupted, though this is not a malfunction.
- To play back clips in the different system mode, match the [SYSTEM MODE] item to the format of the clip and set the camera again.
- Audio of CH5 to CH8 recorded on another device cannot be played back.

## Chapter 4 **Adjustments and Settings for Recording**

---

This chapter describes how to set convenient functions such as adjusting white and black balance, adjusting shooting functions such as flash band compensation (FBC) function, assigning functions to the <USER> buttons (<USER MAIN>/<USER1>/<USER2>), and setting the time data.

## Multi formats

### Selecting recording signals

The camera records images in the format of HD (1080i, 720P) signals combining the AVC-Intra or DVCPRO HD codecs, and SD (480i/576i) signals combining the DVCPRO50, DVCPRO, and DV codecs respectively.

Various shooting frames and recording frames (native recording) can be selected according to your specific requirements.

You can select recording and shooting signals in the following setting menus.

| Setting menu screen   | Setting menu item | Description of settings   |
|-----------------------|-------------------|---|
| [SYSTEM SETUP] screen | [SYSTEM MODE]     | Select the 1080i/720P/480i/576i signal format.<br>When this setting is changed, wait until [TURN POWER OFF] is displayed, and turn off the power then back on again.  |
|                       | [REC SIGNAL]      | Can be switched between recording of shooting with the camera [CAMERA] and input recording of the SDI signal [SDI IN] by installing the HD/SD SDI input board (extra-cost option).  |
|                       | [REC FORMAT]      | Select the codec of AVC-Intra or DVCPRO HD in the HD mode, and select each codec of DVCPRO50, DVCPRO, and DV in the SD mode. Set the shooting frame rate at the same time.  |
|                       | [CAMERA MODE]     | Select the pull-down shooting mode when not in the native recording.  |
|                       | [ASPECT CONV]     | In the SD mode, select the video aspect ratio for recording and output.   |
| [SCENE FILE] screen   | [VFR]             | Can be switched by installing the production pack (extra-cost option). When is set to [ON], shooting by the variable frame rate recording function is possible, and shooting and recording can be performed according to the shooting frame rate setting of the [FRAME RATE] item.<br>For details, refer to "Variable frame rate (VFR) recording function (extra-cost option)" (page 38). |
|                       | [FRAME RATE]      | Can be switched by installing the production pack (extra-cost option). Set the number of frames for variable frame rate shooting when the [VFR] item is set to [ON].  |

### NOTE

- When the [SYSTEM MODE], [REC SIGNAL], [REC FORMAT], or [CAMERA MODE] item is changed, video or audio may be interrupted, but this is not a malfunction.

### Recording formats and recording playback times

The table below shows the recording formats and recording playback times supported by the camera.

| Capacity |         | Recording format |                 |                 |                 |                 |
|----------|---------|------------------|-----------------|-----------------|-----------------|-----------------|
|          |         | AVC-Intra 100    | AVC-Intra 50    | DVCPRO HD       | DVCPRO50        | DVCPRO/DV       |
| 64 GB    | 1 card  | Approx. 64 min   | Approx. 128 min | Approx. 64 min  | Approx. 128 min | Approx. 256 min |
|          | 2 cards | Approx. 128 min  | Approx. 256 min | Approx. 128 min | Approx. 256 min | Approx. 512 min |
| 32 GB    | 1 card  | Approx. 32 min   | Approx. 64 min  | Approx. 32 min  | Approx. 64 min  | Approx. 128 min |
|          | 2 cards | Approx. 64 min   | Approx. 128 min | Approx. 64 min  | Approx. 128 min | Approx. 256 min |
| 16 GB    | 1 card  | Approx. 16 min   | Approx. 32 min  | Approx. 16 min  | Approx. 32 min  | Approx. 64 min  |
|          | 2 cards | Approx. 32 min   | Approx. 64 min  | Approx. 32 min  | Approx. 64 min  | Approx. 128 min |

- Recording playback time becomes 1.25 times longer in 24PN native recording.
- The above times were obtained by continuous recording as a single clip. The overall recording time might be shorter than the times above depending on the number of clips to record.

### List of recording settings and recording functions

The recording modes of the camera act as follows depending on the menu settings.

| Setting                            | Recording setting (setting menu) |                |          |                                   | Recording/operation enabled/disabled |                    |                 |               |               |
|------------------------------------|----------------------------------|----------------|----------|-----------------------------------|--------------------------------------|--------------------|-----------------|---------------|---------------|
|                                    | [REC SIGNAL]                     | [REC FUNCTION] | [VFR]*1  | [REC FORMAT]                      | Pre-recording                        | One-clip recording | Proxy*1         | Text memo     | Shot mark     |
| Interval recording                 | [CAMERA]                         | [INTERVAL]     | Disabled | Disabled                          | Not available                        | Not available      | Not available   | Not available | Not available |
| One-shot recording                 |                                  | [ONE SHOT]     |          |                                   |                                      |                    |                 |               |               |
| Loop recording                     |                                  | [LOOP]         |          |                                   |                                      |                    |                 |               |               |
| Native variable frame rate (VFR)   |                                  | [NORMAL]       | [ON]     | [24PN], [30PN], [25PN]            | Not available*2                      | Not available*2    | Not available*2 | Available     | Available     |
| Standard variable frame rate (VFR) |                                  |                |          | Other than [24PN], [30PN], [25PN] | Not available                        | Not available      | Not available   |               |               |
| Standard recording                 |                                  |                | [OFF]    | All formats                       | Available                            | Available          | Available       |               |               |
| Input recording of SDI signal      | [SDI IN]                         | Disabled       | Disabled | [60i], [50i], [60P], [50P]        | Not available                        | Not available      | Available       |               |               |

\*1 This becomes valid when the production pack (extra-cost option) is installed.

\*2 This becomes valid when the frame rates of [REC FORMAT] and [VFR] are the same.



**Selecting video output**

The video output method can be selected.

Video output can be selected, for example, in the following setting menus.

| Setting menu item                                      | Description of settings  |
|--|--|
| [MON]<br>([SET02:MON/HDMI FORMAT] screen of SmartUI)   | Select the signal method used to output to the <MON OUT> and <HDMI> terminals.   |
| [SETUP]<br>([SYSTEM SETUP] screen)                     | Select the setup level of the signal (composite) to output to the <MON OUT> terminal.<br>• [0%]: 0% setup for both output and recording<br>• [7.5%A]: 7.5% setup for output only (recording 0%)<br>The [SETUP] menu setting is valid at playback, too. |
| [D.CON]<br>([SET02:MON/HDMI FORMAT] screen of SmartUI) | Select the screen type at down conversion output (composite and SD SDI output) in the HD mode (1080i, 720P).   |

**Selecting video output from each terminal**

| [SYSTEM MODE]                          | Monitor output setting<br>([SET02:MON/HDMI<br>FORMAT] screen of<br>SmartUI)* |              | Video output               |                      |                 |
|--|--|--------------|----------------------------|----------------------|-----------------|
|  | [MON]  | [HDMI]       | <SDI OUT/IN (OP)> terminal | <MON OUT> terminal   | <HDMI> terminal |
| [1080-59.94i]                          | [AUTO]   | [1080i/720P] | 1080/59.94i                | 1080/59.94i (HD SDI) | 1080/59.94i     |
|  | [480i]   | [480P]       |                            | 480/59.94i (SD SDI)  | 480/59.94p      |
|  | [VBS]  | [480P]       |                            | 480/59.94i (VBS)     | 480/59.94p      |
| [1080-23.98PsF]<br>(extra-cost option) | [AUTO]   | [1080i/720P] | 1080-23.98PsF              | 1080/59.94i (HD SDI) | 1080/59.94i     |
|  | [480i]   | [480P]       |                            | 480/59.94i (SD SDI)  | 480/59.94p      |
|  | [VBS]  | [480P]       |                            | 480/59.94i (VBS)     | 480/59.94p      |
| [720-59.94P]                           | [AUTO]   | [1080i/720P] | 720/59.94p                 | 720/59.94p (HD SDI)  | 720/59.94p      |
|  | [480i]   | [480P]       |                            | 480/59.94i (SD SDI)  | 480/59.94p      |
|  | [VBS]  | [480P]       |                            | 480/59.94i (VBS)     | 480/59.94p      |
| [480-59.94i]                           | [SDI]  | [480P]       | 480/59.94i                 | 480/59.94i (SD SDI)  | 480/59.94p      |
|  | [VBS]  | [480P]       |                            | 480/59.94i (VBS)     | 480/59.94p      |
| [1080-50i]                             | [AUTO]   | [1080i/720P] | 1080/50i                   | 1080/50i (HD SDI)    | 1080/50i        |
|  | [576i]   | [576P]       |                            | 576/50i (SD SDI)     | 576/50p         |
|  | [VBS]  | [576P]       |                            | 576/50i (VBS)        | 576/50p         |
| [720-50P]                              | [AUTO]   | [1080i/720P] | 720/50p                    | 720/50p (HD SDI)     | 720/50p         |
|  | [576i]   | [576P]       |                            | 576/50i (SD SDI)     | 576/50p         |
|  | [VBS]  | [576P]       |                            | 576/50i (VBS)        | 576/50p         |
| [576-50i]                              | [SDI]  | [576P]       | 576/50i                    | 576/50i (SD SDI)     | 576/50p         |
|  | [VBS]  | [576P]       |                            | 576/50i (VBS)        | 576/50p         |

\* The [MON] item and the [HDMI] item are interlocked.

**List of recording/playback and output formats**
**■ Camera recording mode (when the [REC SIGNAL] item is [CAMERA])**

| Setting ([SYSTEM MODE] = [1080-59.94i]) |               |       |              | Recording format                       |                         | <SDI OUT/IN (OP)> terminal          |       |
|---|---------------|-------|--------------|--|-------------------------|-------------------------------------|-------|
| [REC FORMAT]                            | [CAMERA MODE] | [VFR] | [FRAME RATE] |  |                         | Video format                        | Audio |
| [AVC-I100/60i]<br>[AVC-I50/60i]         | Disabled      | [OFF] | Disabled     | 1080/60i                               | AVC-I 100<br>(AVC-I 50) | 1080-59.94i                         | 4ch   |
| [AVC-I100/30PN]<br>[AVC-I50/30PN]       |               |       |              | 1080/30PN Native                       |                         | 1080-29.97PsF<br>Over59.94i 2:2     |       |
| [AVC-I100/24PN]<br>[AVC-I50/24PN]       |               |       |              | 1080/24PN Native                       |                         | 1080-23.98PsF<br>Over59.94i 2:3     |       |
| [DVCPROHD/60i]                          | [60i]         | [OFF] | Disabled     | 1080/60i                               | DVCPRO HD               | 1080-59.94i                         | 4ch   |
|   | [30P]         |       |              | 1080/30P Over60i 2:2 Pull<br>Down      |                         | 1080-29.97PsF<br>Over59.94i 2:2     |       |
|   | [24P]         |       |              | 1080/24P Over60i 2:3 Pull<br>Down      |                         | 1080-23.98PsF<br>Over59.94i 2:3     |       |
|   | [24PA]        |       |              | 1080/24PA Over60i 2:3:3:2<br>Pull Down |                         | 1080-23.98PsF<br>Over59.94i 2:3:3:2 |       |

Chapter 4 Adjustments and Settings for Recording — Multi formats

| Setting ([SYSTEM MODE] = [1080-59.94i]) |               |       |              | Recording format   |                         | <SDI OUT/IN (OP)> terminal |                                 |
|---|---------------|-------|--------------|--|-------------------------|----------------------------|---------------------------------|
| [REC FORMAT]                            | [CAMERA MODE] | [VFR] | [FRAME RATE] |  |                         | Video format               | Audio                           |
| [AVC-I100/60i]<br>[AVC-I50/60i]         | Disabled      | [ON]* | [1] - [30P]  | 1080/60i   | AVC-I 100<br>(AVC-I 50) | 1080-59.94i VFR            | 4ch                             |
| [AVC-I100/30PN]<br>[AVC-I50/30PN]       |               |       |              | 1080/30PN Native VFR<br>(At 30P: 30PN Native audio recordable) |                         |                            | Mute<br>(At 30P: 4ch available) |
| [AVC-I100/24PN]<br>[AVC-I50/24PN]       |               |       |              | 1080/24PN Native VFR<br>(At 24P: 24PN Native audio recordable) |                         |                            | Mute<br>(At 24P: 4ch available) |
| [DVCPROHD/60i]                          | [60i]         |       | [1] - [30P]  | 1080/60i   | DVCPRO HD               | 1080-59.94i VFR            | 4ch                             |

• When [CAMERA MODE] is set to [30P], [24P], or [24PA], [VFR] is set to [OFF].

| Setting ([SYSTEM MODE] = [1080-50i]) |                |       |              | Recording format   |                         | <SDI OUT/IN (OP)> terminal         |                                 |
|--------------------------------------|----------------|-------|--------------|--|-------------------------|------------------------------------|---------------------------------|
| [REC FORMAT]                         | [CAMERA MODE]  | [VFR] | [FRAME RATE] |  |                         | Video format                       | Audio                           |
| [AVC-I100/50i]<br>[AVC-I50/50i]      | Disabled       | [OFF] | Disabled     | 1080/50i   | AVC-I 100<br>(AVC-I 50) | 1080-50i                           | 4ch                             |
| [AVC-I100/25PN]<br>[AVC-I50/25PN]    |                |       |              | 1080/25PN Native   |                         | 1080-25PsF Over50i 2:2             |                                 |
| [DVCPROHD/50i]                       | [50i]<br>[25P] |       |              | 1080/50i<br>1080/25P Over50i 2:2 Pull Down                     | DVCPRO HD               | 1080-50i<br>1080-25PsF Over50i 2:2 | 4ch                             |
| [AVC-I100/50i]<br>[AVC-I50/50i]      | Disabled       | [ON]* | [1] - [25P]  | 1080/50i   | AVC-I 100<br>(AVC-I 50) | 1080-50i VFR                       | 4ch                             |
| [AVC-I100/25PN]<br>[AVC-I50/25PN]    |                |       |              | 1080/24PN Native VFR<br>(At 25P: 25PN Native audio recordable) |                         |                                    | Mute<br>(At 25P: 4ch available) |
| [DVCPROHD/50i]                       | [50i]          |       | [1] - [25P]  | 1080/50i   | DVCPRO HD               | 1080-50i VFR                       | 4ch                             |

• When [CAMERA MODE] is set to [25P], [VFR] is set to [OFF].

| Setting ([SYSTEM MODE] = [1080-23.98PsF]*) |               |          |              | Recording format |                         | <SDI OUT/IN (OP)> terminal   |       |
|--|---------------|----------|--------------|------------------|-------------------------|------------------------------|-------|
| [REC FORMAT]                               | [CAMERA MODE] | [VFR]    | [FRAME RATE] |                  |                         | Video format                 | Audio |
| [AVC-I100/24PN]<br>[AVC-I50/24PN]          | Disabled      | Disabled | Disabled     | 1080/24PN Native | AVC-I 100<br>(AVC-I 50) | 1080-23.98PsF Over47.96i 2:2 | 4ch   |

| Setting ([SYSTEM MODE] = [720-59.94P]) |               |       |              | Recording format |                              | <SDI OUT/IN (OP)> terminal |       |
|--|---------------|-------|--------------|------------------|------------------------------|----------------------------|-------|
| [REC FORMAT]                           | [CAMERA MODE] | [VFR] | [FRAME RATE] |                  |                              | Video format               | Audio |
| [AVC-I100/60P]<br>[AVC-I50/60P]        | Disabled      | [OFF] | Disabled     | 720/60P          | AVC-I 100<br>(AVC-I 50)      | 720-59.94P                 | 4ch   |
| [AVC-I100/30PN]<br>[AVC-I50/30PN]      |               |       |              | 720/30PN Native  |                              | 720-29.97P Over59.94P 2:2  | 4ch   |
| [AVC-I100/24PN]<br>[AVC-I50/24PN]      |               |       |              | 720/24PN Native  |                              | 720-23.98P Over59.94P 2:3  | 4ch   |
| [DVCPROHD/60P]                         |               |       |              | 720/60P          | 720-59.94P<br>720-59.94P VFR | 4ch                        |       |
| [DVCPROHD/30PN]                        |               |       |              | 720/30PN Native  | 720-29.97P Over59.94P 2:2    |                            |       |
| [DVCPROHD/24PN]                        |               |       |              | 720/24PN Native  | 720-23.98P Over59.94P 2:3    | 4ch                        |       |

Chapter 4 Adjustments and Settings for Recording — Multi formats

| Setting ([SYSTEM MODE] = [720-59.94P]) |   |                                 |              | Recording format   |                         | <SDI OUT/IN (OP)> terminal |                                 |
|--|---|---------------------------------|--------------|--|-------------------------|----------------------------|---------------------------------|
| [REC FORMAT]                           | [CAMERA MODE]   | [VFR]                           | [FRAME RATE] |  |                         | Video format               | Audio                           |
| [AVC-I100/60P]<br>[AVC-I50/60P]        | Disabled  | [ON]*                           | [1] - [60P]  | 720/60P VFR  | AVC-I 100<br>(AVC-I 50) | 720-59.94P VFR             | 4ch                             |
| [AVC-I100/30PN]<br>[AVC-I50/30PN]      |   |                                 |              | 720/30PN Native VFR<br>(At 30P: 30PN Native audio recordable)  |                         |                            | Mute<br>(At 30P: 4ch available) |
| [AVC-I100/24PN]<br>[AVC-I50/24PN]      |   |                                 |              | 720/24PN Native VFR<br>(At 24P: 24PN Native audio recordable)  |                         |                            | Mute<br>(At 24P: 4ch available) |
| [DVCPROHD/60P]                         |   |                                 |              | 720/60P (At 60P)<br>720/30P Over60P 2:2 Pull Down (At 30P)<br>720/24P Over60P 2:3 Pull Down (At 24P)<br>For other than above,<br>720/60P VFR | DVCPRO HD               |                            | 4ch                             |
| [DVCPROHD/30PN]                        |   |                                 |              | 720/30PN Native VFR<br>(At 30P: 30PN Native audio recordable)  |                         |                            | Mute<br>(At 30P: 4ch available) |
| [DVCPROHD/24PN]                        | 720/24PN Native VFR<br>(At 24P: 24PN Native audio recordable) | Mute<br>(At 24P: 4ch available) |              |  |                         |                            |                                 |

| Setting ([SYSTEM MODE] = [720-50P]) |               |       |              | Recording format  |  | <SDI OUT/IN (OP)> terminal |                                 |
|-------------------------------------|---------------|-------|--------------|---|--|----------------------------|---------------------------------|
| [REC FORMAT]                        | [CAMERA MODE] | [VFR] | [FRAME RATE] |   |  | Video format               | Audio                           |
| [AVC-I100/50P]<br>[AVC-I50/50P]     | Disabled      | [OFF] | Disabled     | 720/50P   | AVC-I 100<br>(AVC-I 50)  | 720-50P                    | 4ch                             |
| [AVC-I100/25PN]<br>[AVC-I50/25PN]   |               |       |              | 720/25PN Native   |  | 720-25P Over50P 2:2        |                                 |
| [DVCPROHD/50P]                      |               |       |              | DVCPRO HD   | 720/50P  | 720-50P                    |                                 |
| [DVCPROHD/25PN]                     |               |       |              |   | 720/25P Over50P 2:2 Pull Down  | 720-25P Over50P 2:2        |                                 |
| [AVC-I100/60P]<br>[AVC-I50/60P]     | Disabled      | [ON]* | [1] - [50P]  | 720/50P VFR   | AVC-I 100<br>(AVC-I 50)  | 720-50P VFR                | 4ch                             |
| [AVC-I100/25PN]<br>[AVC-I50/25PN]   |               |       |              | 720/25PN Native VFR<br>(At 25P: 25PN Native audio recordable) |  |                            | Mute<br>(At 25P: 4ch available) |
| [DVCPROHD/50P]                      |               |       |              | DVCPRO HD   | 720/50P (At 50P)<br>720/25P Over50P 2:2 Pull Down (At 25P)<br>For other than above,<br>720/50P VFR |                            | 4ch                             |
| [DVCPROHD/25PN]                     |               |       |              |   | 720/25PN Native VFR<br>(At 25P: 25PN Native audio recordable)                                      |                            | Mute<br>(At 25P: 4ch available) |

| Setting ([SYSTEM MODE] = [480-59.94i])     |               |          |              | Recording format                   |                          | <SDI OUT/IN (OP)> terminal         |            |
|--|---------------|----------|--------------|------------------------------------|--------------------------|------------------------------------|------------|
| [REC FORMAT]                               | [CAMERA MODE] | [VFR]    | [FRAME RATE] |                                    |                          | Video format                       | Audio      |
| [DVCPRO50/60i]<br>[DVCPRO/60i]<br>[DV/60i] | [60i]         | Disabled | Disabled     | 480/60i                            | DVCPRO50<br>DVCPRO<br>DV | 480-59.94i                         | 4ch or 2ch |
|  | [30P]         |          |              | 480/30P Over60i 2:2 Pull Down      |                          | 480-29.97PsF<br>Over59.94i 2:2     |            |
|  | [24P]         |          |              | 480/24P Over60i 2:3 Pull Down      |                          | 480-23.98PsF<br>Over59.94i 2:3     |            |
|  | [24PA]        |          |              | 480/24PA Over60i 2:3:3:2 Pull Down |                          | 480-23.98PsF<br>Over59.94i 2:3:3:2 |            |

| Setting ([SYSTEM MODE] = [576-50i])        |               |          |              | Recording format              |                          | <SDI OUT/IN (OP)> terminal |            |
|--|---------------|----------|--------------|-------------------------------|--------------------------|----------------------------|------------|
| [REC FORMAT]                               | [CAMERA MODE] | [VFR]    | [FRAME RATE] |                               |                          | Video format               | Audio      |
| [DVCPRO50/50i]<br>[DVCPRO/50i]<br>[DV/50i] | [50i]         | Disabled | Disabled     | 576-50i                       | DVCPRO50<br>DVCPRO<br>DV | 576-50i                    | 4ch or 2ch |
|  | [25P]         |          |              | 576/25P Over50i 2:2 Pull Down |                          | 576-25PsF Over50i 2:2      |            |

\* The variable frame rate recording function, [1080-23.98PsF] in [SYSTEM MODE] are enabled when the production pack (extra-cost option) is installed. [24P] is recorded at 23.98P, [30P] is recorded at 29.97P, [60P] and [60i] are recorded at 59.94P and 59.94i. In the native recording mode, only valid frames are recorded. With DVCPRO50, the CH4 setting is applied, and with DVCPRO and DV, [2CH] or [4CH] setting of the [25M REC CH SEL] item on the [AUDIO SETUP] screen is applied.

Chapter 4 Adjustments and Settings for Recording — Multi formats

■ SDI signal input recording mode (when the [REC SIGNAL] item is [SDI IN])

| Setting ([SYSTEM MODE] = [1080-59.94i])           |               |          |              | Recording format |                                   | <MON OUT> terminal (<SDI OUT/IN (OP)> terminal) |                   |
|---|---------------|----------|--------------|------------------|-----------------------------------|---|-------------------|
| [REC FORMAT]                                      | [CAMERA MODE] | [VFR]    | [FRAME RATE] |                  |                                   | Video format                                    | Audio             |
| [AVC-I100/60i]<br>[AVC-I50/60i]<br>[DVCPROHD/60i] | Disabled      | Disabled | Disabled     | 1080/60i         | AVC-I 100 (AVC-I 50)<br>DVCPRO HD | 1080-59.94i                                     | 4ch               |
| Setting ([SYSTEM MODE] = [1080-50i])              |               |          |              | Recording format |                                   | <MON OUT> terminal (<SDI OUT/IN (OP)> terminal) |                   |
| [REC FORMAT]                                      | [CAMERA MODE] | [VFR]    | [FRAME RATE] |                  |                                   | Video format                                    | Audio             |
| [AVC-I100/50i]<br>[AVC-I50/50i]<br>[DVCPROHD/50i] | Disabled      | Disabled | Disabled     | 1080/50i         | AVC-I 100 (AVC-I 50)<br>DVCPRO HD | 1080-50i  | 4ch               |
| Setting ([SYSTEM MODE] = [720-59.94P])            |               |          |              | Recording format |                                   | <MON OUT> terminal (<SDI OUT/IN (OP)> terminal) |                   |
| [REC FORMAT]                                      | [CAMERA MODE] | [VFR]    | [FRAME RATE] |                  |                                   | Video format                                    | Audio             |
| [AVC-I100/60P]<br>[AVC-I50/60P]<br>[DVCPROHD/60P] | Disabled      | Disabled | Disabled     | 720/60P          | AVC-I 100 (AVC-I 50)<br>DVCPRO HD | 720-59.94P                                      | 4ch               |
| Setting ([SYSTEM MODE] = [720-50P])               |               |          |              | Recording format |                                   | <MON OUT> terminal (<SDI OUT/IN (OP)> terminal) |                   |
| [REC FORMAT]                                      | [CAMERA MODE] | [VFR]    | [FRAME RATE] |                  |                                   | Video format                                    | Audio             |
| [AVC-I100/50P]<br>[AVC-I50/50P]<br>[DVCPROHD/50P] | Disabled      | Disabled | Disabled     | 720/50P          | AVC-I 100 (AVC-I 50)<br>DVCPRO HD | 720-50P   | 4ch               |
| Setting ([SYSTEM MODE] = [480-59.94i])            |               |          |              | Recording format |                                   | <MON OUT> terminal (<SDI OUT/IN (OP)> terminal) |                   |
| [REC FORMAT]                                      | [CAMERA MODE] | [VFR]    | [FRAME RATE] |                  |                                   | Video format                                    | Audio             |
| [DVCPRO50/60i]<br>[DVCPRO/60i]<br>[DV/60i]        | Disabled      | Disabled | Disabled     | 480/60i          | DVCPRO50<br>DVCPRO<br>DV          | 480-59.94i                                      | 4ch<br>2ch or 4ch |
| Setting ([SYSTEM MODE] = [576-50i])               |               |          |              | Recording format |                                   | <MON OUT> terminal (<SDI OUT/IN (OP)> terminal) |                   |
| [REC FORMAT]                                      | [CAMERA MODE] | [VFR]    | [FRAME RATE] |                  |                                   | Video format                                    | Audio             |
| [DVCPRO50/50i]<br>[DVCPRO/50i]<br>[DV/50i]        | Disabled      | Disabled | Disabled     | 576/50i          | DVCPRO50<br>DVCPRO<br>DV          | 576-50i   | 4ch<br>2ch or 4ch |

When [1080-23.98PsF] (extra-cost option) is selected, SDI signal input recording is not available.

## Adjusting the white and black balance

To obtain high-quality video at all times using the camera, the white and black balance must be adjusted according to conditions.

To obtain higher quality, perform the adjustment in the order of AWB (white balance adjustment) → ABB (black balance adjustment) → AWB (white balance adjustment).

### NOTE

- When white or black balance is adjusted while video is disrupted by the generator lock, adjustment may not be performed correctly. Adjust white or black balance again after video has returned to normal.

### Adjusting the white balance

The white balance must be adjusted again when the lighting conditions change. To adjust the white balance automatically, follow the procedure below.

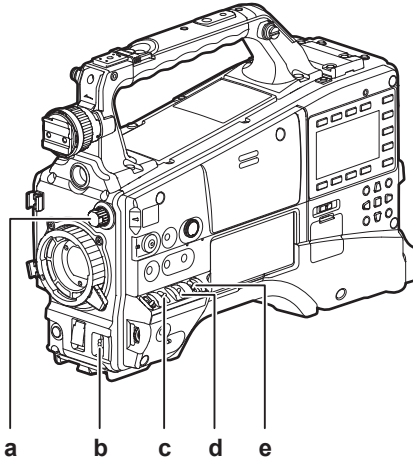

**a: <ND FILTER> dial**

Adjust the amount of light entering the MOS sensor.

**b: <AUTO W/B BAL> switch**

Used to execute the automatic white balance.

**c: <GAIN> switch**

Normally, set this to 0 dB. If conditions are too dark, set gain to an appropriate value.

■ When the <WHITE BAL> switch is set to <A>

**1 Set the <GAIN>, <OUTPUT>, and <WHITE BAL> switches.**

**2 Select the <ND FILTER> dial setting according to the light conditions.**

For details on setting example of the <ND FILTER> dial, refer to “Shooting and recording/playback functions section” (page 23).

**3 Place the white pattern at a point where the light conditions match those for the light source for the subject, and zoom in on the white pattern so that the white color appears in the screen.**

A white object (cloth or wall) near the subject may also be used instead of a white pattern. The illustration below shows the required size for the white space.

### NOTE

- Do not allow bright spotlights within the screen.
- The white object must appear at the center of the screen.

1/3 or more of the screen width

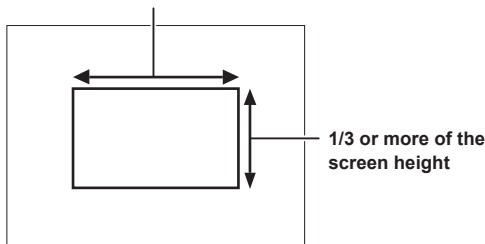

**4 Adjust the lens aperture.**

Activate the [Y GET] function (page 59), and adjust the iris so that the display is approximately 70%.

**d: <OUTPUT> switch**

Set this switch to <CAM>.

**e: <WHITE BAL> switch**

Set this switch to <A> or <B>.

**5 Set the <AUTO W/B BAL> switch towards the <AWB> side, and then release it.**

The switch returns to the central position with the white balance automatically adjusted.

**6 During an adjustment, the following message is displayed on the viewfinder screen:**

AWB Ach ACTIVE

**7 The adjustment is complete in several seconds, and the following message is displayed:**

- The adjusted value is automatically stored in the specified memory (A or B).

AWB A OK 3.2K

- If the [COLOR TEMP] setting of the scene file at this time is other than 0, [C TEMP+7] to [C TEMP-7] is displayed.

**8 If the color temperature of the subject is lower than 2300 K or higher than 9900 K, the following message is displayed:**

- If the arrow points down (↓), the actual temperature is lower than the indicated temperature, and if the arrow points up (↑), the actual temperature is higher than the indicated temperature.

AWB A OK 2.3K ↓

**When you have no time to adjust the white balance**

Set the <WHITE BAL> switch to <PRST>.

The value can be changed to 3200 K, 5600 K, and the user-specified variable value by pressing the <AUTO W/B BAL> switch towards the <AWB> side and pressing the <AUTO W/B BAL> switch towards the <AWB> side again while the color temperature is displayed. The variable value can be set at SmartUI. (page 138)

It can be set using the jog dial button, by assigning the [F.JOG CT] function to the <USER> button. (page 59)

**When the white balance has not been automatically adjusted**

When the white balance has not been successfully adjusted, the viewfinder screen displays an error message.

| Error message                | Description                                   |
|------------------------------|---|
| [AWB Ach NG] or [AWB Bch NG] | The color temperature is too high or too low. |
| [LOW LIGHT]                  | There is insufficient light.                  |
| [LEVEL OVER]                 | There is too much light.                      |

**Viewfinder display for white balance**

For details, refer to “Viewfinder status display” (page 70).

**Setting the auto tracking white balance (ATW) function**

The camera is equipped with the Auto Tracking White Balance (ATW) function that automatically tracks the white balance of images according to the lighting conditions.

The auto tracking white balance function can be assigned to <B> of the <WHITE BAL> switch by setting the [ATW] item on the setting menu [SW MODE] screen to [Bch].

The auto tracking white balance function can be assigned to the <USER> buttons (<USER MAIN>/<USER1>/<USER2>).

For details, refer to “Assigning functions to <USER> buttons” (page 59).

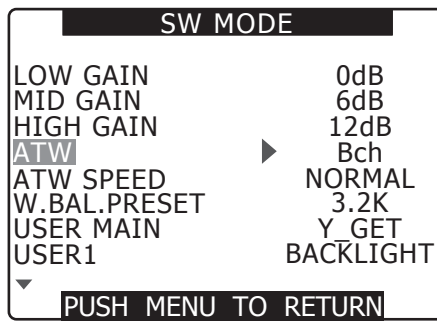

**Canceling the auto tracking white balance**

Press the <USER> buttons (<USER MAIN>/<USER1>/<USER2>) to which the auto tracking white balance function is assigned again, or select the <WHITE BAL> switch. However, when the auto tracking white balance function is set to <B> of the <WHITE BAL> switch, the function cannot be canceled with the <USER> buttons (<USER MAIN>/<USER1>/<USER2>).

**NOTE**

- This function does not guarantee 100% accuracy for the white balance. The tracking performance relative to changes in ambient lighting and white balance performance has been given a certain degree of latitude.

## Adjusting the black balance

Black balance must be adjusted in the following instances:

- When the camera is used for the first time
- When the camera has not been used for a long time
- When the ambient temperature has changed considerably
- When the gain switchover value has been changed
- When the [SYSTEM MODE] and [REC FORMAT] items on the setting menu [SYSTEM SETUP] screen has been changed

To shoot optimum video, we recommend adjusting the black balance immediately before shooting.

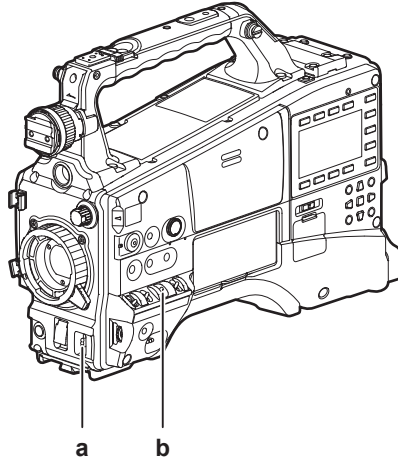

**a: <AUTO W/B BAL> switch**

Used to execute the automatic black balance.

**b: <OUTPUT> switch**

Set this switch to <CAM>.

**1 Set the <AUTO W/B BAL> switch towards <ABB> and then release it.**

The switch returns to the central position with the black balance automatically adjusted.

**2 During an adjustment, the following message is displayed on the viewfinder screen:**

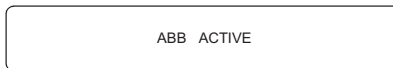

**3 The adjustment is complete in several seconds, and the following message is displayed:**

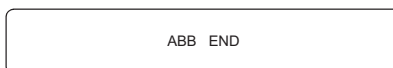

The adjusted value is automatically stored in memory.

**NOTE**

- Make sure that the lens connector is connected and that the lens aperture is in the close mode.
- During black balance adjustment, the aperture is set to automatically shut out light. Note, however, that [ABB NG] is sometimes displayed when light is not shut out due, for example, to the lens connector becoming disconnected.
- During recording, black balance cannot be adjusted.
- During the automatic black balance execution, recording to the P2 card is not performed by pressing the <REC> button.

## Setting the electronic shutter

### Setting the shutter mode and speed

- 1 Press the shutter switch positioned at OFF towards ON.

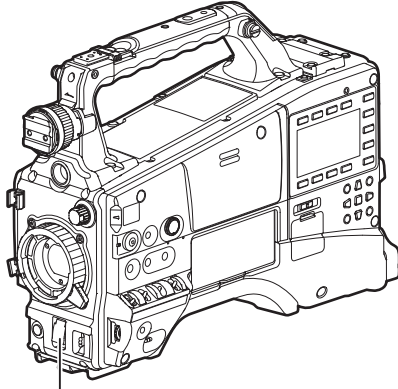

Shutter switch

- 2 Press the shutter switch from <ON> towards <SEL>, and repeat this operation until the desired mode or speed is displayed on the viewfinder screen.

- If all modes and speeds are available, the display changes in the following order.

- In the case of 60i, 60P recording

S/S → (1/15) → (1/30) → 1/60 → 1/100 → 1/120  
→ 1/250 → 1/500 → 1/1000 → 1/2000

- In the case of 30P recording

S/S → (1/15) → 1/30 → 1/50 → 1/60  
→ 1/120 → 1/250 → 1/500 → 1/1000

- In the case of 24P recording

S/S → (1/12) → 1/24 → 1/50 → 1/60  
→ 1/120 → 1/250 → 1/500 → 1/1000

- [S/S] displays the synchro scan mode.
- When [VFR] is [ON], the speed in parentheses ( ) cannot be selected.

#### NOTE

- Whichever mode the electronic shutter is used in, the higher the shutter speed, the lower the sensitivity of the camera becomes.
- When the aperture is in the automatic mode, it will increasingly open and the depth of focus will become shallower as the shutter speed is increased.
- The screen might be disrupted when the synchro scan and shutter settings are changed.
- Under lighting conditions using fluorescent lighting or other discharge tube, horizontal stripes might appear on screen. If this happens, this can be improved by adjusting the shutter speed.
- A subject that quickly crosses the camera may appear distorted when shot. This is due to the method applied for reading the signals from the pickup device (MOS sensor), and is not a malfunction.
- Red, blue or green spots might appear on screen at slow shutter speeds, though this is not a malfunction.

### Viewfinder screen display for shutter

For details, refer to "Viewfinder status display" (page 70).

### Setting the synchro scan mode

Follow the steps below to set the mode.

- 1 Press the shutter switch from the <ON> side towards the <SEL> side to set the camera to synchro scan mode [S/S].

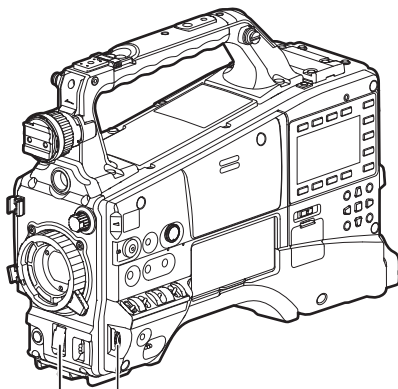

Jog dial button  
Shutter switch

- 2 Operate the jog dial button to switch the setting between the range of 1/60.0 and 1/249.8 seconds successively (in 60i mode).

Press and turn the jog dial button to change the shutter speed setting value faster.



**Variable ranges in each mode**

|  |                  |
|--|------------------|
| 60P/60i mode   | 1/60.0 - 1/249.8 |
| 50P/50i mode   | 1/50.0 - 1/250.0 |
| 25P/25PN mode  | 1/25.0 - 1/250.0 |
| 30P/30PN mode  | 1/30.0 - 1/249.8 |
| 24P/24PA/24PN mode   | 1/24.0 - 1/249.8 |
| When [SYNC SCAN TYPE] item on the setting menu [SCENE FILE] is [deg] | 3.0d to 360.0d   |

- The shutter speed may vary before and after [SYSTEM MODE] is switched.
- When the variable frame rate is less than 12P, the selection step becomes less precise.
- Set the [SYNC SCAN TYPE] item on the setting menu [SCENE FILE] screen to [deg] to set and display as the shutter open angle.

## Flash band compensation (FBC) function

The camera is equipped with a function for compensating and reducing band-like interference (called “flash band”) that occurs due to the MOS pickup device when shooting in environments where flash strobe light such as that from still cameras is present.

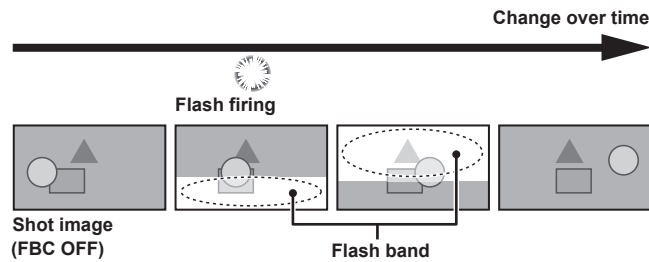

### Setting the flash band compensation function

Assign the flash band compensation function to the <USER> buttons (<USER MAIN>/<USER1>/<USER2>).

By pressing the <USER> buttons (<USER MAIN>/<USER1>/<USER2>) to which the flash band compensation function, the function turns on, and flash strobe from a still camera, etc. can be detected and compensated.

For details, refer to “Assigning functions to <USER> buttons” (page 59).

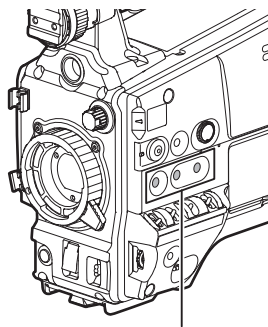

<USER MAIN>/<USER1>/<USER2> buttons

When the flash band compensation function is enabled, FBC is displayed on the status screen.\*

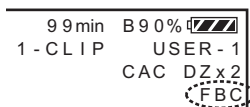

\* This is not displayed when the [OTHER DISPLAY] item on the setting menu [DISPLAY SETUP] screen is set to [OFF].

### NOTE

- When the flash strobe lights, the following phenomena may occur, but these are due to the flash band compensation function and are not malfunctions:
  - Moving subjects look as if they have stopped suddenly.
  - The resolution when the flash strobe light drops.
  - Horizontal lines appear in the video when the flash strobe lights.

### Using the flash band compensation function

The flash band compensation function is activated when there are large changes in brightness at the bottom of the screen regardless of whether there is flash strobe light. The flash band compensation function may be activated depending on the shooting environment such as where a bright window has zoomed in and then out, so, we recommend use of this function in shooting environments where flash strobe lighting is anticipated.

Even if flash strobe lighting occurs, sufficient flash band compensation function effect may not be obtained in some shooting environments.

### Operation conditions for the flash band compensation function

- The flash band compensation function can be used when the camera is in the 59.94i, 59.94P, 50i, or 50P mode, and the shutter switch is set to <OFF> and the digital zoom function turns off.
- Even if the flash band compensation function is activated, the flash band compensation function is forcibly turned off if the camera is changed to the mode where the flash band compensation function cannot be used.  
To use the function again, return to the mode where the function can be used, and press the <USER> buttons (<USER MAIN>/<USER1>/<USER2>) to turn on the flash band compensation function.
- Even if the flash band compensation function is activated, the flash band compensation function temporarily turns off when the shutter switch is set to <ON>. The flash band compensation function returns to on when the shutter switch next changes to <OFF>.
- The flash band compensation function turns off once the power is turned off.

## Assigning functions to <USER> buttons

Selected functions can be assigned to the <USER MAIN>, <USER1>, and <USER2> buttons.

Set the functions to be assigned at the [USER MAIN], [USER1], and [USER2] items on the setting menu [SW MODE] screen. Each item is set from the setting menu [SW MODE] screen.

In the factory settings, [Y GET] is assigned to the <USER MAIN> button, [BACK LIGHT] to the <USER1> button, and [TEXT MEMO] to the <USER2> button.

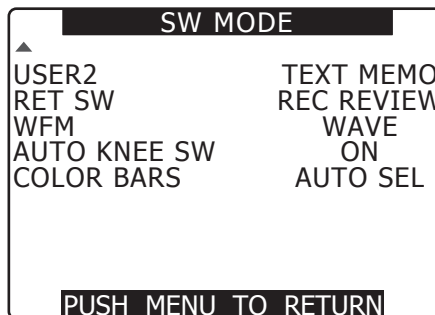
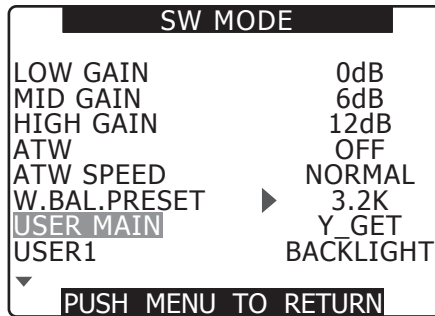

### Selectable functions

| Item name    | Description   |
|--------------|---|
| [SPOT LIGHT] | Assigns on/off of auto iris control for spotlight.  |
| [BACK LIGHT] | Assigns on/off of auto iris control for the backlight compensation.   |
| [ATW]        | Switches the auto tracking white balance function on/off.   |
| [ATW LOCK]   | Fixes the white balance value when pressing this item while the auto tracking white balance function is activated. Resumes the auto tracking white balance function when pressing again.  |
| [GAIN:18dB]  | Assigns the function for increasing gain to 18 dB.  |
| [D.ZOOMX2]   | Assigns the digital zoom function.  |
| [D.ZOOMX4]   | Zooms in on the field angle by 2x/4x vertically and horizontally.   |
| [FBC]        | Switches the flash band compensation function on/off.   |
| [Y GET]      | Assigns the function for displaying the brightness level of the frame area displayed near the center.   |
| [WFM]        | Assigns the function for switching the waveform display. Select the waveform display at the [WFM] item (page 124) on the setting menu [SW MODE] screen.   |
| [F.JOG CT]*  | When white balance is set to variable, a function which can set a variable value using the jog dial button is assigned. If you press the assigned <USER> button, [V*. *K] on the screen flashes and a variable value can be set. Pressing the assigned <USER> button again cancels the setting.   |
| [PRE REC]    | Assigns the function for switching the pre-recording function on/off.   |
| [REC REVIEW] | Assigns the rec review function.  |
| [TEXT MEMO]  | Assigns text memo recording.  |
| [SHOT MARK]  | Assigns the shot mark recording function.   |
| [SLOT SEL]   | Assigns P2 card slot selection.   |
| [A.MONI SEL] | Switches CH1 monaural, CH1/CH2 stereo, and CH2 monaural when the audio monitor channel is CH1/CH2. Switches CH3 monaural, CH3/CH4 stereo, and CH4 monaural when the audio monitor channel is CH3/CH4.   |
| [PC MODE]    | Assigns the function for switching USB device mode or USB host mode on/off. Select the USB device mode or USB host mode at the [PC MODE SEL] item on the setting menu [PC/USB/LAN] screen.  |
| [UPLINK S/S] | Assigns the data transfer start/stop function of the UPLINK device. <ul style="list-style-type: none"> <li>• Available when the Upgrade Software Key AG-SFU603G (UPLINK device control function (extra-cost option)) is installed. Items are grayed out and cannot be selected when it is not mounted.</li> <li>• For details, refer to the AG-SFU603G operating instructions.</li> </ul> |
| [PLAYLIST]   | Assigns the function for switching the playlist edit function on/off. <ul style="list-style-type: none"> <li>• Available when the Upgrade Software Key AG-SFU604G (Playlist edit function (extra-cost option)) is installed. Items are grayed out and cannot be selected when it is not mounted.</li> <li>• For details, refer to the AG-SFU604G operating instructions.</li> </ul>       |
| [INHIBIT]    | Disables assignment of functions.   |

\* When a setting is not performed within a certain period of time (approximately 12 seconds), the setting will be cancelled.

## Selecting audio input and adjusting recording levels

The camera supports independent 4-channel sound recording in any recording format (HD, SD).

When the [LVL] setting is set to [AUTO] on the [AUD02:INPUT] screen of SmartUI, the recording level of audio channels 1/2/3/4 is automatically adjusted. Also, you can adjust the level manually by setting to [MANU].

### Selecting audio input signals

The recording levels to audio channels 1/2/3/4 are selected by the [IN] setting on the [AUD02:INPUT] screen of SmartUI. (page 141)

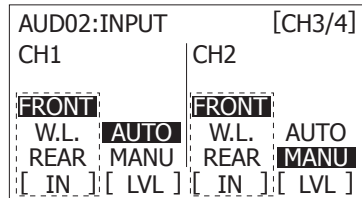

When using the DVCPRO or DV format, the factory settings are set to not record audio channels 3 and 4. When recording channel 4, set the [25M REC CH SEL] item on the setting menu [AUDIO SETUP] screen to [4CH].

Set the switch settings and input line in the [AUD02:INPUT] screen in SmartUI. (page 141)

### NOTE

- The audio signals recorded in 4-channel are output with SDI signals.
- Set audio-related details on the setting menu [AUDIO SETUP] screen. (page 125)

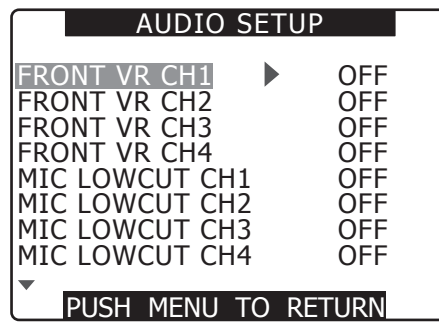

### Adjusting the recording levels

Adjust the recording level to audio channels 1/2 by the following procedure. Audio channels 3/4 can be set in the same manner.

- Press the <MONITOR SEL> button on the [HOME] screen of SmartUI so that the audio channel level meter displays CH1 and CH2, and make sure that the display is 1 and 2.
- Set [LVL] on the [AUD02:INPUT] screen of SmartUI to [MANU].
- Adjust the level by [+] or [-] on the [AUD01:LEVEL] screen of SmartUI while viewing the audio channel level meter display.

When the topmost bar (0 dB) is exceeded, [OVER] of the [OVER] display is illuminated to indicate that input audio is excessive. Adjust the maximum level so that the display does not reach 0 dB.

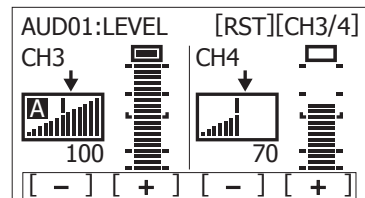

When operating the camera alone, use the <F.AUDIO LEVEL> dial to adjust the audio level.

Select the audio channel to be adjusted in advance, and while viewing the level meter of the viewfinder screen, adjust the level by the <F.AUDIO LEVEL> dial so that input does not become too great.

### Selecting <F.AUDIO LEVEL> dial function

Set whether to enable <F.AUDIO LEVEL> (audio recording level adjustment) dial operation by the [FRONT VR CH1], [FRONT VR CH2], [FRONT VR CH3], and [FRONT VR CH4] items on the setting menu [AUDIO SETUP] screen. When the input signal is selected in the menu, the <F.AUDIO LEVEL> dial operation is enabled for that input signal.

- The audio level when the <F.AUDIO LEVEL> dial is at level 10 becomes the value set in the [AUD01:LEVEL] screen of SmartUI.

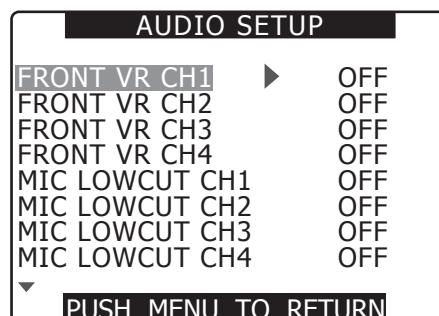

## Setting the time data

The camera provides time codes, user bits, and date/time (real time) data as time data, and they are recorded in frame in sync with video. They are also recorded as data for clip metadata files.

### Definition of time data

#### ■ Time code

Rec run and free run can be switched by the [TC\_MD] setting on the [SET01:TC/UB] screen of SmartUI.

- Free run: The time code always advances even when the power is turned off, and it can be handled in the same way as time. It can also be slaved to the time code input to the <TC IN/OUT> terminal.
- Rec run: The time code advances only during recording. Normally, the time code is recorded as sequential values to the previously recorded clip, and is held even if the power is turned off or the P2 card is replaced.

#### NOTE

- Values are not sequential in the following instances:
  - When a recorded clip has been deleted
  - When the 24P or 24PA frame rate has been switched to
  - When 24PN or 30PN has been switched to
  - When an error such as [REC WARNING] has stopped recording midway

#### ■ User bits

- Two types of user bits are built in: LTC UB (recorded as LTC, and output from the <TC IN/OUT> terminal and as LTC of HD SDI signals) and VITC UB (with DVCPRO, recorded in the VIDEO AUX area, and output as VITC of HD SDI signals).
- For LTC UB, you can select and record each respective user set values, time, year/month/day, with the same value as time codes, camera photo frame rate information, input value of external signals (from the <TC IN/OUT> terminal), etc.
- For VITC UB, the camera photo frame rate information is recorded.
- The LTC UB value at the start of recording is recorded to the user bits of the clip metadata.

#### ■ Date/time (real time)

- The internal clock measures the year, month, day, and time, and can display these on the viewfinder screen and on the output video from the <MON OUT> terminal, etc.
- The internal clock is used for measuring the free run time code while the power is off and as the time and year/month/day data of the user bits, as well as the reference for file generation times during clip recording, which determine the sorting order of thumbnails and the order of playback.
- It is also used to generate clip metadata and UMID (Unique Material Identifier).  
For details, refer to “Setting the date/time of the internal clock” (page 31).

### Recording and output of time codes and user bits

#### Recording and output of time codes

| System setting state |              |   |                         |   | Recording TC   |  | Output TC  |  | Display TC                     |
|----------------------|--------------|---|-------------------------|---|--|--|--|--|--------------------------------|
| [SYSTEM MODE]        | [REC SIGNAL] | [REC FORMAT]                                      | [CAMERA MODE]           | [FRAME RATE]*1  | LTC  | VITC   | TC OUT   | LTC of HD SDI, VITC  | TC tc (24/30 conversion)       |
| [1080-59.94i]        | [CAMERA]     | [DVCPROHD/60i]                                    | [60i], [30P]            | —   | [R-RUN]/[F-RUN]*2<br>[DF]/[NDF]<br>30 frames                         |  | LTC is output.   |  | TC: 30 frames<br>tc: 24 frames |
|                      |              |   | (60i)                   | [1FRAME]<br>to<br>[30FRAME]                                     |  |  |  |  |                                |
|                      |              |   | [24P],<br>[24PA]        | —   |  |  |  |  |                                |
|                      |              | [AVC-I100/60i]<br>[AVC-I50/60i]                   | —                       | [1FRAME]<br>to<br>[30FRAME]                                     | [R-RUN]/[F-RUN]*2<br>[DF]/[NDF]<br>30 frames                         | LTC is output.   |  |  |                                |
|                      |              | [AVC-I100/30PN]<br>[AVC-I50/30PN]                 | —                       | [30FRAME]   | [R-RUN]/[F-RUN]*2<br>[DF]/[NDF]<br>30 frames                         |  |  |  |                                |
|                      |              |   | Other than<br>[30FRAME] | [R-RUN] fixed<br>[DF]/[NDF]<br>At each valid frame<br>30 frames | Matched to recording TC at<br>start of recording<br>30 frames/second |  |  |  |                                |
|                      |              | [AVC-I100/24PN]<br>[AVC-I50/24PN]                 | —                       | [24FRAME]   | [R-RUN]/[F-RUN]*4<br>[NDF] fixed<br>24 frames                        | [R-RUN] fixed<br>[NDF] fixed<br>At each valid frame<br>24 frames | Converted to 30 frames based<br>on LTC.                              | Recording<br>TC: 24 frames<br>Playback<br>TC: 24 frames<br>tc: 30 frames |                                |
|                      |              |   |                         | Other than<br>[24FRAME]   | [R-RUN] fixed<br>[NDF] fixed<br>At each valid frame<br>24 frames     | [R-RUN] fixed<br>[NDF] fixed<br>At each valid frame<br>24 frames | Matched to recording TC at<br>start of recording<br>30 frames/second |  |                                |
| [1080-59.94i]        | [SDI IN]     | [DVCPROHD/60i]<br>[AVC-I100/60i]<br>[AVC-I50/60i] | —                       | —   | [R-RUN]/[F-RUN]*5<br>[DF]/[NDF]<br>30 frames                         |  | LTC is output.   |  | TC: 30 frames<br>tc: 24 frames |

Chapter 4 Adjustments and Settings for Recording — Setting the time data

| System setting state |                                   |  |   |   | Recording TC   |  | Output TC  |                     | Display TC   |
|----------------------|-----------------------------------|--|---|---|--|--|--|---------------------|--|
| [SYSTEM MODE]        | [REC SIGNAL]                      | [REC FORMAT]   | [CAMERA MODE]                                     | [FRAME RATE]*1                                    | LTC  | VITC   | TC OUT   | LTC of HD SDI, VITC | TC tc (24/30 conversion)   |
| [1080-23.98PsF]*1    | —                                 | [AVC-I100/24PN]<br>[AVC-I50/24PN]                    | —   | —   | [R-RUN]/[F-RUN]*6<br>[NDF] fixed<br>24 frames                    |  | LTC is output.<br>24 frames/second                                   |                     | Recording<br>TC: 24 frames<br>Playback<br>TC: 24 frames<br>tc: 30 frames |
| [720-59.94P]         | [CAMERA]                          | [DVCPROHD/60P]<br>[AVC-I100/60P]<br>[AVC-I50/60P]    | —   | Other than<br>[24FRAME]                           | [R-RUN]/[F-RUN]*2<br>[DF]/[NDF]<br>30 frames                     |  | LTC is output.   |                     | TC: 30 frames<br>tc: 24 frames   |
|                      |                                   |  | —   | [24FRAME]   | [R-RUN]/[F-RUN]*3<br>[NDF] fixed<br>30 frames                    |  |  |                     |  |
|                      |                                   | [DVCPROHD/30PN]<br>[AVC-I100/30PN]<br>[AVC-I50/30PN] | —   | [30FRAME]   | [R-RUN]/[F-RUN]*7<br>[DF]/[NDF]<br>30 frames                     |  |  |                     |  |
|                      |                                   |  | —   | Other than<br>[30FRAME]                           | [R-RUN] fixed<br>[DF]/[NDF]<br>At each valid frame<br>30 frames  |  | Matched to recording TC at<br>start of recording<br>30 frames/second |                     |  |
|                      |                                   | [DVCPROHD/24PN]<br>[AVC-I100/24PN]<br>[AVC-I50/24PN] | —   | [24FRAME]   | [R-RUN]/[F-RUN]*4<br>[NDF] fixed<br>24 frames                    |  | LTC is<br>converted to<br>30 frames and<br>output.                   | LTC is output.      | Recording<br>TC: 24 frames<br>Playback<br>TC: 24 frames<br>tc: 30 frames |
|                      |                                   |  | —   | Other than<br>[24FRAME]                           | [R-RUN] fixed<br>[NDF] fixed<br>At each valid frame<br>24 frames |  | Matched to recording TC at<br>start of recording<br>30 frames/second |                     |  |
|                      | [SDI IN]                          | [DVCPROHD/60P]<br>[AVC-I100/60P]<br>[AVC-I50/60P]    | —   | —   | [R-RUN]/[F-RUN]*5<br>[DF]/[NDF]<br>30 frames                     |  | LTC is output.   |                     | TC: 30 frames<br>tc: 24 frames   |
| [480-59.94i]         | [CAMERA]                          | [DVCPRO50/60i]<br>[DVCPRO/60i]<br>[DV/60i]           | [60i], [30P]                                      | —   | [R-RUN]/<br>[F-RUN]*2<br>[DF]/[NDF]<br>30 frames                 | Same value<br>as LTC<br>(except, none<br>at DV)                      | LTC is output.   | None                | TC: 30 frames<br>tc: 24 frames   |
|                      |                                   |  | [24P],<br>[24PA]                                  | —   | [R-RUN]/<br>[F-RUN]*3<br>[NDF] fixed<br>30 frames                |  |  |                     |  |
|                      | [SDI IN]                          | —  | —   | [R-RUN]/<br>[F-RUN]*5<br>[DF]/[NDF]<br>30 frames  |  |  |  |                     |  |
| [1080-50i]           | [CAMERA]                          | [DVCPROHD/50i]                                       | [50i], [25P]                                      | —   | [R-RUN]/[F-RUN]*2<br>25 frames                                   |  | LTC is output.   |                     | TC: 25 frames  |
|                      |                                   |  | (50i)   | [1FRAME]<br>to<br>[25FRAME]                       |  |  |  |                     |  |
|                      |                                   | [AVC-I100/50i]<br>[AVC-I50/50i]                      | —   | [1FRAME]<br>to<br>[25FRAME]                       |  |  |  |                     |  |
|                      | [AVC-I100/25PN]<br>[AVC-I50/25PN] | —  | [25FRAME]<br>Other than<br>[25FRAME]              | [R-RUN] fixed<br>At each valid frame<br>25 frames |  | Matched to recording TC at<br>start of recording<br>25 frames/second |  |                     |  |
|                      | [SDI IN]                          | [DVCPROHD/50i]<br>[AVC-I100/50i]<br>[AVC-I50/50i]    | —   | —   | [R-RUN]/[F-RUN]*5<br>25 frames                                   |  | LTC is output.   |                     | TC: 25 frames  |
| [720-50P]            | [CAMERA]                          | [DVCPROHD/50P]<br>[AVC-I100/50P]<br>[AVC-I50/50P]    | —   | [1FRAME]<br>to<br>[50FRAME]                       | [R-RUN]/[F-RUN]*2<br>25 frames                                   |  | LTC is output.   |                     | TC: 25 frames  |
|                      |                                   | [DVCPROHD/25PN]<br>[AVC-I100/25PN]<br>[AVC-I50/25PN] | —   | [25FRAME]   | [R-RUN]/[F-RUN]*7<br>25 frames                                   |  |  |                     |  |
|                      |                                   |  | —   | Other than<br>[25FRAME]                           | [R-RUN] fixed<br>At each valid frame<br>25 frames                |  | Matched to recording TC at<br>start of recording<br>25 frames/second |                     |  |
|                      |                                   | [SDI IN]   | [DVCPROHD/50P]<br>[AVC-I100/50P]<br>[AVC-I50/50P] | —   | —  | [R-RUN]/[F-RUN]*5<br>25 frames                                       |  | LTC is output.      |  |

Chapter 4 Adjustments and Settings for Recording — Setting the time data

| System setting state |              |  |               |                | Recording TC                       |   | Output TC      |                     | Display TC               |
|----------------------|--------------|--|---------------|----------------|------------------------------------|---|----------------|---------------------|--------------------------|
| [SYSTEM MODE]        | [REC SIGNAL] | [REC FORMAT]                           | [CAMERA MODE] | [FRAME RATE]*1 | LTC                                | VITC  | TC OUT         | LTC of HD SDI, VITC | TC tc (24/30 conversion) |
| [576-50i]            | [CAMERA]     | [DVCPRO50]<br>[DVCPRO/50i]<br>[DV/50i] | [50i], [25P]  | —              | [R-RUN]/<br>[F-RUN]*2<br>25 frames | Same value<br>as LTC<br>(except, none<br>at DV) | LTC is output. | None                | TC: 25 frames            |
|                      | [SDI IN]     |  | —             | —              | [R-RUN]/<br>[F-RUN]*5<br>25 frames |   | LTC is output. |                     | TC: 25 frames            |

- \*1 This becomes valid when the production pack (extra-cost option) is installed.
- \*2 For free run, the time code is slaved to the input TC of the <TC IN/OUT> terminal.
- \*3 For free run, the time code is slaved when the input TC of the <TC IN/OUT> terminal is a non-drop frame. However, it cannot be slaved during recording.
- \*4 For free run, the time code is slaved to the value obtained by conversion to 24 frames when the input TC of the <TC IN/OUT> terminal is a 30-frame non-drop frame. However, it cannot be slaved during recording.
- \*5 For free run, the time code is slaved to the input TC of the <TC IN/OUT> terminal. It is not slaved to LTC or VITC of the SDI input signal.
- \*6 For free run, the time code is slaved when the input TC of the <TC IN/OUT> terminal is a non-drop frame of 24 frames. However, it cannot be slaved during recording.
- \*7 For free run, the time code is slaved to the input TC of the <TC IN/OUT> terminal. However, it cannot be slaved during recording.

Recording and output of user bits

| System setting state |   |  |  |   | Recording UB          |                        | Output UB                         |                        |                        |                                      |                       |                        |
|----------------------|---|--|--|---|-----------------------|------------------------|-----------------------------------|------------------------|------------------------|--------------------------------------|-----------------------|------------------------|
| [SYSTEM MODE]        | [REC SIGNAL]                                      | [REC FORMAT]   | [CAMERA MODE]  | [FRAME RATE]                              | LTC UB                | VITC UB                | UB of <TC IN/OUT> terminal*1      | LTC UB of HD SDI*1     | VITC UB of HD SDI      |                                      |                       |                        |
| [1080-59.94i]        | [CAMERA]  | [DVCPROHD/60i]                                       | [60i], [30P]   | —   | Following [UB MODE]*2 | Frame rate information | LTC UB is output.                 |                        | Frame rate information |                                      |                       |                        |
|                      |   |  | (60i)  | [1FRAME]<br>to<br>[30FRAME]               |                       |                        |                                   |                        |                        |                                      |                       |                        |
|                      |   |  | [24P],<br>[24PA]                                     | —   |                       |                        |                                   |                        |                        |                                      |                       |                        |
|                      |   | [AVC-I100/60i]<br>[AVC-I50/60i]                      | —  | [1FRAME]<br>to<br>[30FRAME]               |                       |                        |                                   |                        |                        |                                      |                       |                        |
|                      |   | [AVC-I100/30PN]<br>[AVC-I50/30PN]                    | —  | —<br>[30FRAME]<br>Other than<br>[30FRAME] |                       |                        |                                   |                        |                        |                                      |                       |                        |
|                      |   | [AVC-I100/24PN]<br>[AVC-I50/24PN]                    | —  | [24FRAME]<br>Other than<br>[24FRAME]      |                       |                        |                                   |                        |                        |                                      |                       |                        |
| [SDI IN]             | [DVCPROHD/60i]<br>[AVC-I100/60i]<br>[AVC-I50/60i] | —  | —  |   | LTC UB is output.     |                        |                                   |                        |                        |                                      |                       |                        |
| [1080-23.98PsF]*3    | —   | [AVC-I100/24PN]<br>[AVC-I50/24PN]                    | —  | —   | Following [UB MODE]*2 | Frame rate information | LTC UB is output (native output). | Frame rate information |                        |                                      |                       |                        |
| [720-59.94P]         | [CAMERA]  | [DVCPROHD/60P]<br>[AVC-I100/60P]<br>[AVC-I50/60P]    | —  | Other than<br>[24FRAME]                   | Following [UB MODE]*2 | Frame rate information | LTC UB is output.                 |                        | Frame rate information |                                      |                       |                        |
|                      |   |  | —  | [24FRAME]                                 |                       |                        |                                   |                        |                        |                                      |                       |                        |
|                      |   |  | [DVCPROHD/30PN]<br>[AVC-I100/30PN]<br>[AVC-I50/30PN] | —   |                       |                        |                                   |                        |                        | [30FRAME]<br>Other than<br>[30FRAME] |                       |                        |
|                      |   | [DVCPROHD/24PN]<br>[AVC-I100/24PN]<br>[AVC-I50/24PN] | —  | [24FRAME]<br>Other than<br>[24FRAME]      |                       |                        |                                   |                        |                        |                                      |                       |                        |
|                      |   | [SDI IN]   | [DVCPROHD/60P]<br>[AVC-I100/60P]<br>[AVC-I50/60P]    | —   |                       |                        |                                   |                        |                        | —                                    |                       | LTC UB is output.      |
|                      |   | [CAMERA]   | [DVCPRO50/60i]<br>[DVCPRO/60i]<br>[DV/60i]           | [60i], [30P]                              |                       |                        |                                   |                        |                        | —                                    | Following [UB MODE]*2 | Frame rate information |
| [SDI IN]             |   | [24P],<br>[24PA]                                     | —  |   |                       |                        |                                   |                        |                        |                                      |                       |                        |
|                      |   |  | —  | —   |                       |                        |                                   |                        |                        |                                      |                       |                        |

## Chapter 4 Adjustments and Settings for Recording — Setting the time data

| System setting state |   |  |                      |                       | Recording UB          |                        | Output UB                    |                    |                        |
|----------------------|---|--|----------------------|-----------------------|-----------------------|------------------------|------------------------------|--------------------|------------------------|
| [SYSTEM MODE]        | [REC SIGNAL]                                      | [REC FORMAT]   | [CAMERA MODE]        | [FRAME RATE]          | LTC UB                | VITC UB                | UB of <TC IN/OUT> terminal*1 | LTC UB of HD SDI*1 | VITC UB of HD SDI      |
| [1080-50i]           | [CAMERA]  | [DVCPROHD/50i]                                       | [50i], [25P]         | —                     | Following [UB MODE]*2 | Frame rate information | LTC UB is output.            |                    | Frame rate information |
|                      |   | [AVC-I100/50i]<br>[AVC-I50/50i]                      | (50i)                | [1FRAME] to [25FRAME] |                       |                        |                              |                    |                        |
|                      |   | [AVC-I100/25PN]<br>[AVC-I50/25PN]                    | —                    | [1FRAME] to [25FRAME] |                       |                        |                              |                    |                        |
|                      | [DVCPROHD/50i]<br>[AVC-I100/50i]<br>[AVC-I50/50i] | —  | Other than [25FRAME] |                       |                       |                        |                              |                    |                        |
| [SDI IN]             | [DVCPROHD/50i]<br>[AVC-I100/50i]<br>[AVC-I50/50i] | —  | —                    |                       |                       |                        |                              |                    |                        |
| [720-50P]            | [CAMERA]  | [DVCPROHD/50P]<br>[AVC-I100/50P]<br>[AVC-I50/50P]    | —                    | [1FRAME] to [50FRAME] | Following [UB MODE]*2 | Frame rate information | LTC UB is output.            |                    | Frame rate information |
|                      |   | [DVCPROHD/25PN]<br>[AVC-I100/25PN]<br>[AVC-I50/25PN] | —                    | [25FRAME]             |                       |                        |                              |                    |                        |
|                      | [SDI IN]  | [DVCPROHD/50P]<br>[AVC-I100/50P]<br>[AVC-I50/50P]    | —                    | —                     |                       |                        |                              |                    |                        |
| [576-50i]            | [CAMERA]  | [DVCPRO50]   | [50i], [25P]         | —                     | Following [UB MODE]*2 | Frame rate information | LTC UB is output.            | None               | None                   |
|                      | [SDI IN]  | [DVCPRO/50i]<br>[DV/50i]                             | —                    | —                     |                       |                        |                              |                    |                        |

\*1 When [UB MODE] is set to [FRM.RATE], the pull-down frame rate information read out from VITC UB is output during native clip playback.

\*2 With [EXT], UB of the <TC IN/OUT> terminal is slaved.

\*3 This becomes valid when the production pack (extra-cost option) is installed.

### User bits settings

Set the user bits to record to sub-code area by the [UB MODE] item on the setting menu [RECORDING SETUP] screen.

| Item name  | Description   |
|------------|---|
| [USER]     | Records internal user values. User values can be set at [UBG] on the [SET01:TC/UB] screen of SmartUI. Setting values are held even when the power is turned off.<br>For details, refer to "How to input user bits" (page 64).   |
| [TIME]     | Records the time measured by the internal clock.  |
| [DATE]     | Records the hour digit of year/month/day/date-time measured by the internal clock.  |
| [EXT]      | Records the user bit values currently input to the <TC IN/OUT> terminal.  |
| [TCG]      | The time code value is recorded.  |
| [FRM.RATE] | The camera photo frame rate information is recorded.<br>When playing back clips recorded in native format, the same frame rate information as VITC UB is output regardless of the recorded value. Use at this setting when the editing device such as a computer uses the frame rate information of the user bits.<br>For details, refer to "Frame rate information recorded to user bits" (page 65). |

- Set to [EXT] when the user bits are slaved to the values currently input to the <TC IN/OUT> terminal.
- While the user bits are slaved, the [UB] display is inverted.
- Once the time code is slaved, the slave state is maintained even if there are no longer inputs to the <TC IN/OUT> terminal. However, the slave state of the user bits is canceled in the following instances:
  - When the [UB MODE] item is set to other than [EXT]
  - When [UB PRESET] has been performed
  - When the power is turned off
 Slaved values are held for the internal user values even after the slave state is canceled.

### How to input user bits

By setting user bits, information such as memos (date, time) up to eight digits long (hexadecimal) can be recorded.



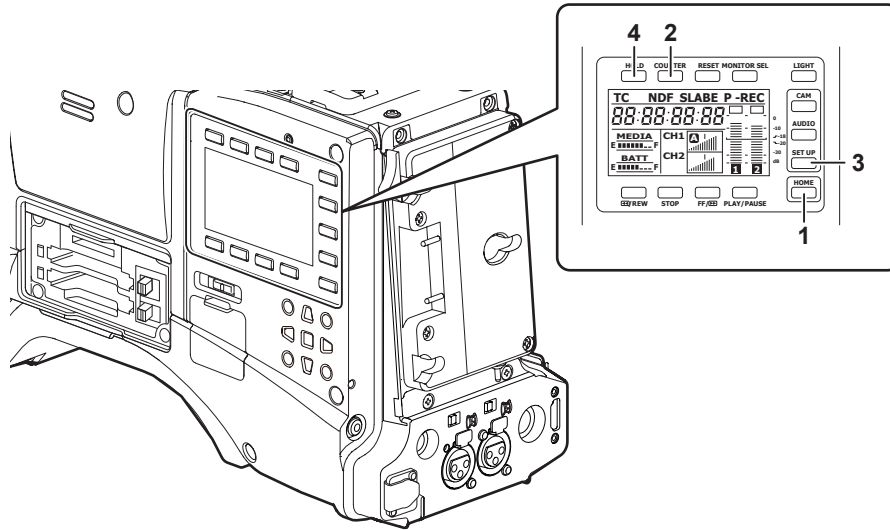

- 1 <HOME> button
- 2 <COUNTER> button
- 3 <SETUP> button
- 4 <HOLD> button

- 1 Use the <HOME> button to set the SmartUI screen to the [HOME] screen.
- 2 Use the <COUNTER> button to set the counter display to [UB].
- 3 Use the <SETUP> button to set the SmartUI screen to the [SET01:TC/UB] screen.
- 4 Set the [UBG] item to [SET].
- 5 Set the user bits.

| Item name | Description  |
|-----------|--|
| [→]       | The digit to be set (displayed inverted) moves to the right. |
| [+]       | The value of the inverted digit is incremented by one.       |
| [-]       | The value of the inverted digit is decremented by one.       |
| [RST]     | The values of all digits are reset to 0.                     |

- 6 Press [UBG] to apply the user bit setting values and end setting of user bits.

**NOTE**

\* Newly set values are invalid if the screen is switched without pressing [UBG].

- 7 Select [USER] at the [UB MODE] item on the setting menu [RECORDING SETUP] screen.

For details, refer to “Setting menu basic operations” (page 116).

**Retention of user bits in memory**

User bit settings are automatically saved in memory and are retained even if the power is turned off.

**Frame rate information recorded to user bits**

If the frame rate value of video information to be shot and recorded based on the frame rate set by each item on the setting menu [SYSTEM SETUP] screen or by the [FRAME RATE] item (option) is recorded in the user bits, it can be edited the editing device (such as computer editing software). This information is recorded to VITC UB at all times.

If the setting menu [UB MODE] item is set to [FRM.RATE], it is also recorded to user bits (LTC UB). In playback of clips recorded in native format, the same values as the frame rate information obtained by playing back recorded user bits are also output as HD SDI output signals or user bits of TC output from the <TC IN/OUT> terminal.

**Frame rate information**

The frame rate and video pull-down menu are linked to the time code and user bits as follows:

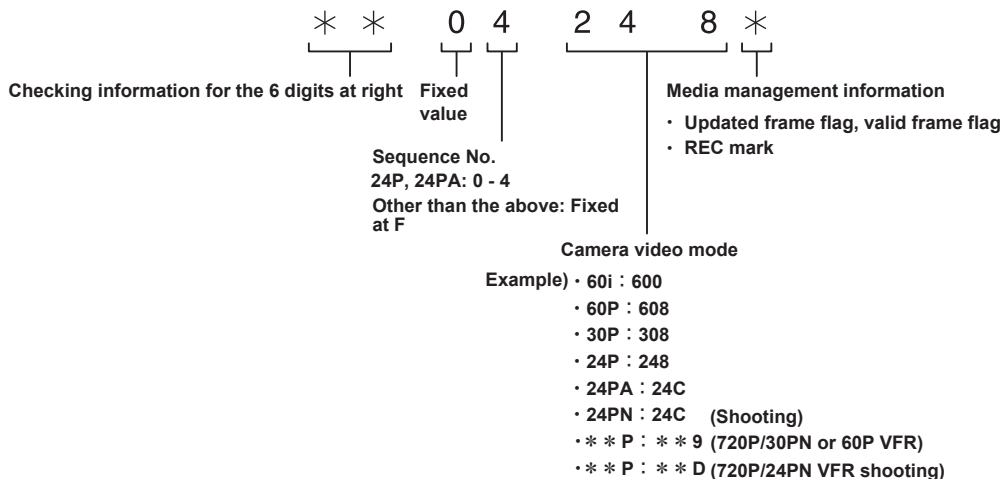

■ When 1080i or 480i

Frame rate:24P Over 60i (2:3)

Start field for updated frame

Time code frame digit

00 01 02 03 04 05 06 ... 23 24 25 26 27 28 29

Video

Ao|Ae|Bo|Be|Co|Ce|Do|De|Ao|Ae|Bo|Be|...|Co|Ce|Do|De|Ao|Ae|Bo|Be|Co|Ce|Do|De

Sequence No.

0 1 2 3 4 0 1 ... 3 4 0 1 2 3 4

Updated frame information

10 10 01 01 00 10 10 ... 01 00 10 10 01 01 00

Frame rate:24PA Over 60i (2:3:2)

Time code frame digit

00 01 02 03 04 05 06 ... 23 24 25 26 27 28 29

Video

Ao|Ae|Bo|Be|Co|Ce|Do|De|Ao|Ae|Bo|Be|...|Co|Ce|Do|De|Ao|Ae|Bo|Be|Co|Ce|Do|De

Sequence No.

0 1 2 3 4 0 1 ... 3 4 0 1 2 3 4

Updated frame information

10 10 01 00 10 10 10 ... 00 10 10 10 01 00 10

Frame rate:30P Over 60i (2:2)

Time code frame digit

00 01 02 ...

Video

Ao|Ae|Bo|Be|Co|Ce|...|

Updated frame information

10 10 10 ...

■ 720P mode

Frame rate:24P Over 60P (2:3)

Updated frame

Time code frame digit

00 01 02 03 04 05 06 ... 23 24 25 26 27 28 29

Video

A|A|B|B|B|C|C|D|D|D|A|A|B|B|...|C|D|D|D|A|A|B|B|B|C|C|D|D|D

Updated frame information

10 10 01 01 00 10 10 ... 01 00 10 10 01 01 00

Frame rate:30P Over 60P (2:2)

Time code frame digit

00 01 02 ...

Video

A|A|B|B|C|C|...|

Updated frame information

10 10 10 ...

Setting the time code

1 Set the [TC MODE] item on the setting menu [RECORDING SETUP] screen to [DF] or [NDF].

For details, refer to “Setting menu basic operations” (page 116).

- To advance the time code in the drop frame mode, set to [DF], and to advance it in the non-drop frame mode, set to [NDF]. Note, however, that the time code runs by [NDF] at all times in the 24P, 24PA and 24PN modes.

2 Use the <HOME> button to set the SmartUI screen to the [HOME] screen.

3 Set the counter display to [TC] by the <COUNTER> button.

4 Use the <SETUP> button to set the SmartUI screen to the [SET01:TC/UB] screen.

5 Set the [TCG] item to [SET].

6 Set the time code.

Time code available ranges

|                                |                           |
|--------------------------------|---------------------------|
| For 59.94 Hz (except for 24PN) | 00:00:00:00 - 23:59:59:29 |
| 24PN                           | 00:00:00:00 - 23:59:59:23 |
| For 50 Hz:                     | 00:00:00:00 - 23:59:59:24 |

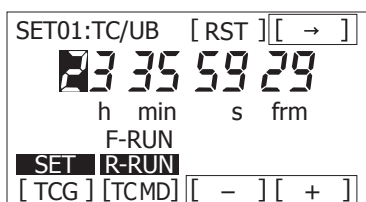

| Item name | Description  |
|-----------|--|
| [→]       | The digit to be set (displayed inverted) moves to the right. |
| [+]       | The value of the inverted digit is incremented by one.       |
| [−]       | The value of the inverted digit is decremented by one.       |
| [RST]     | The values of all digits are reset to 0.                     |

7 Press [TCG] to apply the time code setting values and end setting of the time code.

8 Press the <HOME> button to display the [HOME] screen of SmartUI.

NOTE

- When using in the 24P or 24PA mode, the time code setting is adjusted in 5-frame units. In the 24PN mode, the setting is adjusted to multiples of four, and in the 720/30PN or 720/25PN mode, it is adjusted to an even number. The time code cannot be set during recording.
- Newly set values are invalid if the screen is switched without pressing [TCG].

Time code function during battery replacement

Even during battery replacement, the backup mechanism functions, allowing the time code generator to continue operating.

NOTE

- When the <POWER> switch has been switched to <ON> → <OFF> → <ON>, the backup accuracy of the time code in the free run mode is approximately ±2 frames.

**Time code at the variable frame rate (VFR)**

- In the 24PN mode, recording is performed at 24 frames, and output is performed at 30 frames matched to 2:3 pull-down video.
- When [FRAME RATE] (shooting frame rate) is set to 24P, the advance speed of the time code for recording and output matches real time and does not match real time in modes other than 24P. (Example: In the 60P mode, the advance speed for recording becomes 60/24x.)
- In this instance, operation is fixed to recording run, and the time code value to output at the start of recording is matched to the recording time code.
- The same applies at other than 30P shooting in the 30PN mode.

■ **24PN recording for 60P shooting**

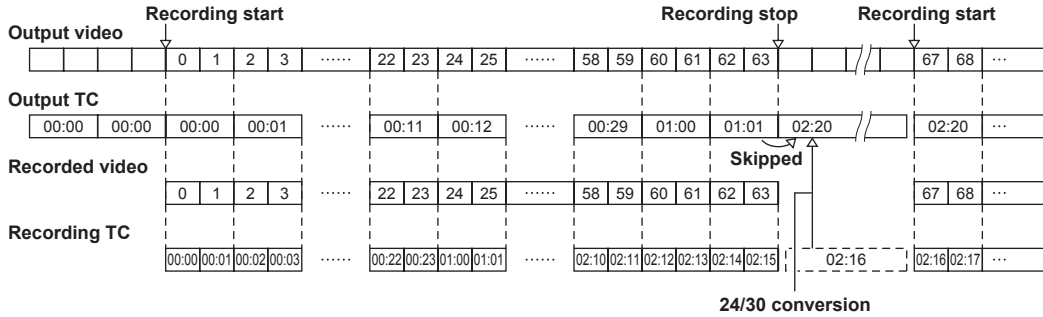

■ **30PN recording for 15P shooting**

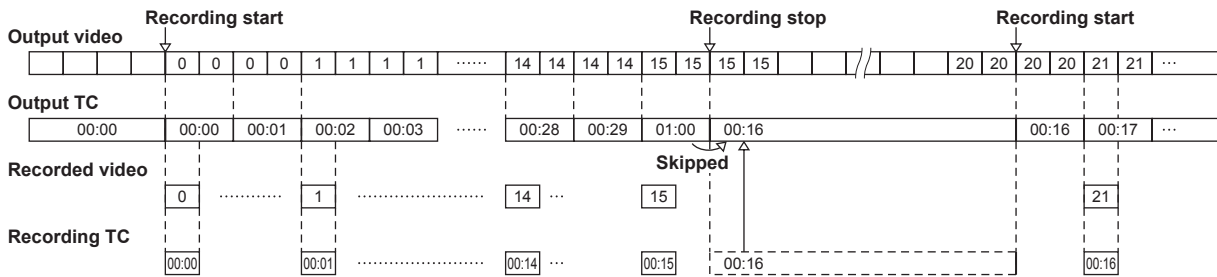

**Externally locking the time code**

The internal time code generator of the camera can be locked to an external generator. In addition, the time code generator of an external device can be locked to the internal time code generator of the camera.

**Example of connections for external locking**

As shown in the figure, connect both the reference video signal and the reference time code.

■ **When locking onto an external signal**

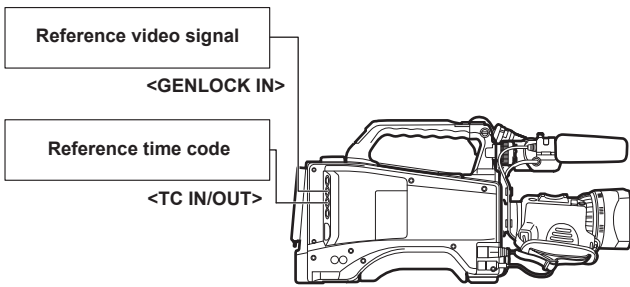

**NOTE**

- As a reference video signal, a composite video signal can also be input in addition to an HD Y reference signal.
- When the system mode is set to 480i, 576i (SD) and 720P, input the composite video signal.
- If the system mode is 720P, the video signal generator lock is activated when the HD-Y signal is input, however, the time code may shift by one field.
- When the generator lock input reference signal is disrupted, recording cannot be performed normally, and [TEMPORARY PAUSE IRREGULAR FRM SIG] flashes red on the viewfinder screen and the clip is divided. The continuity of the time code is not guaranteed. Recording resumes when the signal returns to normal. However, recording does not resume in interval recording, one-shot recording, and loop recording.

**External lock operation procedure**

To externally lock the time code, follow the steps below.

- 1 Set the [TC IN/OUT SEL] item on the setting menu [IN/OUT SEL] screen to [TC IN].  
For details, refer to "Setting menu basic operations" (page 116).
- 2 Set the counter display to [TC] by the <COUNTER> button.
- 3 Set the SmartUI screen to the [SET01:TC/UB] screen by the <SETUP> button.
- 4 Set the [TC\_MD] item to [F-RUN].

5 Press the <HOME> button to display the [HOME] screen of SmartUI.

A reference time code and reference video signal that are in a phase relationship (that conforms to time code specifications) are supplied to the <TC IN/OUT> and <GENLOCK IN> terminals.

- Now the built-in time code generator is locked with the reference time code.

- When the time code is externally locked, the time code is instantaneously locked to the external time code, the same value as the value of the external time code is output to the counter display area, and the [TC] display is inverted. Do not set to the recording mode for several seconds until the sync generator has stabilized.
  - Once the time code is slaved, the slave state\* is maintained even if there are no longer inputs to the <TC IN/OUT> or <GENLOCK IN> terminal. However, the slave state is canceled in the following instances:
    - When [TC PRESET] has been performed
    - When the power is turned off
    - When [TC MODE] has been switched
    - When [TC\_MD] has been set to [R-RUN] on the [SET01:TC/UB] screen of SmartUI
    - When [REC FORMAT] and [CAMERA MODE] have been switched
- \* Slave function refers to locking of the time code to TC IN input and making the time code continue as it is even if the time code is discontinued.

### Setting of user bits when the time code is externally locked

To externally lock user bits, set the [UB MODE] item on the setting menu [RECORDING SETUP] screen to [EXT]. The user bits are slaved to the user bit values input to the <TC IN/OUT> terminal regardless of [F-RUN]/[R-RUN]. For details, refer to “Setting the time data” (page 61), “User bits settings” (page 64).

### Canceling the external lock

Stop supply of the external time code, and set the [UB MODE] item on the setting menu [RECORDING SETUP] screen to other than [EXT].

### Cautions when switching the power supply from the battery to the external power supply while an external lock is active

To keep the time code generator power supply on continuously, connect an external power supply to the <DC IN> terminal and then remove the battery pack. If the battery pack is removed first, there is no guarantee that the time code will stay externally locked.

### External synchronization of the camera unit while an external lock is active

While an external lock is active, the generator lock is activated on the camera unit by the reference video signal input to the <GENLOCK IN> terminal.

#### NOTE

- To externally lock multiple units with the camera as the master device, set to the same setting as on the setting menu [CAMERA MODE] screen on the camera. Note that in a system using a mixture of interlaced and progressive scanning, the continuity of the video and time codes is not guaranteed.
- When externally locking in the 24P, 24PA and 24PN (native) modes, be sure to input non-drop frame time codes. An external lock is not possible using drop frames. Also, images may be disrupted the instant that the external lock is activated, though this is due to alignment of the 5-frame cycle and is not a malfunction.

### Supplying time codes to external devices

To supply the time code output according to the camera image or the playback image to a VTR or other recording devices, set the [TC IN/OUT SEL] item on the setting menu [IN/OUT SEL] screen to [TC OUT], and the [TC VIDEO SYNC] item to [VIDEO OUT].

Also, set the [GL PHASE] item on the setting menu [OTHER FUNCTIONS] screen to [HD SDI] or [COMPOSITE] according to the video output to be supplied, and set the [TC OUT] item on the [IN/OUT SEL] screen to [TCG/TCR].

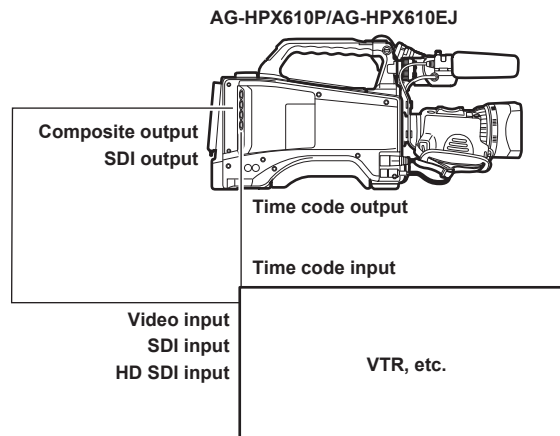

#### NOTE

- When the [TC VIDEO SYNC] item is set to [VIDEO OUT], the input time code is output according to the delayed video output.

■ When two cameras are connected and use one as a reference camera

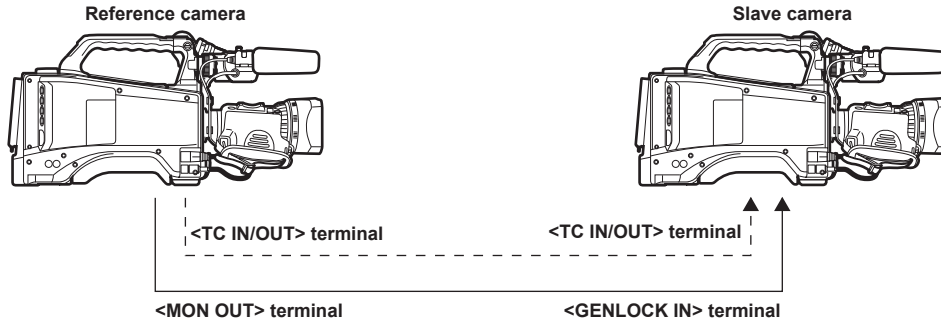

- Set whether to use the <TC IN/OUT> terminal as an output or input at the [TC IN/OUT SEL] item on the setting menu [IN/OUT SEL] screen.
- Set the [TC VIDEO SYNC] item on the setting menu [IN/OUT SEL] screen to [RECORDING], and the [GL PHASE] item on the [OTHER FUNCTIONS] screen to [COMPOSITE] for both cameras.
- If the [TC VIDEO SYNC] item on the setting menu [IN/OUT SEL] screen is set to [RECORDING], the same time code can be added to the video which is recorded at the same time with both cameras.
- The sub-carrier of the VBS signal from the <MON OUT> terminal cannot be externally locked.

**Connecting and setting the generator lock and time code input/output**

| Conditions of use of the camera |  |                      | Setting of the camera | Generator lock input and output phase of the camera<br>Matching: ✓, Not matching: × |                                  |                  |
|---------------------------------|--|----------------------|-----------------------|---|----------------------------------|------------------|
| Recording format                | Video/reference signal supplied externally | Generator lock input | [GL PHASE]            | SDI output (HD)   | Video output and SDI output (SD) | Time code output |
| 1080i                           | SDI output (1080i)                         | 1080i                | [HD SDI]              | ✓   | 90H delay                        | ✓                |
|                                 | Video output                               |                      | [COMPOSITE]           | 90H advance   | ✓                                | ✓                |
|                                 | SDI output (1080i)                         | SD (480i)            | [HD SDI]              | ✓   | 90H delay                        | ✓                |
|                                 | Video output                               |                      | [COMPOSITE]           | 90H advance   | ✓                                | ✓                |
| 720P                            | SDI output (720P)                          | 720P                 | [HD SDI]              | ✓   | 120H delay                       | ×                |
|                                 | Video output                               |                      | [COMPOSITE]           | 120H advance  | ✓                                | ×                |
|                                 | SDI output (720P)                          | SD (480i)            | [HD SDI]              | ✓   | 120H delay                       | ✓                |
|                                 | Video output                               |                      | [COMPOSITE]           | 120H advance  | ✓                                | ✓                |
| 480i                            | SDI output (480i)                          | SD (480i)            | Disabled              | None  | ✓                                | ✓                |
|                                 | Video output                               |                      |                       |   |                                  |                  |

**Counter setting and display**

When the counter display is set by using the <COUNTER> button, the counter value is displayed on the time code display area of the viewfinder screen. The counter value is indicated in hours:minutes:seconds. The value is not displayed during playback.

Two types of counts are available at the [REC COUNTER] item on the setting menu [DISPLAY SETUP] screen.

| Item name | Description   |
|-----------|---|
| [TOTAL]   | The count is totaled and continued until it is reset by button operation.<br>The counter value is held even if a P2 card is inserted or the power is turned off.  |
| [CLIP]    | The counter value is cleared and the counter is started from 0 (zero) each time recording is started.<br>This allows shooting while constantly verifying the recording time of the clip currently being recorded. |

**NOTE**

- Pressing the <RESET> button while the counter value is displayed resets the counter value and restarts the counter from 0 (zero).
- The counter value range is 0:00:00 to 9:59:59 and the count is incremented in 1-second units.

## Viewfinder status display

In addition to video, the viewfinder displays messages that indicate the camera settings and operation status, a center marker, safety zone marker, zebra patterns, and other information.

### Lamp display in the viewfinder

The example is for the AJ-HVF21KG. (For information on the viewfinder, refer to the Operating Instructions for the optional viewfinder.)

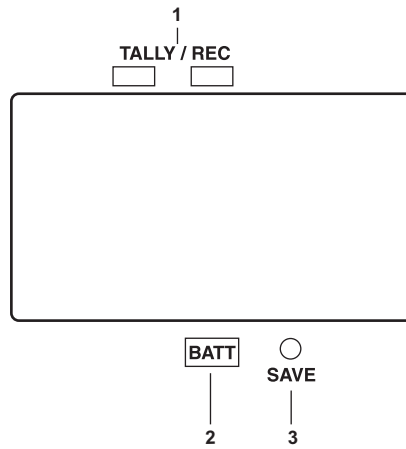

#### 1 TALLY/REC (recording) lamp

Illuminated red during recording, and flashes if an abnormality occurs.  
For details, refer to “Warning system” (page 157).

#### 2 BATT (battery) lamp

Starts flashing when the battery voltage drops and before the battery charge starts to run out, and is illuminated after the battery is completely flat. To prevent operation from being interrupted, replace the battery before it is nearly flat.  
For details, refer to “Warning system” (page 157).

#### 3 SAVE lamp

Not supported on the camera.

### Mode check screen displays (mode check function)

The camera settings and status can be displayed on the viewfinder screen.

Pushing the <DISP/MODE CHK> switch on the camera towards the <CHK> side switches the screen. The number of screens changes depending on the installation of additional options.

[STATUS] screen display → [PROXY/NETWORK] screen (only when the option is installed)

Each screen is displayed for approximately three seconds. Pushing the <DISP/MODE CHK> switch towards the <CHK> side while the screen is displayed moves the display to the next screen. While pushing the switch towards the <CHK> side, the status confirmation screen keeps displaying.

```

TC* 12 : 34 : 56 : 23 ● 1/2 99min B 90% [Battery Icon]
[P2] FULL 1 - PAUSE D IONC90 FLUO.
1 - CLIP CAC DZ x 2
1080i SLOT1 : NOT SUPPORTED FBC
AVC-I100 SLOT2 : NO CARD ABBNG
[60] MAIN : Y GET AWBNG
[SD1] 119min 1 : BACK LIGHT P3.2K
LT . BOX 2 : TEXT MEMO 0dB
EX 83% ND1
[Progress Bar] SEP 1 2012 23 : 59 : 59
60 : 24 PN [A.REC] DRS SPOT MF60
[Icons] 1/1 23 . 4 F5 . 6 Z60
    
```

[STATUS] screen

```

<PROXY>
MEDIA : P2&SD
MODE : STD 2CH MP4
SUPER : UPPER
PROXY BOARD ERROR

<NETWORK>
NETWORK : LAN
ERROR
STREAM : ERROR
!PRE REC
    
```

[PROXY/NETWORK] screen (option)

Configuration of status display on viewfinder screen

The status indicators are displayed on the normal screen.

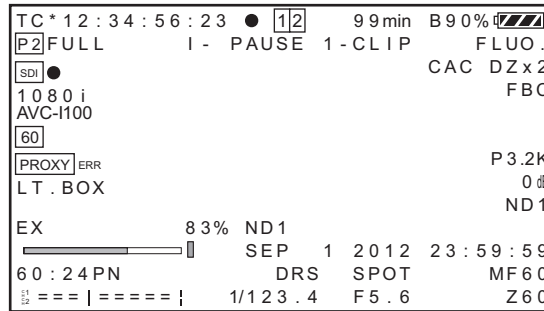

Selecting display items on viewfinder screen

To select display items on the viewfinder screen, switch display [ON]/[OFF] or type at each item on the setting menu [DISPLAY SETUP] screen. For details, refer to “Setting menu basic operations” (page 116).

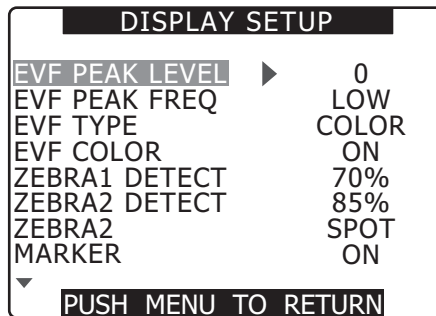

Screen display

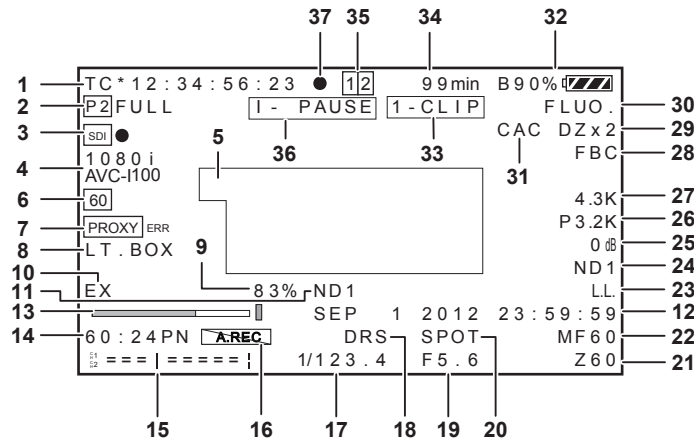

1 Time code display

Every time you press the <COUNTER> button, you switch to the following data (or no display).

| Counter | Counter value (recording mode only)  |
|---------|--|
| [TC]    | Time code value<br>When operating in the drop frame mode, the “:” (colon) between the second and frame turns into a “.” (dot).   |
| [tc]    | Time code value (displayed after frame digit is converted to 24 frames)<br>When operating in the drop frame mode, the “:” (colon) between the second and frame turns into a “.” (dot).   |
| [UB]    | User bits value  |
| [FR]    | Information of frame rate used for shooting <ul style="list-style-type: none"> <li>● FR60I -: 60i interlace mode (60 fields/sec)</li> <li>● FR60P -: 60P progressive mode (60 frames/sec)</li> <li>● FR30P -: 30P progressive mode (30 frames/sec)</li> <li>● FR24P*: 24P progressive mode (24 frames/sec)</li> <li>● FR24PA*: 24P advance mode (24 frames/sec)</li> <li>● FR50I -: 50i interlace mode (50 fields/sec)</li> <li>● FR50P -: 50P progressive mode (50 frames/sec)</li> <li>● FR25P -: 25P progressive mode (25 frames/sec)</li> </ul> *: In the FR24P and FR24PA modes, the sequence information of frame conversion is displayed at the last digit. |

**NOTE**

- [TC], [tc], and [UB] become white dropout display [TC] → [TC] when locked to TC IN input.

**2 Warning information display**

|           |  |
|-----------|--|
| [P2]      | Flashes when the P2 card is not inserted or recording is disabled.   |
| [P2 FULL] | Flashes when there is no space remaining on the P2 card.   |
| [P2 LACK] | Flashes when there is insufficient remaining space on the P2 card while loop recording is set.   |
| [BATT]    | Illuminated when the built-in battery for the internal clock is flat.<br>For details, refer to "Charging the built-in battery" (page 156). |

**3 HD SDI REMOTE recording status and UPLINK device connection information**

- This indicates the recording start and stop control status for the external device connected by <SDI OUT/IN (OP)>.
- This is displayed when the setting of the [HD SDI REMOTE] item on the setting menu [IN/OUT SEL] screen is [ON].

|         |  |
|---------|--|
| [SDI●]  | Recording control instruction status for externally connected device |
| [SDI  ] | Recording standby instruction status for externally connected device |

- For details on UPLINK device connection information, refer to the operating instructions of Upgrade Software Key AG-SFU603G (UPLINK device control function (extra-cost option)).

**4 Recording format and system mode display**

|                         |  |
|-------------------------|--|
| <b>System mode</b>      | <ul style="list-style-type: none"> <li>• 1080i</li> <li>• 1080 (1080-23.98PsF mode)</li> <li>• 720P</li> <li>• 480i</li> <li>• 576i</li> </ul>   |
| <b>Recording format</b> | <ul style="list-style-type: none"> <li>• When the system mode is 1080i, 720P                             <ul style="list-style-type: none"> <li>- [AVC-I100]: AVC-Intra 100 format</li> <li>- [AVC-I50]: AVC-Intra 50 format</li> <li>- [DVCPROHD]: DVCPRO HD format</li> </ul> </li> <li>• When the system mode is 480i (576i)                             <ul style="list-style-type: none"> <li>[DVCPRO50], [DVCPRO], [DV]</li> </ul> </li> </ul> |

**5 Information display**

The following information is displayed according to the status:

- Auto white balance and auto black balance operation status
- Warning displays, error displays
- Switch and button operation information

For details, refer to "Information display in center" (page 75).

**6 System frequency display**

Displays system frequency.

|               |   |
|---------------|---|
| [60]          | When the system frequency set by the [SYSTEM MODE] item on the setting menu [SYSTEM SETUP] screen is 59.94 Hz |
| [50]          | When the system frequency set by the [SYSTEM MODE] item on the setting menu [SYSTEM SETUP] screen is 50 Hz    |
| [24] (option) | When the system frequency set by the [SYSTEM MODE] item on the setting menu [SYSTEM SETUP] screen is 23.98 Hz |

**7 Proxy information display (option):**

Displayed when the video encoder board (extra-cost option) is installed.

|             |   |
|-------------|---|
| [SD END]    | Flashes white when there is less than one minute of recording space left. It is displayed during recording. |
| [SD ***min] | Displayed only during a mode check executed on the proxy SD memory card capacity.                           |
| [PROXY ERR] | Displayed when an error has occurred on the video encoder board or in proxy recording.                      |

**8 Letterbox recording display**

Displayed when the recording format is 480i or 576i, and [LETTER BOX] is selected at the [ASPECT CONV] item on the setting menu [SYSTEM SETUP] screen is selected and letterbox recording is being executed.

**9 Y GET brightness display**

In the Y GET mode, the image level in the frame displayed near the center of the screen is displayed as 0% to 100%.

**10 Extender**

Displays [EX] when the lens extender is used.

**11 Recommended ND filter display**

Displays the ND filter recommended for the current shooting conditions.



12 Date and time display

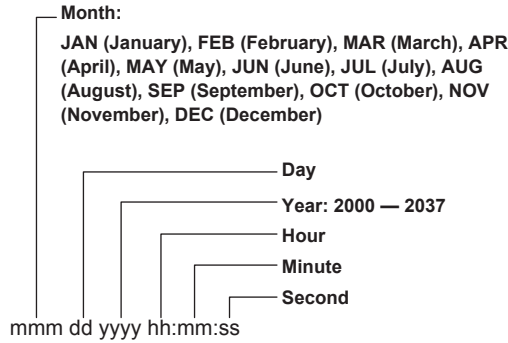

13 Focus bar display

Displays the following at the bottom left of the viewfinder. The high-frequency component of the video is converted to a numerical value and displayed.

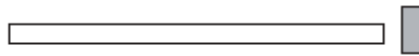

|            |                   |
|------------|-------------------|
| White bar  | Focus bar display |
| Green line | Peak display      |

14 Shooting/recording and playback frame rate display

In the native recording mode, the number of shooting frames and number of recording/playback frames are displayed.

Example) 60:24PN (variable frame rate 24PN recording (VFR) in 60P shooting)

By playback, this becomes 24P Over 60P at 2:3 pull-down to indicate that playback is 24/60x slow playback.

In Standard recording, only the shooting frame rate is displayed.

Example) 24PA (2:3:3:2 pull-down over60i recording at 24PA)

15 Audio level meter display

- When the [HEADROOM] setting on the [AUDIO SETUP] screen is set to [-20dB]

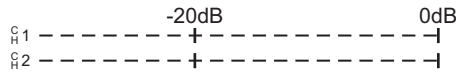

- When the [HEADROOM] setting on the [AUDIO SETUP] screen is set to [-18dB]

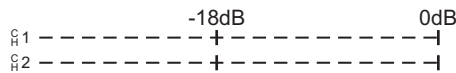

- When a monaural channel is selected on the [AUD03:MONI] screen of SmartUI

The channel number that is not selected is not displayed.

The recording level of each channel is displayed with each level bar, and this indicates that the audio channels to be output to speaker, the <PHONES> and <AUDIO OUT> terminals are monaural.

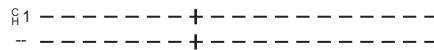

When audio channel 1 is selected

16 Audio recording not available display

In native variable frame rate recording, the [A-REC] mark is displayed when audio is not recorded.

This is also displayed in interval recording and one-shot recording since audio is not recorded (mute recording).

17 Shutter speed display

Displays the shutter speed.

With synchro scan, the display is as set by the [SYNC SCAN TYPE] item on the setting menu [SCENE FILE] screen (hour (minute) display or shutter open angle display).

18 Dynamic range stretcher (DRS) function display

Displayed when the dynamic range stretcher function is activated.

19 Iris display

Displays F value.

- [NC] is displayed when a lens connector is not connected.

20 Auto iris control display

|        |   |
|--------|---|
| [SPOT] | Auto iris control for spotlight                   |
| [BACK] | Auto iris control for the backlight compensation. |

This is displayed also when the lens iris is set manually, though no operation is performed.

**21 Zoom position display**

Displays the zoom position with [Z00] (maximum wide-angle) - [Z99] (maximum zoom).

- When connecting the lens that supports auto focus, the unit can be switched to [mm/m] at the [ZOOM/FOCUS] item on the setting menu [DISPLAY SETUP] screen.
- The focus position display does not move linearly. [NUMBER] is displayed as the factory setting.

**22 Focus control information**

Displays the focus control information with [99] to [00]. [AF] is displayed when auto focus is set with the auto-focus compatible lens connected, and [MF] is displayed when manual focus is set. When auto-focus incompatible lens is connected, the focus control information is not displayed. When connecting the lens that supports auto focus, the unit can be changed at the [ZOOM/FOCUS] item on the setting menu [DISPLAY SETUP] screen.

**23 Low-light display**

The [SHOOTING MODE] item on the setting menu [SYSTEM SETUP] screen is set to [LOW LIGHT].

**24 ND filter display**

- The currently selected ND filter is displayed.
- When ND-- is displayed, the <ND FILTER> dial is out of position (i.e. not within <1> to <4>), so check the position of the <ND FILTER> dial.

**25 Gain display**

Displays the gain value of the image amplifier configured.

**26 <WHITE BAL> switch position display**

Displays the currently selected position. Also, white balance operation is displayed when the automatic white balance is preset. In auto tracking white balance function mode, [ATW] is displayed, and when the auto tracking white balance function is locked, [LOCK] is displayed. If the preset is set to [VAR], the set color temperature such as [V3.2K] is displayed.

**27 Ach/Bch color temperature display**

Sets the <WHITE BAL> switch to either <A> or <B>, and displays the color temperature when white balance is automatically adjusted.

**28 Flash band compensation (FBC) function display**

Displayed when the flash band compensation function is activated.

**29 Digital zoom factor display**

Displays digital zoom factor.

|        |         |
|--------|---------|
| [DZx2] | 2 times |
| [DZx4] | 4 times |

**30 Scene file name display**

The [SCENE FILE] (F1 to F6) scene file name is displayed.

**31 Chromatic aberration compensation function (CAC)**

Displayed when the chromatic aberration compensation function is active. (Only when the mode check is performed)

**32 Battery charge level display**

This changes [🔋] → [🔋] → [🔋] → [🔋] → [🔋] as the battery charge level gets lower. When there is no more battery charge left, [🔋] ([🔋]) flashes. (When the AC adaptor is used, other than [🔋] may be displayed, but this is not a problem.)

■ **Batteries that support the battery charge level % (percentage) display**

The battery charge level is displayed as follows:

|         |  |
|---------|--|
| [B* *%] | 10% - 99%<br>Displays the battery charge level as %. |
| [MAX]   | Displays in a fully charged state.                   |
| [EMP]   | Displays when the charge level is less than 10%.     |

■ **Batteries that do not support the battery charge level % (percentage) display**

The battery voltage is displayed.

|         |                                     |
|---------|-------------------------------------|
| [13.5V] | Displays the current voltage value. |
|---------|-------------------------------------|

**33 One-clip recording mode status display**

|          |   |
|----------|---|
| [1-CLIP] | A new clip is about to be recorded by one-clip recording.                             |
| [1*CLIP] | A new clip can be combined with the previous clip and recorded by one-clip recording. |

**34 Media free space display**

- When the [P2CARD REMAIN] item on the setting menu [DISPLAY SETUP] screen is set to [ONE-CARD], the slot number is displayed to the left of the remaining space of the current P2 card for recording. When [TOTAL] is set, the total remaining space of the two cards is displayed.
- The [ONE-CARD] and [TOTAL] display is swapped in the mode check.
- Nothing is displayed while free space is being calculated and in the USB device mode. [LOOP] is displayed during loop recording.
- In the mode check during loop recording, the standard recording time that is possible by loop recording is displayed.
- Free space is displayed in 1-minute units in the range 0 to 999 minutes. 999 minutes is displayed for remaining space exceeding 999 minutes.
- The display flashes when the remaining space falls to two minutes or below.

**35 Media information display**

Displays the card slot in which the P2 card is inserted and basic information.

|                       |                              |
|-----------------------|------------------------------|
| [1] illuminated       | Recordable P2 card           |
| [1] illuminated green | P2 card for recording target |

|          |  |
|----------|--|
| flashing | The card is being recognized.  |
|          | No card inserted   |
|          | The card is write-protected.   |
|          | No remaining free space  |
|          | The card cannot be recognized.   |
|          | The P2 card is in an illegal format. (This can be corrected by formatting the card.) |

### 36 Recording/playback operation status display

|                                |   |
|--------------------------------|---|
| [REC]                          | Recording   |
| [PAUSE]                        | Standing by for recording   |
| [II]                           | Playback paused   |
| [▶]                            | Playback  |
| [▶▶][◀◀]                       | Fast-forward/fast-forward playback (fast-reverse/fast-reverse playback)   |
| [4X▶▶][4X◀◀]                   | 4x search   |
| [CLIP III▶]<br>[CLIP ◀III]     | Clip feed (clip return), cue up by individual clip units  |
| [CLIP&T III▶]<br>[CLIP&T ◀III] | Cue up by clip and text memo unit feed (return) (When the [SEEK SELECT] item on the menu [OTHER FUNCTIONS] screen is set to [CLIP&T]) |
| [START]                        | Displayed when recording of a new clip is started by one-clip recording.  |
| [END]                          | Displayed when combining of clips has ended by one-clip recording.  |

In the display off status, only [REC], [START], and [END] are displayed at the top right. These are also displayed when pre-recording, loop recording, interval recording, and one-shot recording are set.

#### ■ Special recording status display

This is displayed when the [REC FUNCTION] item on the setting menu [RECORDING SETUP] screen is set to [INTERVAL], [ONE SHOT], and [LOOP], or when pre-recording is set to [ON].

|      |  |
|------|--|
| [L-] | [LOOP] (loop recording)  |
| [I-] | [INTERVAL] (interval recording), [ONE SHOT] (one-shot recording) |
| [P-] | [PRE REC] (pre-recording)  |

### 37 System tally

Illuminated when the system tally is received, if using as the camera extension system in combination with the optional camera adaptor (AG-CA300G) and base station (AG-BS300).

### Information display in center

The following information is displayed (page 72).

### P2 card recording/playback information display

|  |   |   |
|--|---|---|
| [BOS]  | Top of the stream. From here, playback in the reverse direction is not possible.                                  |   |
| [CANNOT PLAY]  | Displayed when playback is not possible.  |   |
|  | [CARD ERR (1)], [CARD ERR (2)], [CARD ERR (1/2)]  | P2 card error in slot of indicated number |
|  | [UPDATING]  | Card information is being read.           |
| [CANNOT REC]   | Displayed when recording cannot be started by pressing the <REC> button.  |   |
| [EOS]  | End of the stream. From here, playback in the forward direction is not possible.                                  |   |
| [PRE REC ON], [PRE REC OFF], [PRE REC INVALID]       | Displayed when the <USER> buttons to which pre-recording is assigned are pressed.                                 |   |
| [SHOT MARK ON], [SHOT MARK OFF], [SHOT MARK INVALID] | Displayed when the <USER> buttons to which the shot mark is assigned or the <RET> button on the lens are pressed. |   |
| [SLOT SEL], [SLOT SEL INVALID]                       | Displayed when the <USER> buttons to which [SLOT SEL] is assigned are pressed.                                    |   |
| [TEXT MEMO], [TEXT MEMO INVALID]                     | Displayed when the <USER> buttons to which the text memo is assigned or the <RET> button on the lens are pressed. |   |

### Error and warning displays

These are displayed when an abnormality has occurred on the camera or the P2 card, etc. If the display is not corrected by turning the power off then back on again, either follow the displayed instructions to replace the card, or contact the shop of purchase.

|                     |  |
|---------------------|--|
| [CLIP DISCONTINUED] | Consistency with combined clips cannot be obtained by one-clip recording, and the clip cannot be combined at recording of the next clip.   |
| [DIR ENTRY NG CARD] | The P2 card directory is in an irregular layout. Operation is continued, however, data might not be recorded correctly. Immediately back up the data on the card and use it after formatting it again. |
| [FORMAT ERR!]       | The card does not conform to the P2 standard.  |
| [INCOMPATIBLE CARD] | The card cannot be used since it conforms to a different standard.   |

## Chapter 4 Adjustments and Settings for Recording — Viewfinder status display

|  |  |   |
|--|--|---|
| [LOW BATTERY]                                    | The battery is flat.   |   |
| [REC WARNING]                                    | An abnormality occurred during recording. Start the recording again. If the warning display persists, contact the shop of purchase.  |   |
| [CARD ERR (1)], [CARD ERR (2)], [CARD ERR (1/2)] | P2 card error in slot of indicated number<br><ul style="list-style-type: none"> <li>• If the warning continues to be displayed, turn off the power.</li> <li>• If the warning display persists after retrying recording, replace with another card.</li> </ul> |   |
| [ERROR]  | Other  |   |
| [OVER MAX# CLIPS]                                | An attempt was made to record more than the maximum number of clips (1000) that can be recorded to a single P2 card.   |   |
| [PULL DOWN ERROR]                                | Abnormality in video pull-down sequence in 24P mode, for example   |   |
| [REC RAM OVERFLOW]                               | Overflow of memory for recording   |   |
| [RUN DOWN CARD]                                  | The number of rewrites stipulated for the P2 card has been exceeded. Operation is continued, however, recording or playback might not be performed correctly. Replacement of the P2 card is recommended.   |   |
| [SYSTEM ERROR]                                   | This is displayed when an abnormality has occurred on the system. Turn off the power then back on again.   |   |
| [CAM MICON ERROR]                                | No response from camera microcontroller  |   |
| [P2 CONTROL ERROR]                               | P2 control error   |   |
| [P2 MICON ERROR]                                 | No response from P2 microcontroller  |   |
| [TEMPORARY PAUSE]                                | [IRREGULAR FRM SIG]  | Displayed when the reference signal for generator lock input is disrupted and recording is suspended. |
| [TURN POWER OFF]                                 | An abnormality occurred due to a card being removed while it was being accessed or the system mode was changed. Switch the power off and back on again.  |   |
| [VFR ON]   | [NO AUDIO RECORDING]   | Displayed when audio signals are not recorded because the VFR mode is set.                            |
| [WIRELESS RF]                                    | Wireless receiver reception is poor.   |   |

### Camera system status display

|                                       |   |
|---------------------------------------|---|
| [ABB ACTIVE]                          | Automatic black balance operation display   |
| [ATW ACTIVE]                          | Displayed when the <AUTO W/B BAL> switch is set to the <AWB> side while the auto tracking white balance function is activated.  |
| [ATW]/[ATW LOCK]                      | Displayed when the auto tracking white balance function is assigned, if the <WHITE BAL> switch is set to <B>.   |
| [AUTO KNEE ON]/[OFF]                  | Displayed when the <AUTO KNEE> selector switch setting was changed.   |
| [AWB * ch ACTIVE]                     | Automatic white balance operation display   |
| [AWB P3.2K]/[AWB P5.6K]/[AWB VAR*.*K] | Displays the assigned color temperature when the <WHITE BAL> switch is set at the <PRST> position. Also, displayed when an attempt is made to execute the automatic white balance at the <PRST> position. |
| [BACK LIGHT]/[OFF]                    | Displayed when the <USER> buttons to which the backlight for iris control is assigned are pressed and the status is switched.   |
| [DRS ON]/[OFF]                        | Indicates that the dynamic range stretcher operation is switched.   |
| [D.ZOOM **]                           | Displayed when the <USER> button where digital zoom function is assigned or the <RET> button on the lens is pressed to switch the status. (** displays ×2, ×4, and [OFF])                                 |
| [GAIN**dB]                            | Displayed when the gain value is switched.  |
| [ND NG]                               | Displayed when the ND filter is not at the correct position.  |
| [SCENE*****]                          | Displays the scene file name when the scene file number is changed to switch the scene file.  |
| [SHUTTER 1/****]/[OFF]                | Displayed when the shutter speed setting was switched.  |
| [SPOT LIGHT]/[OFF]                    | Displayed when the <USER> buttons to which the spot light for iris control is assigned are pressed and the status is switched.  |
| [FBC ON]/[OFF]                        | Indicates that the flash band compensation operation is switched.   |

### Checking and displaying shooting status

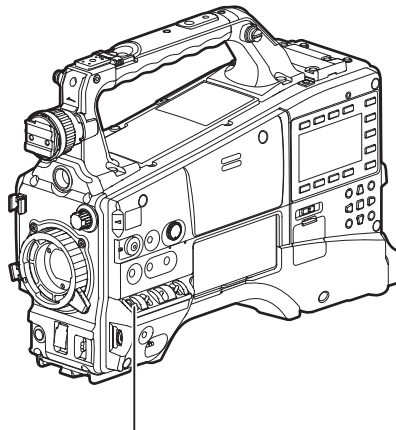

<DISP/MODE CHK> switch

- When the <DISP/MODE CHK> switch is pushed from the <ON> side towards the <CHK> side during recording standby or during recording, all information such as the setting status of the shooting functions, functions assigned to the <USER> buttons (<USER MAIN>/<USER1>/<USER2>) is displayed. Releasing the switch returns the display to the normal display after approximately three seconds.

## Chapter 4 Adjustments and Settings for Recording — Viewfinder status display

- When the <DISP/MODE CHK> switch is pushed towards the <OFF> side during recording standby or during recording, most of the displays are turned off. Set it back to <ON>, the normal display returns.
- Items that are displayed on the viewfinder screen are set when the <DISP/MODE CHK> switch is pushed towards the <CHK> side or the [OTHER DISPLAY] item on the setting menu [DISPLAY SETUP] screen is set.

| No | Display item name   | At item displayed by the mode check<br>✓ | At item that goes out by the display off<br>✓ | Display/hide by setting of [OTHER DISPLAY] item<br>—: Not affected, ✓: Displayed, ×: Goes out |           |       | Can be hidden individually by other menu items<br>—: Not affected |
|----|---|--|---|---|-----------|-------|---|
|    |   |  |   | [ALL]   | [PARTIAL] | [OFF] |   |
| 1  | Time code   | ✓  | Does not go out                               | —   | —         | —     | —   |
| 2  | Warning information   | ✓  | Does not go out                               | —   | —         | —     | —   |
| 3  | HD SDI REMOTE recording status and UPLINK device connection information*8 | ✓  | Does not go out*10                            | —   | —         | —     | —   |
| 4  | Recording format and system mode  | ✓  | ✓   | ✓   | ×         | ×     | —   |
| 5  | Information (center)  | ×  | Does not go out                               | —   | —         | —     | —   |
| 6  | System frequency  | ✓  | ✓   | ✓   | ×         | ×     | —   |
| 7  | Proxy information (option)  | ✓  | Does not go out                               | —   | —         | —     | —   |
| 8  | Letterbox recording   | ✓  | ✓   | —   | —         | —     | —   |
| 9  | Y GET brightness  | ✓  | Does not go out                               | —   | —         | —     | —   |
| 10 | Extender  | ✓  | ✓   | —   | —         | —     | —   |
| 11 | Recommended ND filter   | ✓  | ✓   | ✓   | ✓         | ×     | —   |
| 12 | Date and time   | ✓  | ✓   | —   | —         | —     | [DATE/TIME] item  |
| 13 | Focus bar   | ✓  | Does not go out*1                             | —   | —         | —     | [FOCUS BAR] item  |
| 14 | Shooting/recording and playback frame rate                                | ✓  | ✓   | ✓   | ✓         | ×     | —   |
| 15 | Audio level meter   | ✓  | ✓   | —   | —         | —     | [LEVEL METER] item  |
| 16 | Audio recording not available   | ✓  | ✓   | —   | —         | —     | —   |
| 17 | Shutter speed   | ✓  | ✓   | ✓   | ✓         | ×     | —   |
| 18 | Dynamic range stretcher (DRS) function                                    | ✓  | ✓   | ✓   | ✓         | ×     | —   |
| 19 | Iris  | ✓  | ✓   | ✓   | ✓         | ×     | —   |
| 20 | Auto iris control   | ✓  | ✓   | ✓   | ✓         | ×     | —   |
| 21 | Zoom position   | ✓  | ✓   | —   | —         | —     | [ZOOM/FOCUS] item   |
| 22 | Focus control information   | ✓  | ✓   | —   | —         | —     | [ZOOM/FOCUS] item   |
| 23 | Low-light   | ✓  | ✓   | ✓   | ✓         | ×     | —   |
| 24 | ND filter   | ✓  | ✓   | ✓   | ×         | ×     | —   |
| 25 | Gain  | ✓  | ✓   | ✓   | ✓*2       | ×     | —   |
| 26 | <WHITE BAL> switch position   | ✓  | ✓   | ✓   | ✓*3       | ×     | —   |
| 27 | Ach/Bch color temperature display   | ✓*9                                      | ✓   | ✓*9   | ×         | ×     | [AWB C.TEMP] item   |
| 28 | Flash band compensation (FBC) function                                    | ✓  | ✓   | ✓   | ✓         | ×     | —   |
| 29 | Digital zoom factor   | ✓  | ✓   | —   | —         | —     | —   |
| 30 | Scene file name   | ✓  | ✓   | ✓   | ×         | ×     | —   |
| 31 | Chromatic aberration compensation (CAC) function                          | ✓  | ✓   | —   | —         | —     | —   |
| 32 | Battery charge level  | ✓  | ✓*4   | —   | —         | —     | [CARD/BATTERY] item   |
| 33 | One-clip recording mode status  | ✓  | ✓   | ✓   | ✓         | ×*5   | —   |
| 34 | Media free space  | ✓  | ✓*4   | —   | —         | —     | [CARD/BATTERY] item   |
| 35 | Media information   | ✓  | ✓*6   | ✓   | ✓         | ×*6   | [CARD/BATTERY] item   |
| 36 | Recording/playback operation status                                       | ✓  | ✓*7   | ✓   | ✓         | ×*7   | —   |
| 37 | System tally  | ✓  | Does not go out                               | —   | —         | —     | —   |

\*1 Displayed only on the viewfinder screen

\*2 0 dB is not displayed

\*3 Only [ATW], [LOCK], [P3.2K], [P5.6K], and [VAR\*. \*K] displayed

\*4 Displayed when remaining level is low

\*5 Displayed at start and end of recording of new clip

- \*6 Illuminated by [SLOT SEL] execution
- \*7 Displayed at top right only during recording or in special recording mode
- \*8 For details, refer to the operating instructions of Upgrade Software Key (AG-SFU603G: UPLINK device control function (extra-cost option)).
- \*9 The [AWB C.TEMP] item on the setting menu is displayed when it is [ON]. It is not displayed when it is [OFF].
- \*10 The UPLINK connection information does not disappear even if the display is OFF.

**Mode check display**

Almost all information is displayed in mode check.

**[STATUS] screen**

1 to 6 below are displayed only when the mode check is activated.

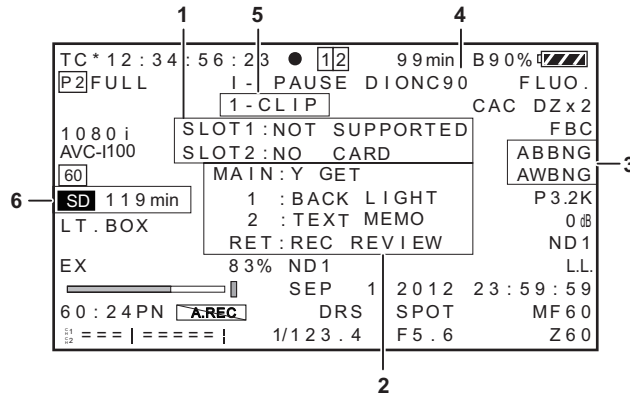

**1 P2 card slot status display**

Displays each of the status of P2 card slots 1 and 2.

|                 |   |
|-----------------|---|
| [ACTIVE]        | Card that can be played back/recorded (including card for recording target) |
| [ACCESSING]     | Card currently being played back/recorded                                   |
| [INFO READING]  | The card is being recognized.   |
| [FULL]          | P2 card with no remaining recording space.                                  |
| [PROTECTED]     | Write-protected P2 card   |
| [NOT SUPPORTED] | Card cannot be used or recognized.  |
| [FORMAT ERROR]  | P2 card not in specified format   |
| [NO CARD]       | No card is inserted.  |
| No display      | In the USB device mode  |

**2 Assignment information display of <USER> buttons (<USER MAIN>/<USER1>/<USER2>) and the <RET> button on the lens**

Displays the information of the functions assigned to the <USER> buttons (<USER MAIN>/<USER1>/<USER2>) or the <RET> button on the lens. For details, refer to “Assigning functions to <USER> buttons” (page 59), “RET SW” (page 124).

**3 Automatic white balance, automatic black balance abnormal display**

Displays the status in the mode check when the automatic white balance and automatic black balance do not function correctly.

**4 Battery type display**

Displays the battery type currently selected for detection of the battery charge level.

**5 One-clip recording mode status display (page 74)**

The display position on the mode check screen is different from the normal screen.

**6 SD memory card remaining space in proxy recording (option)**

Displays the recording capacity when proxy recording is recorded to the SD memory card.

The capacity is displayed in min when it is less than 120 minutes; in h when it is more than 120 minutes; 99h when it is more than 99 hours.

**[PROXY/NETWORK] screen**

The proxy and network operation status can be checked on the [PROXY/NETWORK] status screen for the mode check displayed when the <DISP/ MODE CHK> switch is pushed towards the <CHK> side twice.

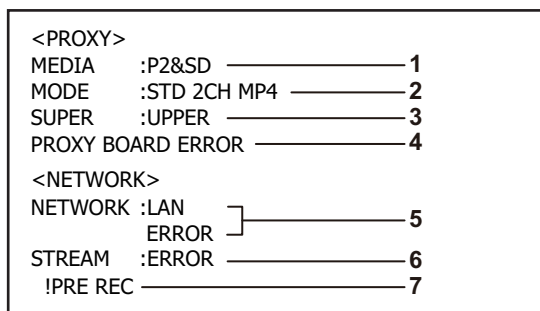

## Chapter 4 Adjustments and Settings for Recording — Viewfinder status display

| Display item |    | Display details  |
|--------------|----|--|
| PROXY        | 1  | [MEDIA]<br>Media selection status for proxy recording<br><b>[P2], [P2&amp;SD], [OFF]</b>   |
|              | 2  | [MODE]<br>Setting status for proxy recording mode<br><b>[STD 2CH MP4], [SHQ 2CH MOV], [HQ 4CH MOV], [HQ 2CH MOV], [LOW 2CH MOV]</b>  |
|              | 3  | [SUPPER]<br>Superimpose setting status for time code<br><b>[UPPER], [LOWER], [OFF]</b>   |
|              | 4  | [PROXY BOARD ERROR]<br>Operation error of proxy interface  |
| NETWORK      | 5  | [NETWORK]<br>Network type and operation status<br><b>[WLAN], [LAN], [OFF]</b><br>• If the selected network is not operated, [ERROR] is displayed at the bottom.  |
|              | 6* | [STREAM]<br>Streaming mode and status display<br>• <b>[RTP]</b> : When RTP mode is selected<br>• <b>[HTTP]</b> : When HTTP mode is selected<br>• <b>[ERROR]</b> : Streaming cannot be activated<br>• <b>[INHIBIT]</b> : When the [STREAMING MODE] item of the menu is set to [INHIBIT] |
|              | 7* | [ERROR] factor of [STREAM]<br>Display the factor why streaming is not activated<br>• <b>[IPROXY MODE]</b> : When proxy setting is not streaming-compatible format<br>• <b>[IPRE REC]</b> : When pre-recording function is turned on and proxy recording is set                         |

\* This is not displayed if the network function is not activated, or if the video encoder board (optional AG-YDX600G) is not installed.

### Center marker display

The [MARKER] item on the setting menu [DISPLAY SETUP] screen is set to [ON].

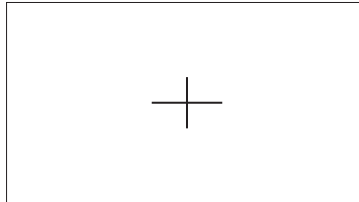





#### NOTE

- The center marker is displayed only in the viewfinder. It is not displayed in the video output and SDI output.

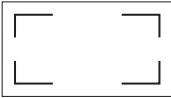
### Safety zone display

The option selected at the [SAFETY ZONE] item on the setting menu [DISPLAY SETUP] screen is displayed.

|        |  |
|--------|--|
| [OFF]  | Does not display.  |
| [90%]  | Displays the range that can be displayed in most household TVs.<br>          |
| [4:3]  | Displays the position after the screen is adjusted by 4:3 aspect ratio.<br>  |
| [13:9] | Displays the position after the screen is adjusted by 13:9 aspect ratio.<br> |
| [14:9] | Displays the position after the screen is adjusted by 14:9 aspect ratio.<br> |

#### NOTE

- When the [SYSTEM MODE] item on the [SYSTEM SETUP] screen is set to [480-59.94i] and [576-50i], and the [ASPECT CONV] item is set to [SIDE CROP] and [LETTER BOX], this is not displayed even by selecting [4:3], [13:9], or [14:9].
- The center zone is displayed only in the viewfinder. It is not displayed in the video output and SDI output.

**Zebra patterns display**

The camera can display two types of zebra patterns.

When the ZEBRA switch of the viewfinder is set to on, the zebra pattern currently set in the menu is displayed on the viewfinder screen.

Zebra patterns can also be displayed in the video of the <MON OUT> terminal according to settings.

The level for displaying zebra patterns can be set on the setting menu [DISPLAY SETUP] screen.

| Item            | Setting value              | Description of settings                                 |
|-----------------|----------------------------|---|
| [ZEBRA1 DETECT] | [50%] ... [70%] ... [109%] | Sets the level of zebra pattern 1 tilting to the right. |
| [ZEBRA2 DETECT] | [50%] ... [85%] ... [109%] | Sets the level of zebra pattern 2 tilting to the left.  |
| [ZEBRA2]        | [ON], [SPOT], [OFF]        | Selects the type of [ZEBRA2].                           |

Underlined settings are factory settings.

[SPOT]: The video level from the setting value of [ZEBRA1] to the setting value of [ZEBRA2] is displayed in the zebra pattern.

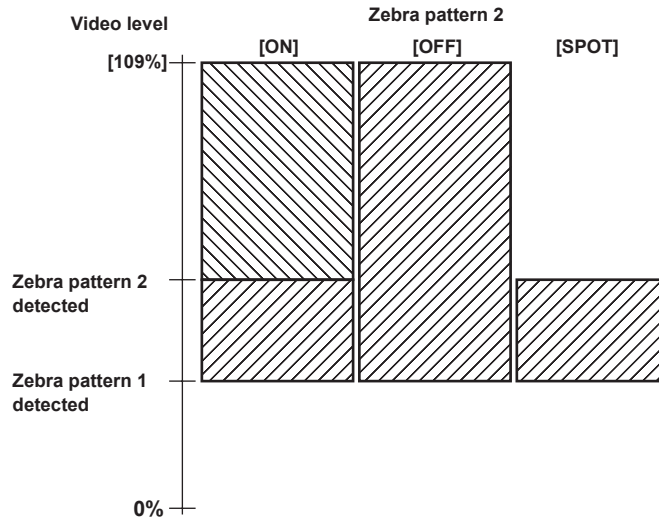

To display the zebra pattern on the video for the <MON OUT> terminal, set the [MON/HDMI ZEBRA] item on the setting menu [IN/OUT SEL] screen or the [SET03:MON/HDMI SETUP] item of SmartUI.

**Focus assist function**

An enlarged area and focus bar can be displayed to make focusing easier.

|                                    |   |
|------------------------------------|---|
| <b>Enlarged area</b><br>[EXPANDED] | Press the <FOCUS ASSIST> button to enlarge the central area of the screen by approximately 3x to make it easier to focus. |
|------------------------------------|---|

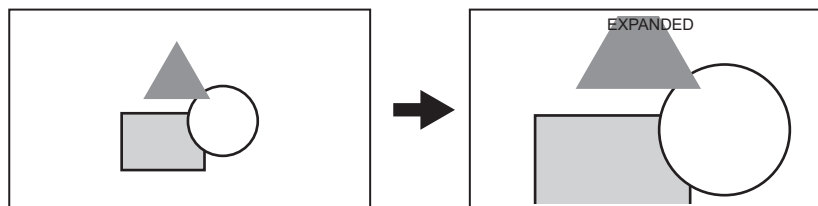
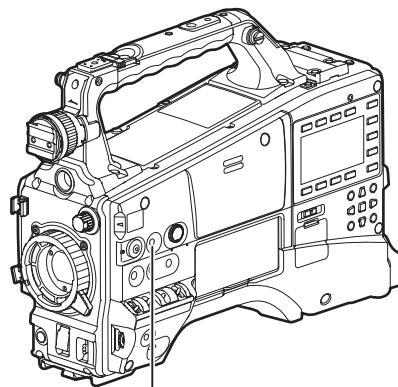

- In the enlarged display, the status display and zebra pattern disappear, and [EXPANDED] is displayed at the top of the screen.

**NOTE**

- Only the viewfinder screen is displayed enlarged.



- The display is not enlarged with video output, SDI output, and HDMI output, but the status display disappears when various statuses are displayed.

|  |   |
|--|---|
| <b>Focus bar display</b><br><b>[FOCUS BAR]</b> | The focus bar is displayed when the [FOCUS BAR] item on the setting menu [DISPLAY SETUP] screen is set to [ON].<br>The degree of focus is indicated by the length of the bar. |
|--|---|

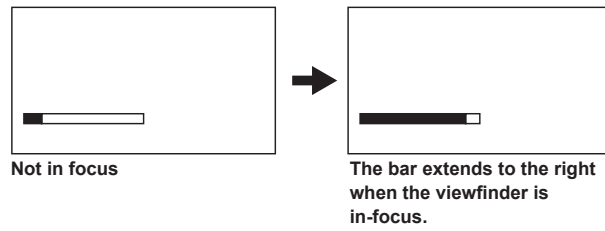

### Waveform monitor function

A waveform of the video can be displayed by assigning the waveform monitor function to the <USER> buttons (<USER MAIN>/<USER1>/<USER2>) and pressing the assigned <USER> buttons (<USER MAIN>/<USER1>/<USER2>). Press the button again to return to the normal display.

- The waveform and vector displays can be switched by the [WFM] item (page 124) on the setting menu [SW MODE] screen.
- This is not displayed while the focus assist function [EXPANDED] is activated.
- The waveform display cannot be recorded.

## Handling setting data

### Setting data file configuration

F1 to F6 scene files can be saved internally on the camera matched to scene file numbers.

When an SD memory card is used, a maximum of four data of F1 to F6 can be batch-saved to files in the card for reading and use later on.

Also, one set of setting menu values (including SmartUI setting values) can be saved internally on the camera as a user file, and up to four sets can be saved to an SD memory card.

The figure below shows the configuration of setting data files on the camera.

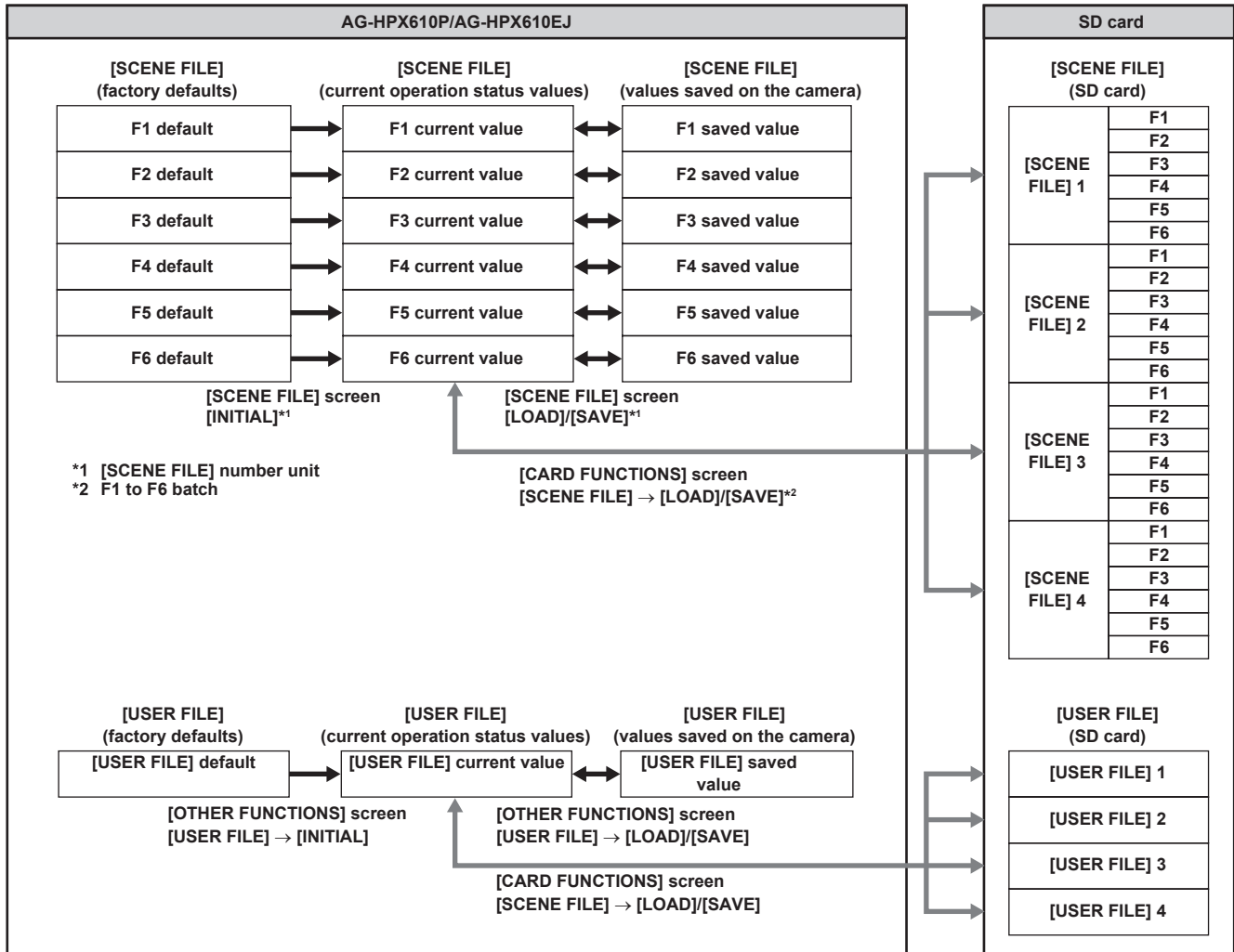

### NOTE

- When the [MENU INIT] item on the setting menu [OTHER FUNCTIONS] screen is executed, all current operation status values and values saved on the camera of F1 to F6, and the current operation status values and values saved on the camera in user files can be batch-returned to factory defaults. However, [TIME ZONE] settings cannot be returned to factory defaults.
- Operations on setting data files may result in error during playback or when the [PC MODE] item on the setting menu [PC/USB/LAN] screen is set to [ON]. Set the [PC MODE] item to [OFF] before performing operations.
- When recording is possible by combining to the previous clip by one-clip recording (i.e. when [1\*CLIP] is displayed), operations cannot be performed on scene files or user files. Close the menu and press the <STOP> button for approximately two seconds to stop combining to the clip, and try the operations again.

### Setting up using SD memory cards

An SD or SDHC memory card (optional) can be used as a setup card that stores up to four files of setting menu content.

Use of this data allows you to quickly reproduce optimum setup states.

### Handling SD memory cards

The SD memory card can be removed and inserted, either before or after the power is turned on.

### Inserting SD memory cards

Open the slot cover, insert the card into the SD memory card slot with the label side of the SD memory card (optional) upward, and close the slot cover.

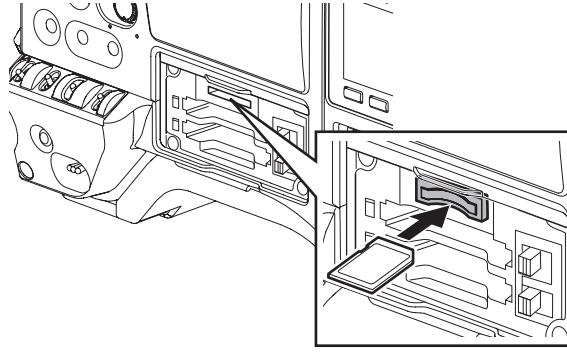

### NOTE

- The SD memory card must be inserted with the correct side facing the SD card slot. If the SD memory card is hard to insert, it may be reversed or upside-down. Do not force it into the slot. Check the orientation of the card before re-inserting it.
- On the camera, use SD memory cards that are compliant with the SD standard or the SDHC standard.
- For details on handling SD memory cards, refer to “Cautions in using SD memory cards” (page 25).

### Removing SD memory cards

After opening the slot cover and making sure that the busy lamp is not illuminated, push the SD memory card further into the main unit and then release. This releases the SD memory card from the card slot, and remove the SD memory card and close the slot cover.

### Note the following points when using or storing memory cards.

- Avoid high temperature and humidity
- Avoid water droplets
- Avoid charging with electricity

Store the SD memory card with the card still inserted into the camera and with the slot cover closed.

### Performing operations on SD memory cards

Perform operations such as formatting an SD memory card, write setting data to an SD memory card, or read data on a memory card on the setting menu [CARD FUNCTIONS] screen.

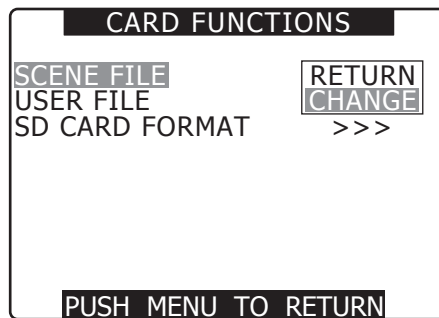

If the SD memory card that is formatted in a standard other than the SD/SDHC standards on a device other than the camera is inserted, [FORMAT ERROR] is displayed at the top right of the screen. In this case, reformat the SD memory card.

### Formatting SD memory cards

### NOTE

- SD memory cards can also be formatted from the thumbnail screen. For details, refer to “Formatting SD memory cards” (page 111).

**1** Select the [SD CARD FORMAT] item on the setting menu [CARD FUNCTIONS] screen, and press the jog dial button.

For details, refer to “Setting menu basic operations” (page 116).

**2** Select [EXECUTE], and press the jog dial button.

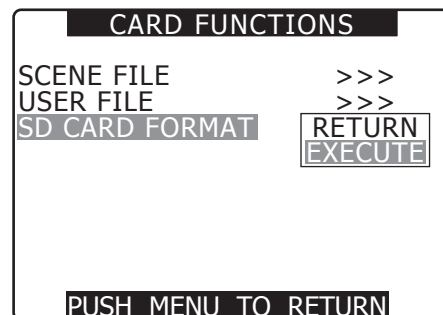

**3** Select [YES] on the confirmation screen, and press the jog dial button.

[SD CARD FORMAT OK] is displayed, and the SD memory card is formatted.

**NOTE**

- Since data that is deleted by formatting cannot be restored, be sure to check the data before executing formatting.
- The card will not be formatted if the following message is displayed while the jog dial button is pressed:

| Error message   | Remedy  |
|---|---|
| [SD CARD FORMAT NG NO CARD]<br>(No SD memory card is inserted.)     | Insert an SD memory card.   |
| [SD CARD FORMAT NG ERROR]<br>(The card cannot be formatted.)        | The SD memory card may be defective.<br>Replace the card.                                       |
| [SD CARD FORMAT NG WRITE PROTECT]<br>(The card is write-protected.) | Remove the SD memory card and cancel the protection.  |
| [SD CARD FORMAT NG CANNOT ACCESS]<br>(The card cannot be accessed.) | The SD memory card cannot be accessed.<br>Wait for accessing to end and then reformat the card. |

**How to use scene file data**

- Settings matching various shooting conditions can be saved as individual scene file numbers.
  - The required files can be read in the [CAM02:SCENE FILE] screen of SmartUI.
  - The setting values of scene files can also be changed at each item of the setting menu (page 120). After a scene file is changed, it can also be saved as individual scene file numbers.
  - Even when the [VFR] item (option) and the [F.RATE] item (option) are switched on SmartUI during recording, operation is not changed. The operation changes after recording completes.
- Same applies when the [VFR] item or the [F.RATE] item is changed by switching between [F1] to [F6] of scene files.

**Factory settings**

|                |  |
|----------------|--|
| [F1]           | File suitable for standard shooting  |
| [F2]: [FLUO.]  | File suitable for shooting factoring in the characteristics of fluorescent lighting (e.g. indoor shooting) |
| [F3]: [SPARK]  | File suitable for SD shooting with resolution, hue and contrast enhanced                                   |
| [F4]: [B-STR]  | File suitable for shooting with shadow tones extended (e.g. sunsets)                                       |
| [F5]: [CINE V] | File suitable for film-like shooting with priority given to contrast                                       |
| [F6]: [CINE D] | File suitable for film-like shooting with priority given to dynamic range                                  |

**NOTE**

- The [SYSTEM MODE] item is not changed even if a scene file is changed. Set this at each item on the setting menu [SYSTEM SETUP] screen.

**Changing scene file settings**

**Renaming scene files**

**1** Use the <CAM> button to display the [CAM02:SCENE FILE] screen of SmartUI, and select the scene file to be changed.

**2** Select the [NAME EDIT] item on the setting menu [SCENE FILE] screen, and press the jog dial button.

For details, refer to “Setting menu basic operations” (page 116).

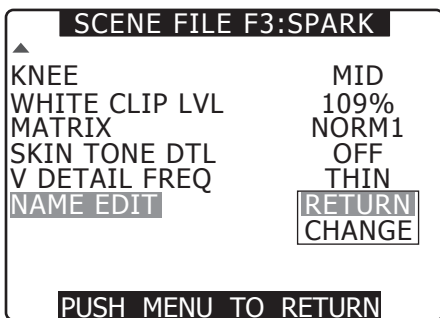

**3** Select [CHANGE], and press the jog dial button.

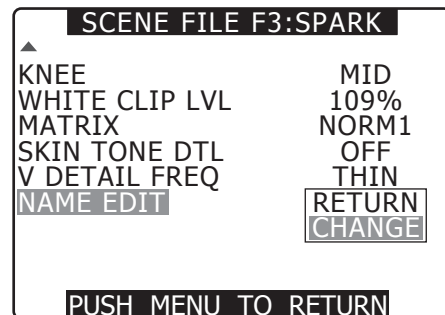

**4** When the following screen is displayed, use the jog dial button to set a 6-character file name.

- Turning the jog dial button switches the character display in the order of space ( ) → alphabet characters (A to Z) → numbers (0 to 9) → symbols (:;<=>?@[¥]^\_-.).

- When a file name is already set, pressing the <RESET> button while the file name is being set clears the characters.

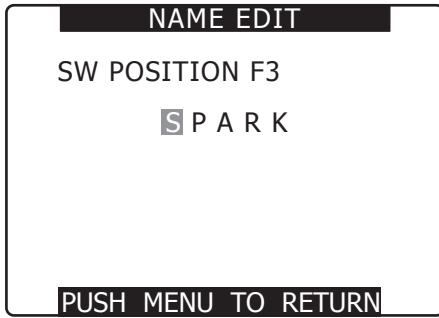

- Pressing the <MENU> button ends [NAME EDIT]. When the changed value is fixed, it is held even if the power is turned off or the dial position is changed. The settings of each item for the scene file are also held in the same way.

■ Saving F1 scene data to the camera

**1** Select the [LOAD/SAVE/INIT] item on the setting menu [SCENE FILE] screen, and press the jog dial button.

For details, refer to “Setting menu basic operations” (page 116).

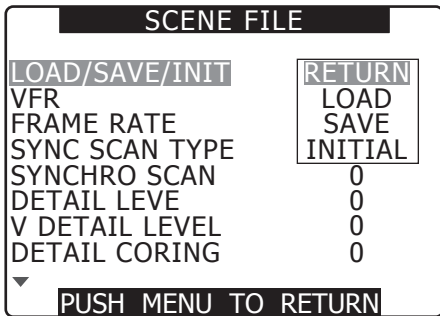

- To return to the setting menu one up the menu hierarchy, press the <MENU> button.

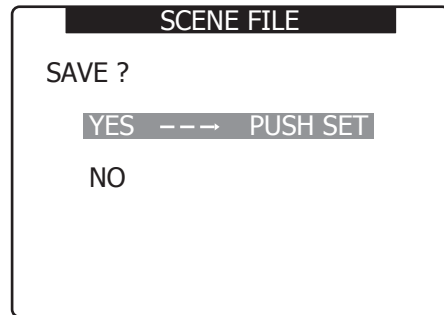

**2** Select [SAVE], and press the jog dial button.

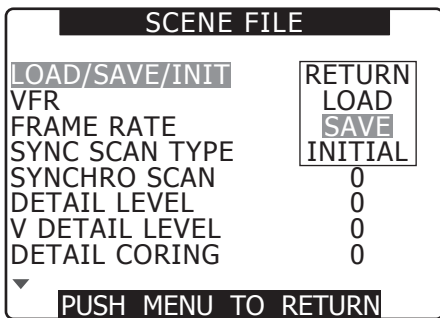

- When changes to settings ends after [PROCESSING...] is displayed, the following message is displayed:



**3** Select [YES], and press the jog dial button.

- To return settings to their previously saved values after scene file settings have been changed, select [LOAD] in step 2, and perform step 3 in the same way.
- To return scene file settings to factory settings, select [INITIAL] in step 2, and perform step 3 in the same way.
- To save and read user file settings, and return settings to their factory settings, perform the same operation as for scene files at the [USER FILE] item on the setting menu [OTHER FUNCTIONS] screen.

**Saving scene files, etc. to SD memory cards**

Up to four each of scene files that have been set or other setting values can be grouped together and saved on or read from SD memory cards.

- With scene files, current setting values are automatically saved on the camera, and that saved data is written to the SD memory card. When data is read from an SD memory card, the current setting values are rewritten at the same time as data saved internally on the camera.
- All scene files of F1 to F6 are rewritten. For details on handling SD memory cards, refer to “Handling SD memory cards” (page 82).

The following basically explains how to save scene files.

**1** Select the [SCENE FILE] item on the setting menu [CARD FUNCTIONS] screen, and press the jog dial button.

For details, refer to “Setting menu basic operations” (page 116).

**2** Select [CHANGE], and press the jog dial button.

To select other setting values, select [USER FILE].

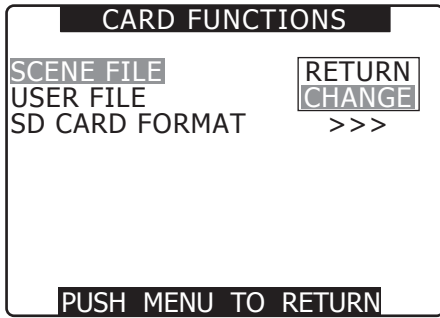

**3** Press and turn the jog dial button to select the file number (1 to 4).

To apply a setting, press the jog dial button again.

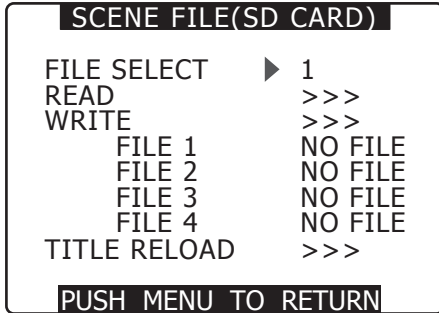

**4** Select [WRITE], press the jog dial button, and select [EXECUTE], and then press the jog dial button.

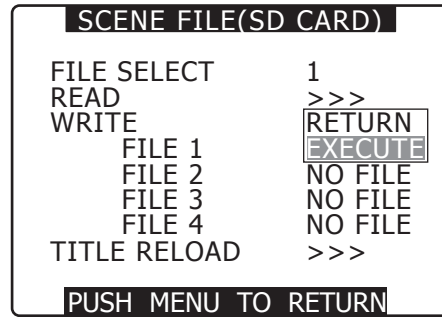

**5** Press the cursor buttons, turn the jog dial button, and select [YES], and then press the jog dial button.

- In the figure below, [TITLE1] is the file name.
- [WRITE OK] is displayed when writing is complete.

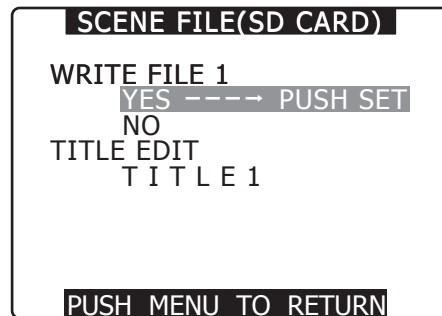

### Reading files

Perform steps 1 to 3, select [READ] in step 4, and select [EXECUTE], and then press the jog dial button. [READ OK] is displayed when reading is complete.

For user files, perform the same operation as for scene files at the [USER FILE] item on the [CARD FUNCTIONS] screen.

### Re-reading files from an SD memory card

Perform steps 1 to 2, select [TITLE RELOAD] in step 4, and select [YES], and then press the jog dial button to re-read the file.

### Adding titles to files

**1** Perform steps 1 to 4.

**2** Turn the jog dial button, select the desired character, and press the jog dial button to move to the next character.

- Space ( ), alphabet character (A to Z), numbers (0 to 9), symbols (:;<=>?@[¥]^\_./)
- You can clear all characters by the <RESET> button.

**3** When you have finished entering all characters, move the cursor to the right end of the entered title.

**4** Select [YES], and press the jog dial button.

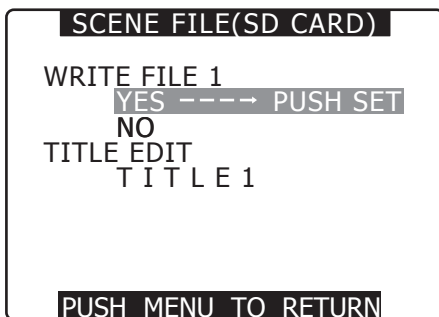

[WRITE OK] is displayed when writing is complete.

### NOTE

- If [WRITE NG FORMAT ERROR] is displayed, reformat the SD memory card.
- If [WRITE NG WRITE PROTECT] is displayed, cancel the protection of the SD memory card.
- If [WRITE NG CANNOT ACCESS] appears, quit all other operations (such as playback) before proceeding.
- When [WRITE NG ERROR] is displayed, a probable cause is a defective SD memory card, so replace the memory card.

## Chapter 5 **Preparation**

---

Before you use the camera, mount the battery and lens following the procedures in this chapter. The mounting of accessories is also described in this chapter.

## Power supply

A battery or an external DC power supply can be used as power supply.

### Using batteries

Batteries with validated connection with the camera are as follows.

#### ■ Anton/Bauer batteries

HYTRON50, HYTRON140  
DIONIC90, DIONIC160, DIONIC HC

#### ■ IDX batteries

ENDURA7, ENDURA10, ENDURA HL9

#### ■ PAG batteries

PAG L96e

#### NOTE

- Other batteries may be supported by changing the setting menu, but we recommend that you use batteries with connection to the camera validated.
- Before you use a battery, charge it with a battery charger. (For details on charging, refer to each instruction operation.)

### Mounting and setting battery

#### Using Anton/Bauer batteries

##### 1 Mount an Anton/Bauer battery.

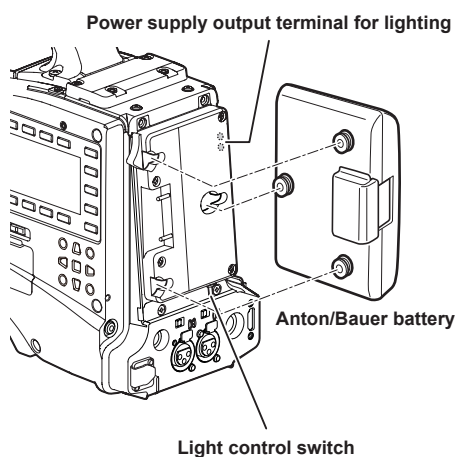

#### NOTE

- The Anton/Bauer battery holder includes both a power supply output terminal for lighting and a light control switch, which are convenient when installing light. Contact Anton/Bauer, Inc. for details on lighting systems.

##### 2 Insert the battery, and slide it in the direction of the arrow.

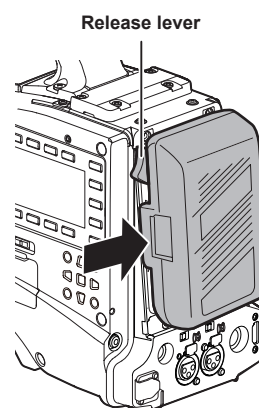

#### NOTE

- To remove the battery, keep the release lever of the battery holder completely down, slide the battery in the opposite direction of when you mounted it.

##### 3 Set the battery type.

Set the battery type with the [BATTERY SELECT] item on the setting menu [BATTERY SETUP] screen.  
For details, refer to “Setting menu basic operations” (page 116).

#### Using V-mount type batteries

Mount the V-mount adaptor plate. As shown in the figure, insert and slide in the direction of the arrow.

- When removing the plate, remove by sliding the release lever.

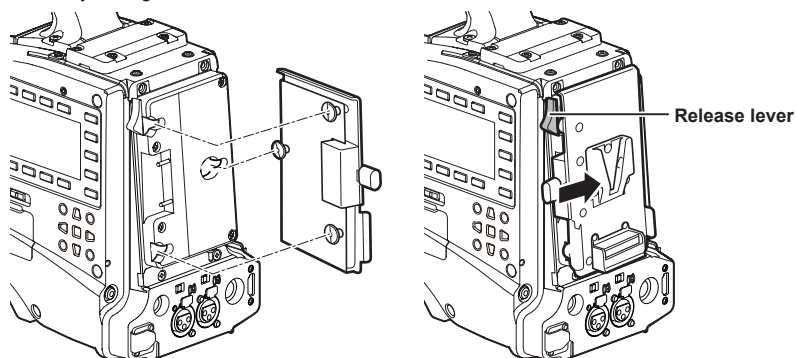



■ **Setting the battery type**

- Set the battery type with the [BATTERY SELECT] item on the setting menu [BATTERY SETUP] screen.
- When using a battery that is not in the [BATTERY SELECT] item, set [TYPE A] or [TYPE B], and set each item according to the characteristics of the battery. (The default value of [TYPE A] is set to ENDURA HL9 of the IDX battery.)  
For details, refer to “[BATTERY SETUP] screen” (page 128).

 **NOTE**

- Contact the point of purchase for information about the V-mount adaptor plate.
- When the V-mount adaptor plate is used, % (percent) display is not possible even if batteries with battery level indicator function are used.

**Using NP type batteries**

**1 Mount the V-mount adaptor plate onto the camera.**

For details, refer to “Using V-mount type batteries” (page 88).

**2 Mount the holder plate onto NP type battery case.**

- When packing comes with the holder plate, apply the packing to the battery case beforehand.

- 1) Remove the screw on the bottom of the cover, and remove the cover.
- 2) Align the holes in the battery case and the holder plate, and tighten the mounting screw.
- 3) Tighten the screw for power supply contact.
- 4) Insert the top of the removed cover in the direction of the arrow.

- 5) Align holes on the bottom of the cover (metal part) with holes on the case and mount with the screw.

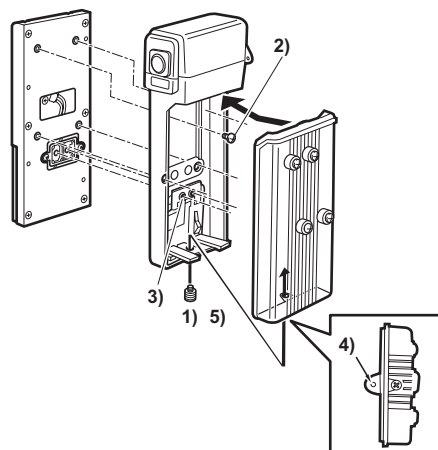

**Using external DC power supply**

**1 Connect the external DC power supply to the <DC IN> terminal of the camera.**

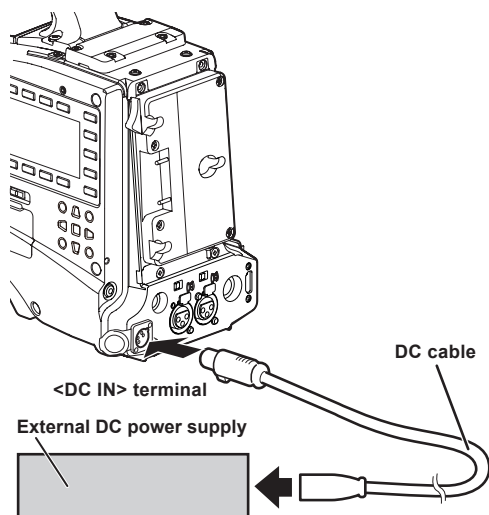

**2 Turn on the external DC power supply switch (if there is an external DC power supply switch).**

**3 Turn the <POWER> switch of the camera <ON>.**

■ **External DC power supply**

Connect after making sure that the output voltage of the external DC power supply is compatible with the rated voltage of the camera. Select an output amperage for the external DC power supply with a margin above the total amperage of the connected devices. The total amperage of connected devices can be calculated with the following formula.

Total power consumption ÷ Voltage

When the power of the camera is turned on, inrush current is generated. Insufficient power supply when turning on the power may cause a malfunction. We recommend using an external DC power supply that can assure double the capacity of the total power consumption of the camera and connected devices that are turned on by interlock when the power of the camera is turned on (such as lenses, wireless microphone receivers). For the DC cable, use a dual-core shielded wire of AWG18 (nominal cross section area 0.824 mm<sup>2</sup>) or thicker.

- Make sure of the pin alignment of the DC output terminal of the external DC power supply and the camera <DC IN> terminal, and connect the polarity correctly.  
If the +12 V power supply is connected to the GND terminal in error, it may cause fire or malfunction.

| DC IN |       |
|-------|-------|
| 1     | GND   |
| 2     | NC    |
| 3     | NC    |
| 4     | +12 V |

Panasonic Parts No: K1AA104H0038

Manufacturer Parts No: HA16RX-4P (SW1) (76) (Hirose Electric Co.)

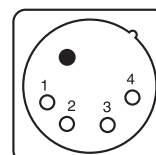

 **NOTE**

- When both the battery and the external DC power supply are connected, the power supply from the external DC power supply has priority. The battery may be removed while using the external DC power supply.
- When using an external DC power supply, always turn the power switch of the external DC power supply on before turning the <POWER> switch of the camera <ON>. If the operations are performed in reverse, the camera may malfunction because the external DC power supply output voltage rises too slowly.
- When connecting batteries to the <DC IN> terminal, set to [BATTERY] with the [EXT DC IN SEL] item on the setting menu [BATTERY SETUP] screen, and set the battery type with the [BATTERY SELECT] item. However, in that case, % display is not possible for batteries with battery level indicator function.

## Mounting and adjusting the lens

### Mounting the lens

- 1** Raise the lens lever and remove the mount cap.

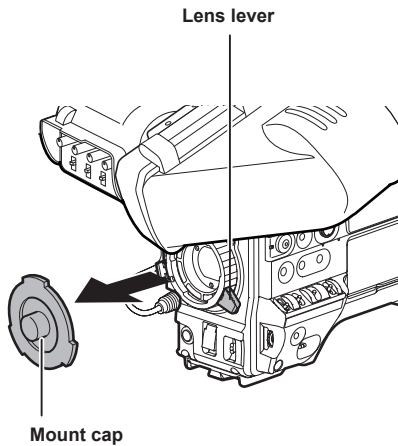

- 2** Align the indentation at the top center of the lens mount with the center mark of the lens to mount the lens.

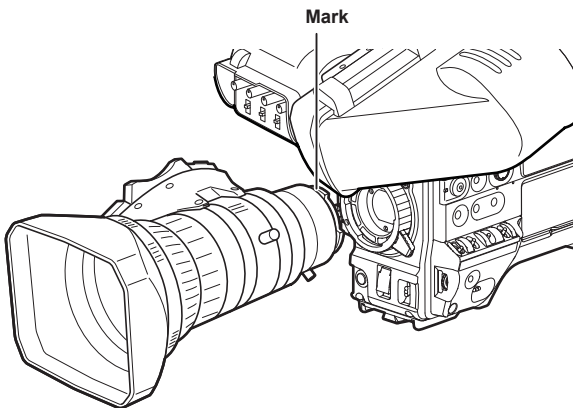

- 3** Lower the lens lever to firmly clamp the lens.

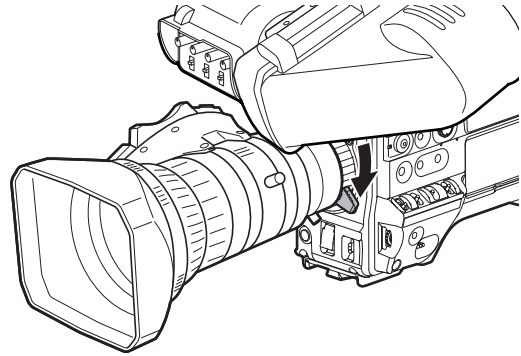

- 4** Secure the cable through the cable clamp and connect it to the <LENS> terminal.

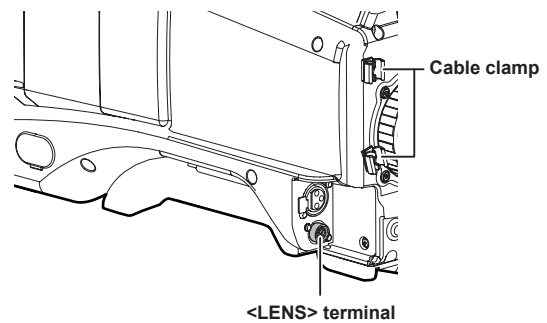

#### **NOTE**

- For details on the current from the <LENS> terminal, refer to “Details of the connector signals” (page 173).

- 5** Perform lens flange back adjustments.

For details, refer to “Flange back adjustment” (page 91).

#### **NOTE**

- For handling the lens, refer to the lens operating instructions.
- When the lens is removed, install the mount cap to protect the device.

### Flange back adjustment

If images are not clearly focused at both telephoto and wide-angle positions during zoom operations, adjust the flange back (distance from the lens mounting surface to the image formation surface).

Once adjusted, the flange back does not need to be readjusted as long as the lens is not changed.

#### **NOTE**

- Refer to the lens operating instructions for guidance on adjustment methods and positions of lens parts.

### For a normal lens

- 1** Mount the lens on the camera.

Make sure to connect the lens cable.

- 2** Set the lens iris to manual, and fully open the iris.

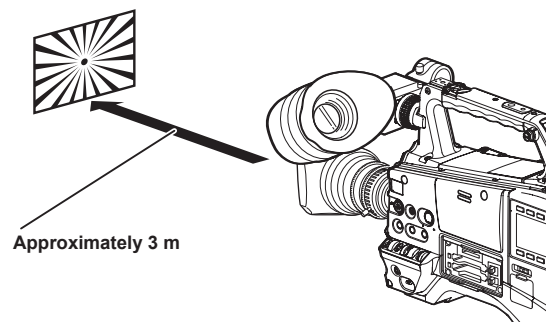

- 3** Place the flange back adjustment chart approximately 3 m from the lens and adjust the lighting on the chart to obtain an appropriate image output level.

If the image level is too high, use the filters or the shutter.

- 4** Loosen the F.f (Flange focus) ring clamping screw.

**NOTE**

- F.b (Flange back) may be indicated on some lenses.

- 5** Set the zoom ring to the telephoto position, either manually or by electric drive.

- 6** Aim the lens at the flange back adjustment chart and turn the distance ring to bring the chart into focus.

- 7** Set the zoom ring to the wide-angle position and turn the F.f (Flange focus) ring to bring the chart into focus.

At this time, do not move the distance ring.

- 8** Repeat steps 5 to 7 until the lens is in focus at both the telephoto and wide-angle positions.

- 9** Firmly tighten the F.f (Flange focus) ring clamping screw.

**White shading compensation**

Three optionally adjustable data items [USER1], [USER2], and [USER3] can be used for white shading compensation with the camera. Set these data items from the [SHADING SELECT] item on the setting menu [LENS SETUP] screen. Shading compensation is not performed when set it to [OFF].

**NOTE**

- When white shading adjustment is performed while image is being disturbed due to the generator lock, adjustment may not be performed correctly. Try white shading adjustment again after the image returns to normal.

**Selecting white shading data**

- 1** Select the [SHADING SELECT] item on the setting menu [LENS SETUP] screen, and press the jog dial button.

For details, refer to “Setting menu basic operations” (page 116).

- To perform white shading adjustment, select either [USER1], [USER2], or [USER3].
- With factory settings, no data is stored in [USER1], [USER2], and [USER3].

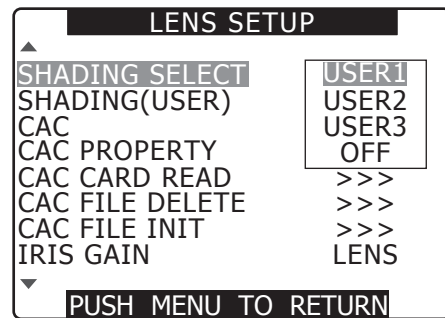
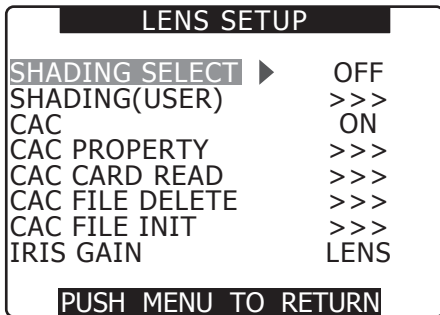

- 2** Use the jog dial button to select any one of [USER1], [USER2], [USER3], or [OFF], and press the jog dial button.

**Adjusting the white shading**

**NOTE**

- Coloring may occur in the vertical direction near where the lens aperture is open (OPEN) even when the white shading has been adjusted, but this is something that is inherent to optical systems and is therefore not indicative of a malfunction.

- 1** Set the camera for adjustment.

- 1) Mount the lens on the camera.
  - Make sure to connect the lens cable.
- 2) Set the shutter switch to OFF and the gain to 0 dB.
- 3) If the lens is equipped with extender function, release the extender function.
- 4) Check that either [USER1], [USER2], or [USER3] is set with the [SHADING SELECT] item on the setting menu [LENS SETUP] screen.
- 5) Select [EXECUTE] at the [SHADING (USER)] item, and press the jog dial button.

- The [CHECK LUMINANCE LEVEL ZEBRA ON EVF] message appears.

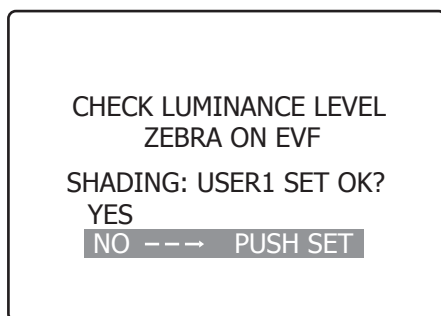
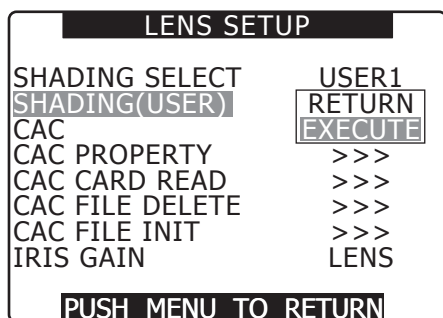

## 2 Set the screen.

- 1) Shoot a white sheet of paper with no unevenness of color for the whole screen.
- 2) Set the lens aperture control to manual, and adjust it so that the zebra pattern covers the whole viewfinder screen.
  - Adjust the position of the lighting because the zebra pattern will not cover the whole screen if there is any unevenness in the lighting.
  - Make adjustments to avoid several light sources of different color temperature (e.g. fluorescent lights and halogen lamp) from illuminating on the white paper.

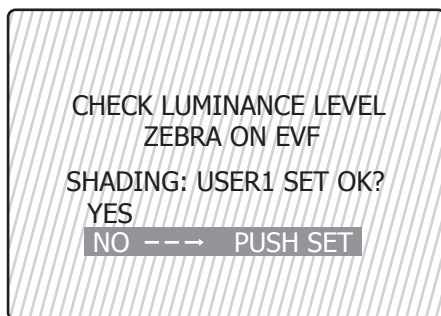

## NOTE

- Since fluorescent lights, mercury lamps, and other such kinds of lighting tend to flicker, use a light source which is less subject to flickering such as sunlight or a halogen lamp.
- Make adjustments to the position of the lighting, etc. also when the lens aperture is not between F4 and F11.
- Make sure to leave the shutter switch at OFF.

## 3 Adjust the white balance/black balance.

- 1) Set the <WHITE BAL> switch to <A> or <B>, and use the <AUTO W/B BAL> switch to perform automatic white balance adjustment (AWB).
- 2) Perform automatic black balance adjustment (ABB) with the <AUTO W/B BAL> switch.
- 3) Use the <AUTO W/B BAL> switch to perform automatic white balance adjustment (AWB) again.

## 4 Perform step 2-2) again.

## 5 Execute the white shading adjustment.

- 1) Select [YES], and press the jog dial button.
- 2) The [SHADING ACTIVE] message appears on the screen during the adjustment.
- 3) When the adjustment is complete after a few seconds, the [SHADING OK] message appears.

- If an error message such as [SHADING NG LEVEL OVER] or [SHADING NG LOW LIGHT] appears, readjust the aperture.
- The adjusted value is automatically stored in the set memory [USER1], [USER2], or [USER3].

## 6 If the lens is equipped with extender function, turn on the extender function and repeat steps 2 to 5.

In this case, white shading does not need to be adjusted again with the extender function released.

## Chromatic aberration compensation function (CAC)

The chromatic aberration compensation function is a function to automatically compensate for registration error that is caused mainly due to slight chromatic aberration, which is hard to completely compensate with the lens itself, using the camera recorder unit, and to minimize lateral chromatic aberration of surrounding image.

When the lens compatible with the chromatic aberration compensation function is mounted, if the camera has the chromatic aberration compensation data of the lens, then the chromatic aberration compensation function is activated automatically.

## NOTE

- In the menu, representative lens model numbers are displayed.
- The chromatic aberration compensation function of the camera is effective only in the horizontal direction.
- The chromatic aberration compensation function does not operate in +18 dB.
- When the lens is for macro shooting, the chromatic aberration compensation function may not operate correctly.
- For addition or change in compatible lenses after release of the camera, visit the support desk at the following website:  
<http://pro-av.panasonic.net/>

## Confirming the chromatic aberration compensation function operation status

The chromatic aberration compensation function is operating if [CAC] is displayed on the upper right of the mode check screen while the menu is not displayed.

Confirming the chromatic aberration compensation data number and information

- 1 Select the [CAC PROPERTY] item on the setting menu [LENS SETUP] screen, and press the jog dial button.

For details, refer to “Setting menu basic operations” (page 116).

- 2 Select [DISPLAY], and press the jog dial button.

The properties of the chromatic aberration compensation function are displayed.

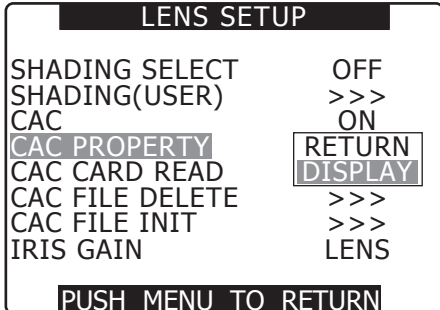

- Chromatic aberration compensation function properties (example)

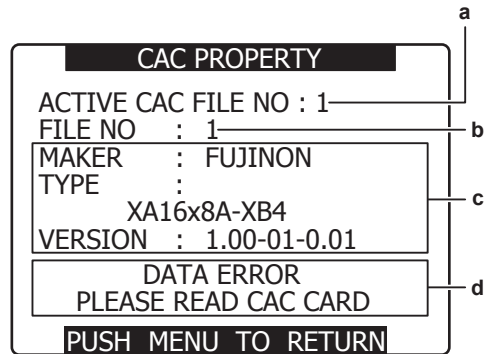

- a: Data number of chromatic aberration compensation currently in use
- b: Data number of chromatic aberration compensation to be confirmed  
Select by turning the jog dial button.
- c: Information of chromatic aberration compensation data specified in b
- d: Error message  
The file cannot be used if an error message is displayed. Perform either initialization of the chromatic aberration compensation file, or read the chromatic aberration compensation file from the SD memory card again.  
For details, refer to “Reading the chromatic aberration compensation file from the SD memory card” (page 94), “Initializing the chromatic aberration compensation file (returning to the factory settings)” (page 95).

Reading the chromatic aberration compensation file from the SD memory card

- 1 Select the [CAC CARD READ] item on the setting menu [LENS SETUP] screen, and press the jog dial button.

For details, refer to “Setting menu basic operations” (page 116).

- 2 Select [EXECUTE], and press the jog dial button.

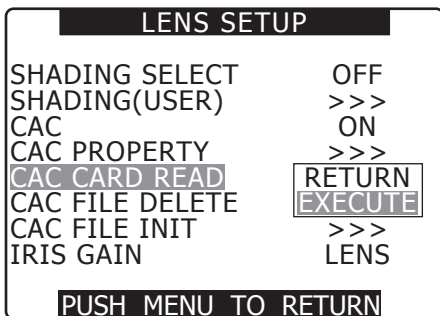

- 3 Select the chromatic aberration compensation file to be read, select [YES] on the confirmation screen, and then press the jog dial button.

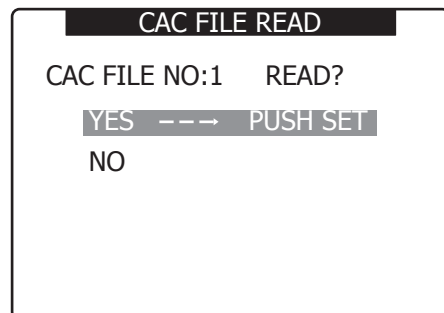
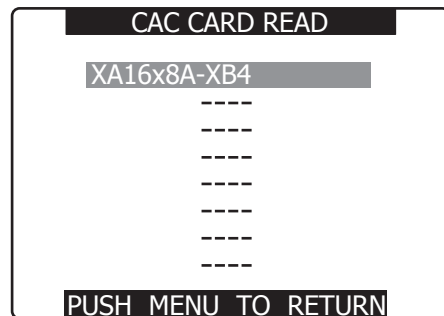

**NOTE**

- Up to eight files can be read into the camera.  
If you try to read a file when eight files have already been read into the camera, [READ NG CAC FILE FULL] is displayed. To read a new file, delete any file before reading the new file.

For details, refer to “Deleting the chromatic aberration compensation file from the camera” (page 95).

- When [READ NG FORMAT ERROR] is displayed, the file is unusable and cannot be read. Make sure that the file can be used with the camera, or the file is correctly stored in the SD memory card.

**Deleting the chromatic aberration compensation file from the camera**

- 1 Select the [CAC FILE DELETE] item on the setting menu [LENS SETUP] screen, and press the jog dial button.

For details, refer to “Setting menu basic operations” (page 116).

- 2 Select [EXECUTE], and press the jog dial button.

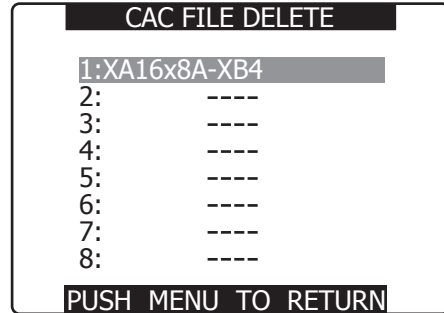
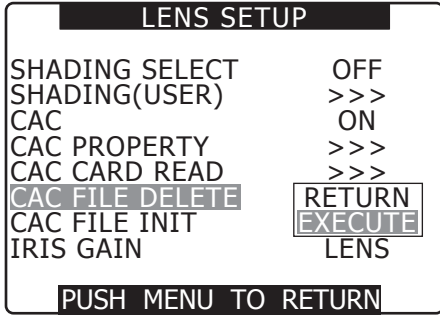

- 3 Select the chromatic aberration compensation file to be deleted, select [YES] on the confirmation screen, and then press the jog dial button.

The display changes to [----] when deletion is complete.

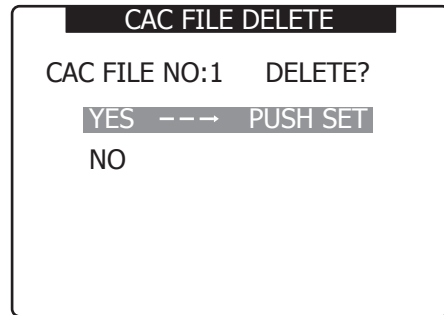

**Initializing the chromatic aberration compensation file (returning to the factory settings)**

- 1 Select the [CAC FILE INIT] item on the setting menu [LENS SETUP] screen, and press the jog dial button.

For details, refer to “Setting menu basic operations” (page 116).

- 2 Select [EXECUTE], and press the jog dial button.

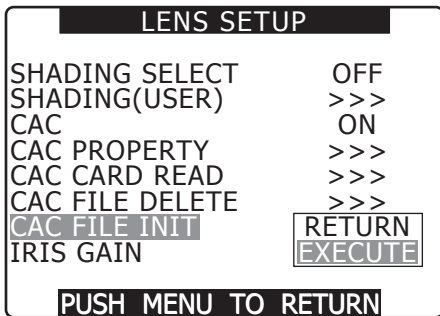

**NOTE**

- This operation deletes all the files read on the camera, and restores a single chromatic aberration compensation file of the factory setting.

- 3 Select [YES] on the confirmation screen, and press the jog dial button.

- Initialization is complete when [CAC FILE INIT] → [PROCESSING...] → [COMPLETED] (these three items are displayed in order) are displayed.
- When completed, the display returns to the [LENS SETUP] screen.

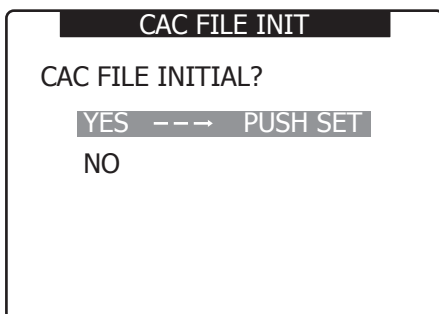

## Preparing for audio input

Prepare the camera for connecting audio input devices.

### Using the front microphone

Microphones such as the microphone kit AG-MC200G (optional) can be mounted.

**1** Open the microphone holder.

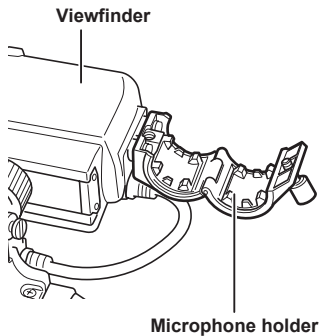

**2** Mount the microphone and tighten the clamping screw.

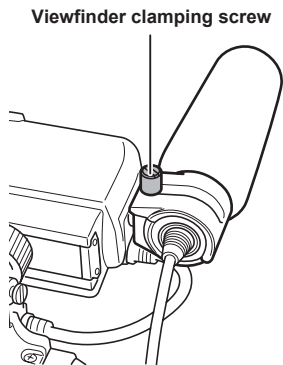

**3** Connect the microphone cable to the <MIC IN> terminal on the camera.

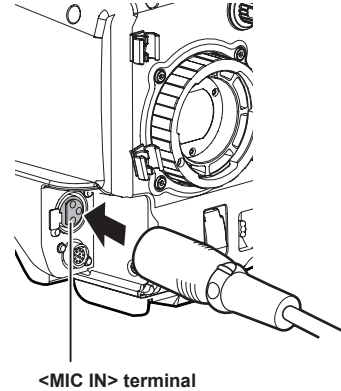

**4** According to the audio channel to be recorded, switch the input signal to [FRONT] on the [AUD02:INPUT] screen of SmartUI.

| AUD02:INPUT |         | [CH3/4] |         |
|-------------|---------|---------|---------|
| CH1         |         | CH2     |         |
| FRONT       |         | FRONT   |         |
| W.L.        | AUTO    | W.L.    | AUTO    |
| REAR        | MANU    | REAR    | MANU    |
| [ IN ]      | [ LVL ] | [ IN ]  | [ LVL ] |

### Using a wireless receiver

**1** Remove the cover to insert the wireless receiver and secure it with the screws.

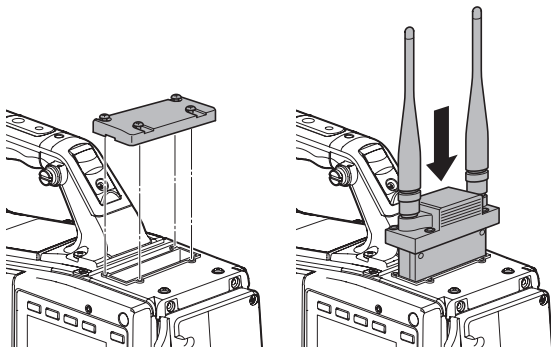

**2** According to the audio channel to be recorded, switch the input signal to [W.L.] on the [AUD02:INPUT] screen of SmartUI.

| AUD02:INPUT |         | [CH3/4] |         |
|-------------|---------|---------|---------|
| CH1         |         | CH2     |         |
| FRONT       |         | FRONT   |         |
| W.L.        | AUTO    | W.L.    | AUTO    |
| REAR        | MANU    | REAR    | MANU    |
| [ IN ]      | [ LVL ] | [ IN ]  | [ LVL ] |

When using a two channel wireless receiver, select [DUAL] in the [WIRELESS TYPE] item on the setting menu [AUDIO SETUP] screen.

### Using audio devices

**1** Connect the audio device to the <AUDIO IN> terminal of the camera with the XLR cable.

**2** According to the channel to which the XLR cable is connected, switch the input signal to [REAR] on the [AUD02:INPUT] screen of SmartUI.

**3** Set the <LINE>/<MIC> selector switch on the rear panel to <LINE>.

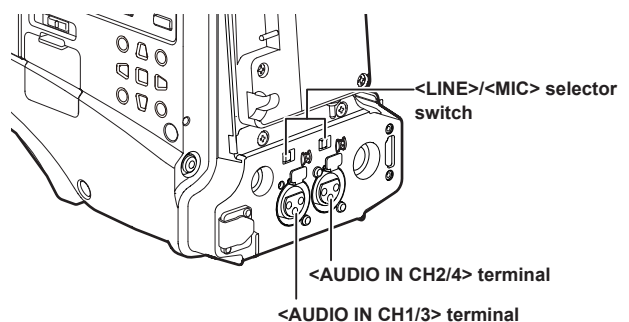



## Mounting accessories

### Mounting the camera on a tripod

When mounting the camera on a tripod, use the optional tripod adaptor (SHAN-TM700).

#### 1 Mount the tripod adaptor on the tripod.

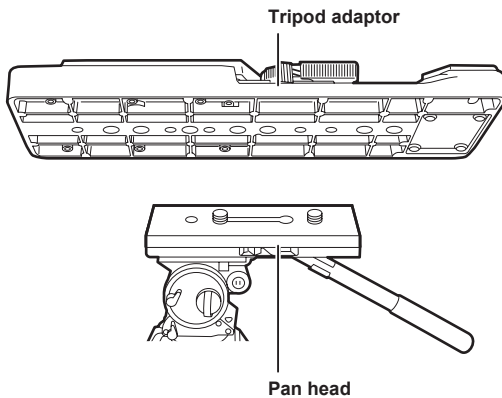

#### 2 Mount the camera on the tripod adaptor.

Slide the camera forward along the grooves until you hear a click.

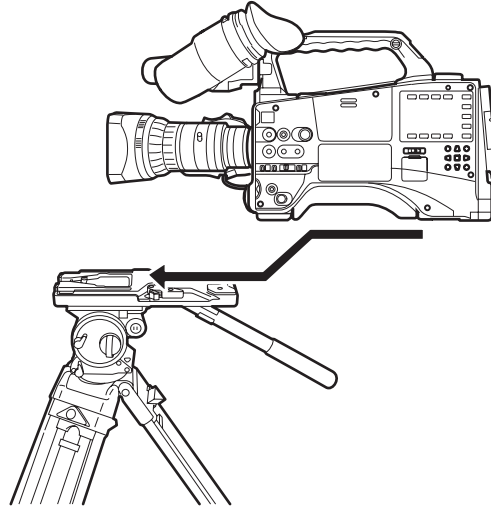

#### NOTE

- Select an appropriate hole in the adaptor, taking into account the center of gravity of the camera and tripod adaptor combined. Also, make sure that the diameter of the selected hole matches the diameter of the pan head screw.

### Removing the camera from the tripod adaptor

While holding the red lever down, move the black lever in the direction of the arrow, and slide the camera backward to remove it.

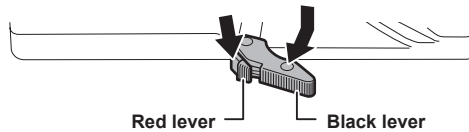

#### NOTE

- If the tripod adaptor pin does not return to its original position after the camera has been removed, hold the red lever down and move the black lever in the direction of the arrow again, in order to return the pin to its original position. Note that the camera cannot be mounted if the pin remains in the center.

### Attaching the shoulder strap

Attach the shoulder strap to the shoulder strap fittings.

To detach the shoulder strap, first open the hooks, then detach the strap.

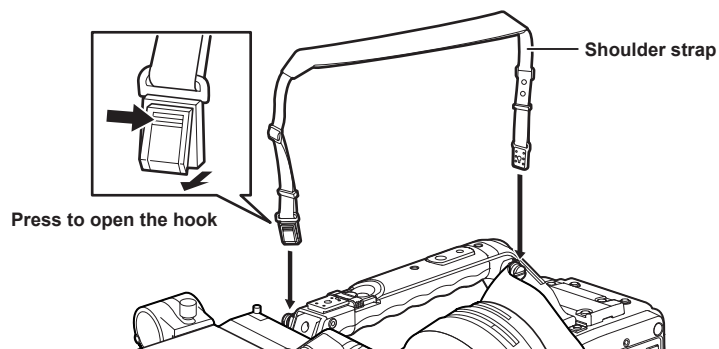

#### NOTE

- Make sure that the shoulder strap is securely attached.

**Attaching the rain cover**

Using the SHAN-RC700 rain cover

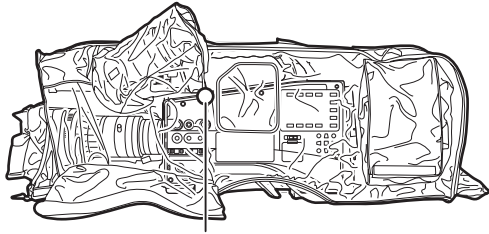

**Tighten the cord**

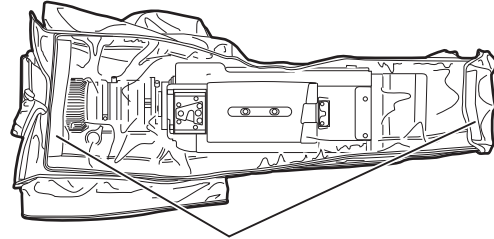

**Secure with the surface fastener**

## Connecting the <DC OUT> terminal with the external recording start/stop switch

It is possible to retrieve 1.5 A current from the <DC OUT> terminal of the camera.

Recording start/stop can be controlled by connecting an external switch to this terminal.

Since a tally lamp can be used by connecting an LED to this terminal, it is useful for shooting video when fixing the camera on a crane.

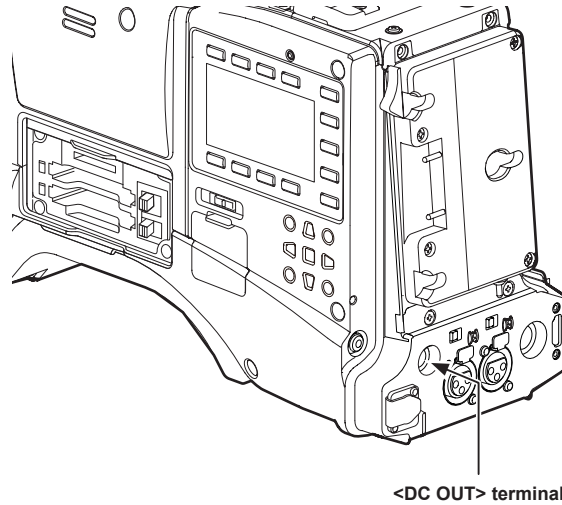

(Connection example)

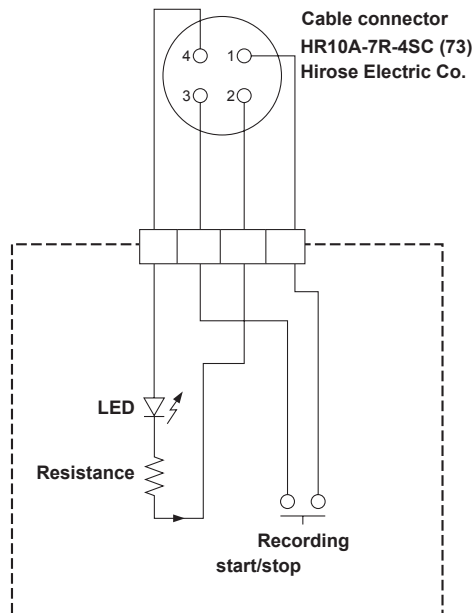

1 GND

2 TALLY OUT

Open collector output on the camera side

|                |                |
|----------------|----------------|
| Tally lamp on  | Low impedance  |
| Tally lamp off | High impedance |

3 Recording start/stop switch

This is connected in parallel to the <REC> button on the camera or the VTR button on the lens.

4 +12 V

### NOTE

- Make sure that polarity is correct before connecting an external device. Failure to do so may result in a malfunction.

## Chapter 6 **Thumbnail Operations for Clips**

---

The images and voices created from one shooting session, together with additional information such as text memos and metadata are saved as clips. You can play back and edit clips with the camera.

# Thumbnail operations

## Thumbnail operation overview

A clip is a data group that includes the images and voices created from one shooting session, together with additional information such as text memos and metadata.

The following operations can be performed using the cursor and <SET> button while checking the thumbnails of clips displayed on the viewfinder screen.

- Play back, delete, copy, or restore clips.
- Add or delete a shot mark and text memo on the clip thumbnail.
- Copy part of a clip using the text memo.
- Change the thumbnail image using the text memo.
- Format P2 cards and SD memory cards.
- Upload and edit clip metadata from the SD memory card.

Thumbnail screens are configured as follows.

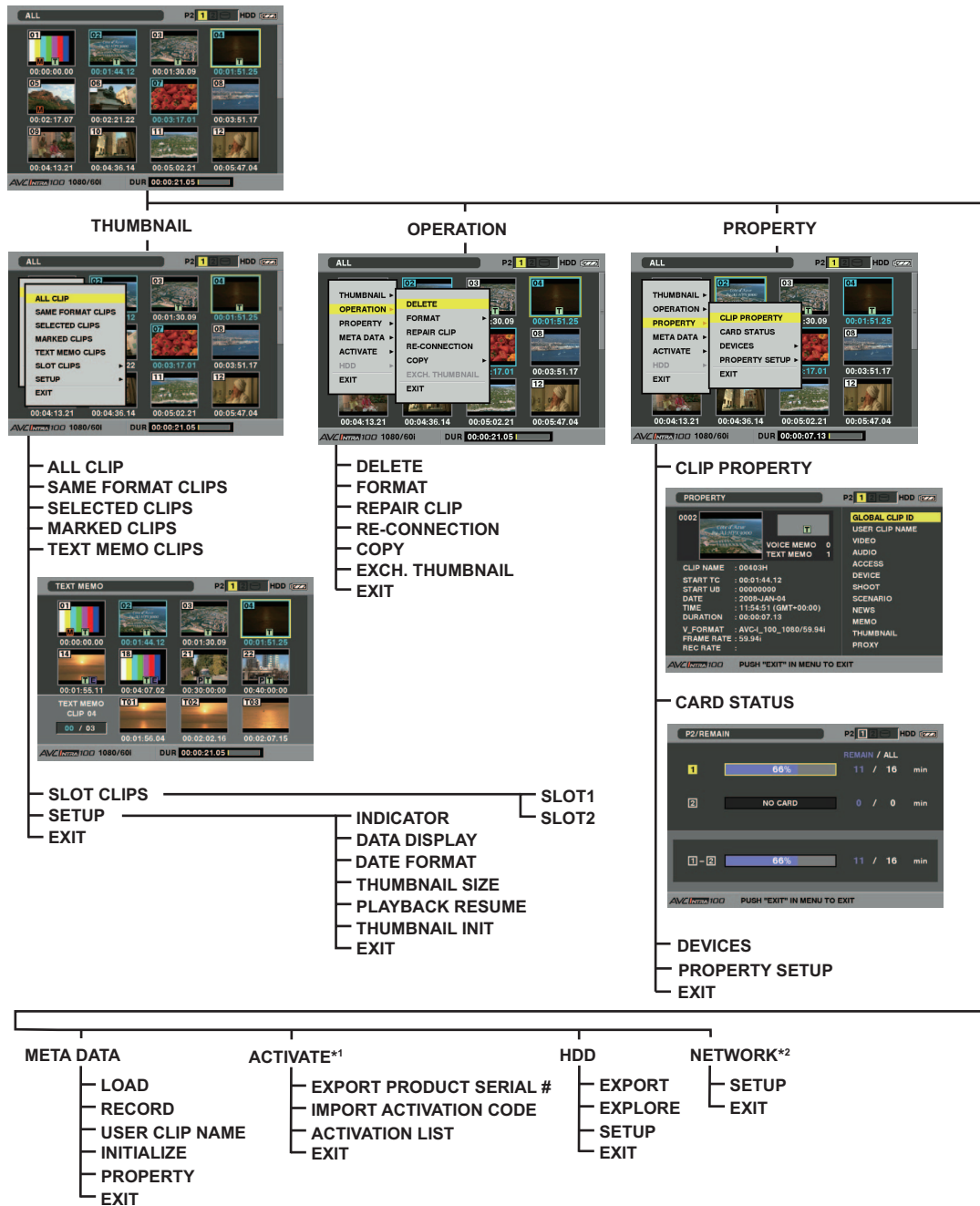

\*1 This is a menu to enable the optional functions (extra-cost options). For details, refer to the operating instructions for each option.

\*2 The [NETWORK] can be selected when the necessary Upgrade Software Key is installed.

**Thumbnail screen**

Press the <THUMBNAIL> button to display the thumbnail screen on the viewfinder screen. Press the <THUMBNAIL> button again to return to the regular display. Also, when changing from the regular display to the thumbnail screen display, all clips will be displayed on the thumbnail screen. Also, press the <THUMBNAIL MENU> button from the thumbnail screen to enable thumbnail menu operations.

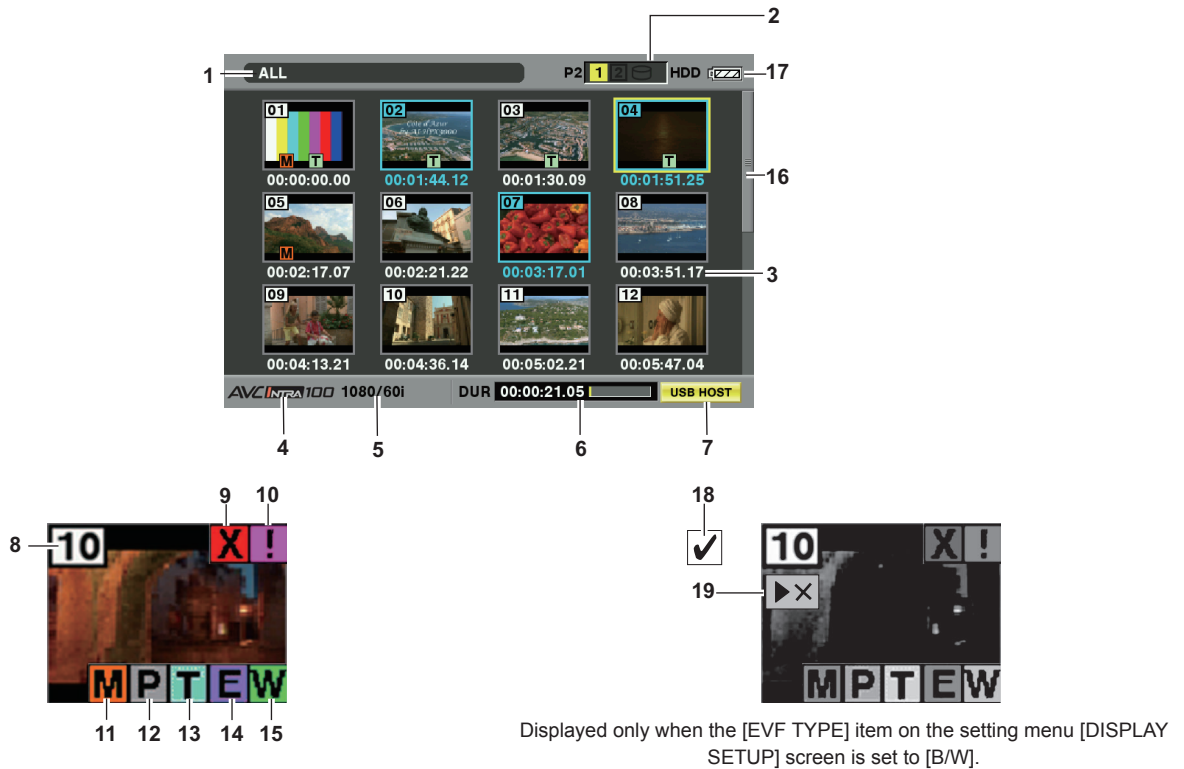

Displayed only when the [EVF TYPE] item on the setting menu [DISPLAY SETUP] screen is set to [B/W].

**1 Display mode**

Displays the type of the thumbnail displayed on the screen, and the types of the other information screens.

|               |   |
|---------------|---|
| [ALL]         | Displays all clips.   |
| [SAME FORMAT] | Displays clips in the same format as the system format [SYSTEM MODE] item, and [REC FORMAT] item. For details on each item, refer to “Selecting recording signals” (page 48).   |
| [SELECT]      | Displays clips selected with the <SET> button.  |
| [MARKER]      | Displays clips with shot marks.   |
| [TEXT MEMO]   | Displays clips with text memo data.   |
| [SLOT n]      | Displays clips in the specified P2 card. (n: indicates slot number 1 to 2.)   |
| [UPDATING..]  | Displayed during processing such as screen update. Also during updating the rotating icon [ ] is displayed. For details, refer to “Switching the thumbnail display” (page 104). |

**2 Slot number, hard disk drive status**

Indicates on which P2 card the pointed clip is recorded. The slot number of the P2 card that contains clips is indicated in yellow. If the clips are recorded on multiple P2 cards, all slot numbers of the P2 cards that contain the clips are indicated in yellow. The slot numbers are indicated in white if they contain P2 cards.

When the following P2 card is inserted, the slot number is displayed with a pink frame.

- [RUN DOWN CARD] (A P2 card on which the maximum number of overwrites has been exceeded.)
- [DIR ENTRY NG CARD] (A P2 card in which the directory structure is not supported.)

The USB hard disk drive is indicated as follows.

|  |        |
|--|--------|
| Other than the USB host mode                                     | Gray   |
| Not connected in USB host mode                                   | Gray   |
| Hard disk drive recognized and usable in USB host mode           | White  |
| Hard disk drive recognized and thumbnails shown in USB host mode | Yellow |
| Hard disk drive recognized and not usable in USB host mode       | Red    |

**3 Time display**

Displays any one of the time code [TC] at the start of clip recording/user bits [UB] at the start of clip recording/shooting time [TIME]/shooting date [DATE]/shooting date and time [DATE TIME]/clip name [CLIP NAME]/user clip name [USER CLIP NAME] according to the setting.

**4 Recording mode**

Displays the recording mode for the clip on which the pointer is located.

**5 System format**

Displays the format for the clip on which the pointer is located.

**6 Duration/meter display**

Displays the duration of the clip on which the pointer is located. The meter display indicates the playback position in the clip.

**7 USB host/WLAN/LAN indicator**

The USB host indicator is displayed in USB host mode; the WLAN indicator is displayed in WLAN mode; the LAN indicator is displayed in LAN mode.

**8 Clip number**

The numbers set by the camera for all the clips recognized correctly by the P2 card. These numbers are allocated in chronological order by shooting date and time.

If clips cannot be played because of different recording formats, they are displayed in red.

**9 [X] Defective clip indicator/[?] Unknown clip indicator**

Displayed for defective clips, which may result from various causes such as turning off the power during recording.

Clips with yellow defective clip indicators can sometimes be restored.

For details, refer to “Restoring clips” (page 107).

Clips with red defective clip indicators cannot be restored and must be deleted. If the clip cannot be deleted, format the P2 card.

[?] is displayed for clips which differ in format from the P2 standard.

**10 [I] Incomplete clip indicator**

Displayed when clips are recorded on multiple P2 cards and either of the P2 cards is not inserted in a P2 card slot.

**11 [M] Shot mark indicator**

Displayed for the clip of a thumbnail with a shot mark attached.

For details, refer to “Shot mark recording function” (page 44).

**12 [P] Indicator for clips with proxy**

Displayed for clips with proxy attached.

**13 [T] Text memo indicator**

Displayed for clips with text memo data attached.

**14 [E] Edit copied clip indicator**

Displayed on an edit copied clip when the model supports edit copy, such as the AJ-HPM200. For more information about edit copying, refer to the operating instructions for a model that supports edit copying.

**15 [W] Wide clip indicator**

Displayed for clips recorded with the 16:9 aspect ratio. However, it does not accompany clips in HD format.

**16 Thumbnail scroll bar**

Indicates which part of the whole thumbnail is currently being viewed.

**17 Remaining battery charge display**

Displays remaining battery level. For details, refer to “Battery charge level display” (page 74) on the “Viewfinder status display” section.

**18 [✓] Selected clip indicator**

Displays the selection status of the clip when a clip is selected.

**19 [X] Not playable clip indicator**

Displayed when clips cannot be played back.

**NOTE**

- The [✓] selected clip indicator and the [X] not playable clip indicator are displayed only when the [EVF TYPE] item on the setting menu [DISPLAY SETUP] screen is set to [B/W].

**Selecting thumbnails**

Multiple thumbnails can be randomly selected on the thumbnail screen.

**1 Use the cursor buttons to move the pointer (yellow frame) to the desired clip and press the <SET> button.**

The frame around the selected thumbnail changes to a blue frame.

Press the <SET> button again to deselect the clip.

The blue frame display and the selected clip indicator are displayed when [B/W] is selected with the [EVF TYPE] item on the setting menu [DISPLAY SETUP] screen.

**2 To select additional clips, repeat step 1.**

It is possible to display only the selected thumbnails on the thumbnail screen for playback.

For details, refer to “Switching the thumbnail display” (page 104).

**NOTE**

- While holding down the <SHIFT> button, use the cursor up and down buttons (Δ/▽) to move the pointer to the first or last clips.
- After selecting a clip, move the pointer to another clip and while holding down the <SHIFT> button, press the <SET> button to select all clips from the previously selected clip to the pointer position.
- While holding down the <SHIFT> button, press the <EXIT> button to deselect all the clips.

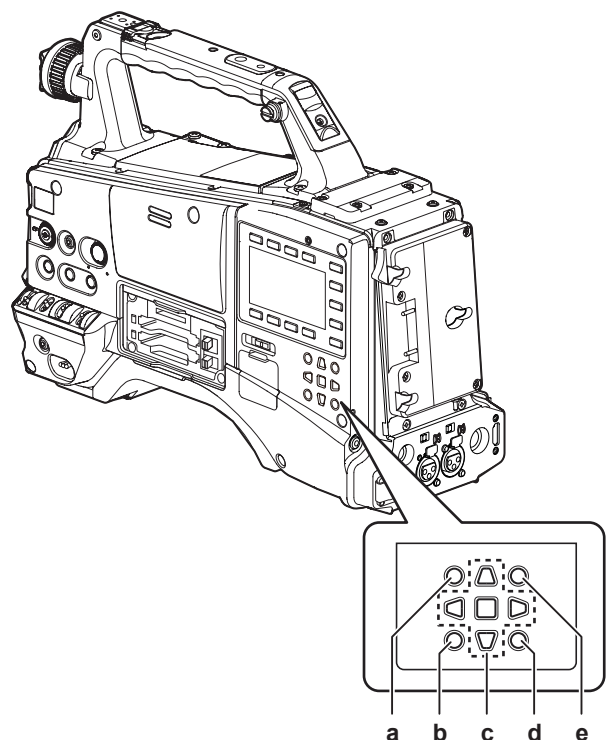

- a: <THUMBNAIL> button
- b: <EXIT> button
- c: ▲▶▼◀ cursor buttons  
■<SET> button

- d: <THUMBNAIL MENU> button
- e: <SHIFT> button

**Playing back clips**

- 1 Press the <THUMBNAIL> button.**  
The thumbnail screen appears on the viewfinder screen.
- 2 Use the cursor buttons to move the pointer over the desired clip.**
- 3 Press the <PLAY/PAUSE> button.**
  - The clip under the pointer will be played back on the viewfinder screen.
  - After playback of the clip under the pointer has ended, subsequent clips are played back in order on the thumbnail screen, and when playback of the last clip ends, view returns to the thumbnail screen.

**NOTE**

- When playing back clips it is not necessary to select the clips (blue frames around the thumbnails).
- Clips with clip numbers displayed in red\* cannot be played.
- \* The not playable clip indicator is displayed when [B/W] is selected with the [EVF TYPE] item on the setting menu [DISPLAY SETUP] screen.

- During playback of clips, press the <◀◀/REW> button to start 4x speed reverse playback, and the <▶▶/FF> button to start 4x speed fast playback. Press the <PLAY/PAUSE> button to return to normal playback.
- During playback of clips, press the <PLAY/PAUSE> button to pause the playback.  
During a pause, press the <◀◀/REW> button to pause the playback at the beginning of the clip. Press the <◀◀/REW> button again to pause the playback at the beginning of the previous clip.  
During a pause, press the <▶▶/FF> button to pause the playback at the beginning of the next clip.
- Pressing the <STOP> button during clip playback stops the playback and returns the display to the thumbnail screen.

**NOTE**

- When playback is stopped, the position of the pointer moves to the clip that was being played back, regardless of where the playback started.
- Press the <PLAY/PAUSE> button again to start playback from the beginning of the clip under the pointer. To continue to play back from where previously stopped, turn the [PLAYBACK RESUME] setting in "Setting the thumbnail display" (page 111) to [ON].

**Switching the thumbnail display**

The display can be switched so that only those clips matching the specified conditions are displayed on the thumbnail screen.

- 1 Press the <THUMBNAIL> button.**  
The thumbnail screen appears on the viewfinder screen.
- 2 Press the <THUMBNAIL MENU> button.**  
The thumbnail menu appears.

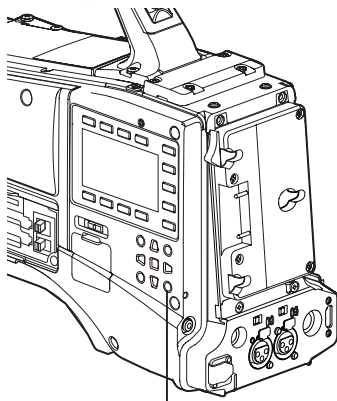

<THUMBNAIL MENU> button

- 3 Select [THUMBNAIL] from the thumbnail menu.**  
Switch the thumbnail display by selecting one of the items.



|                     |  |
|---------------------|--|
| [ALL CLIP]          | Displays all clips.  |
| [SAME FORMAT CLIPS] | Displays clips of the current system format.   |
| [SELECTED CLIPS]    | Displays randomly selected clips. The thumbnails appear in selected order.   |
| [MARKED CLIPS]      | Displays clips with shot marks attached.   |
| [TEXT MEMO CLIPS]   | Displays clips with text memo data.  |
| [SLOT CLIPS]        | Displays clips recorded in the P2 card inserted in the specified slot.<br>When [SLOT CLIPS] is selected, [SLOT1] to [SLOT2] are displayed as a sub-menu, select the desired slot to display the clips. |
| [SETUP]             | Refer to "Setting the thumbnail display" (page 111) for information about this item.   |
| [EXIT]              | Closes the sub-menu.   |

**Changing thumbnails**

Replace thumbnails with images that include previously attached text memos while images are recorded or played back.

- 1 Add text memos to images to be changed.**  
For details on adding text memos, refer to "Text memo recording function" (page 45).
- 2 Select the thumbnail menu → [THUMBNAIL] → [TEXT MEMO CLIPS] to display thumbnails of the clips with text memos.**
- 3 Place the pointer on the clip of the thumbnail to be changed and press the <SET> button, and then move the pointer to the text memo display on the lower row.**



- 4 Select the thumbnail to be replaced from text memos, place the pointer on it, and select [OPERATION] → [EXCH. THUMBNAIL] on the thumbnail menu.

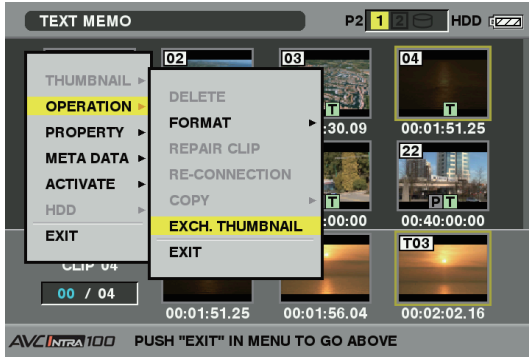

- 5 Press the <SET> button to display the [YES]/[NO] confirmation screen, and use the cursor buttons and the <SET> button to select [YES].

The menu closes and the thumbnail for the clip is replaced.

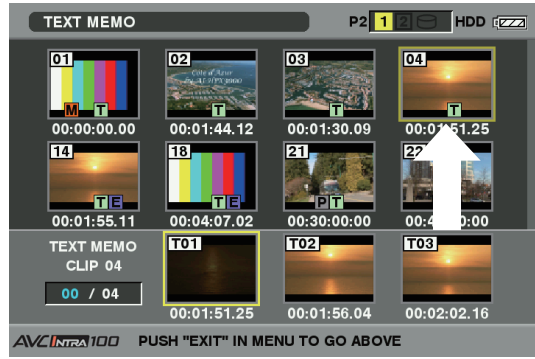

**NOTE**

- Display clip properties by selecting the thumbnail menu → [PROPERTY] → [CLIP PROPERTY] to confirm the position of the thumbnail in the [THUMBNAIL] item (the number of frames from the top of the clip). Since thumbnails usually come from the top of the clip, 0 is displayed.

**Shot mark**

Shot marks can be added to a clip thumbnail to distinguish the clip from others.

- 1 Press the <THUMBNAIL> button.  
The thumbnail screen appears on the viewfinder screen.
- 2 Use the cursor buttons to move the pointer over the clip to which you want to attach a shot mark.
- 3 Press the <USER> buttons to which the shot mark recording function is assigned or the <RET> button on the lens.  
  - This adds a shot mark to the thumbnail of the clip at the pointer position.

- To delete a shot mark, place the pointer again and press the <USER> buttons to which the shot mark recording function is assigned or the <RET> button on the lens.

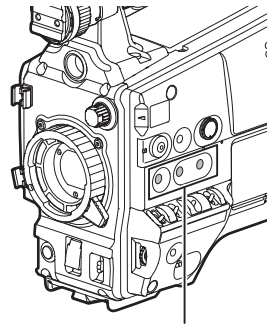

<USER MAIN>/<USER1>/<USER2> buttons

**NOTE**

- A shot mark can be attached during recording.
- Add shot marks after recording stops to attach the shot mark to the most recently recorded clip.  
For details, refer to "Shot mark recording function" (page 44).
- When adding a shot mark to or deleting the shot mark from a clip recorded across multiple P2 cards, do this with all these P2 cards inserted into card slots.

**Text memo**

During recording or playback, you can add text memos. Text memos can be used to play back clips at some point or break clips into chunks and copy the necessary portions.

**Adding a text memo**

Text memos can be added in one of the following ways.

- Press the <USER> buttons to which the text memo recording function is assigned or the <RET> button on the lens during recording/playback.  
This adds a text memo at the position where the button was pressed.
- While the thumbnail screen is displayed, press the <USER> buttons to which the text memo recording function is assigned or the <RET> button on the lens to add a text memo at the beginning of a clip.

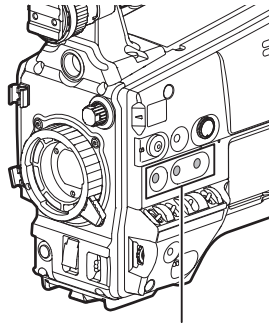

<USER MAIN>/<USER1>/<USER2> buttons

**NOTE**

- Up to 100 text memos including voice memos can be recorded to a clip. However, voice memos cannot be recorded/played back on the camera.

**Playing back from the text memo position**

**1 Press the <THUMBNAIL> button.**

The thumbnail screen appears on the viewfinder screen.

**2 Press the <THUMBNAIL MENU> button and select [THUMBNAIL] → [TEXT MEMO CLIPS] from the thumbnail menu.**

The clip thumbnails with text memos attached are displayed in the upper section of the viewfinder screen. The lower section of the viewfinder screen shows information about the text memo on the clip selected by the pointer.

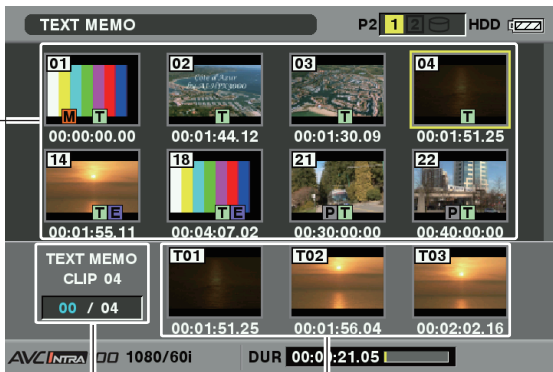

Thumbnail display

Display still image linked to text memo

Selected number (blue) and total number (white) of text memo clips

**3 Move the pointer over the clip that contains the desired text memo to play back and press the <SET> button.**

The pointer moves to the lower part of the viewfinder screen.



The pointer moves down.

**4 With the pointer located in the lower part, move the pointer to the desired text memo number using the cursor right and left buttons (<◀/▶>), then press the <PLAY/PAUSE> button.**

- Playback will start from the time code position of the text memo where the pointer is located.
- If the <STOP> button is pressed during playback or the playback has finished at the end of the clip, then the thumbnail screen appears again with the pointer placed on the thumbnail of the text memo where the playback started.
- While holding down the <SHIFT> button, use the cursor up and down buttons (<▲/▼>) to move the pointer to the first or last text memo.
- Press the <THUMBNAIL MENU> button and select [EXIT] or press the <EXIT> button to return the pointer to the upper part of the thumbnail screen.

**NOTE**

- Pressing the <REC> button while the text memo screen is being displayed will not start recording.
- For AVC-Intra format clips that cannot be played back, text memo thumbnails are not displayed and may be shown as the thumbnail image with the [ ] mark.

**Deleting text memos**

**1 Perform steps 1 to 3 in “Playing back from the text memo position” (page 106) to select the desired text memo in a clip.**

**2 Move the pointer to the text memo to be deleted and press the <SET> button.**

**3 Press the <THUMBNAIL MENU> button, and select [OPERATION] → [DELETE] from the menu.**

When [YES] and [NO] appear to confirm deletion, select [YES] using the cursor buttons and the <SET> button to delete the text memo.

## Using a text memo to divide a clip and copy the necessary portion

- 1 Perform steps 1 to 3 in “Playing back from the text memo position” (page 106) to select the desired text memo in a clip.
- 2 Move the pointer to the text memo to be copied and press the <SET> button.  
You can select multiple text memos.
- 3 Press the <THUMBNAIL MENU> button, and select [OPERATION] → [COPY].
- 4 Use the cursor buttons and the <SET> button to select the destination slot, and then select [YES].
  - Copying starts.

- The portion between the selected text memo and the next one is copied. If no text memo is found after the selected one, then the part after the selected text memo to the end of the clip is copied.
- If multiple text memos are selected, the selected sections are copied.
- While the clip is being copied, the camera indicates the progress of the copy process and cancelation status. To discontinue the copy process, press the <SET> button. When the [YES]/[NO] confirmation screen is displayed, use the cursor buttons and the <SET> button to select [YES].

 NOTE

- In clip division and copying using the text memo function, the area copied may be automatically modified depending on the recording format of the clip.

## Deleting clips

- 1 Press the <THUMBNAIL> button.  
The thumbnail screen appears on the viewfinder screen.
- 2 Use the cursor buttons to move the pointer over the clip to be delete and press the <SET> button to select the clip.
- 3 Press the <THUMBNAIL MENU> button, and select [OPERATION] → [DELETE] from the thumbnail menu.

- 4 When the following screen appears, use the cursor buttons and the <SET> button to select [YES].

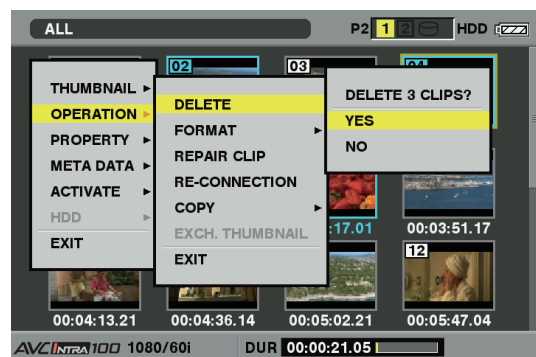

The clip is deleted. All selected clips (in blue-green frames) are deleted by this operation.

 NOTE

- To interrupt deleting, press the <SHIFT> button + <EXIT> button or the <SET> button to cancel the operation. The already deleted clips cannot be restored even if the deletion process is aborted.

## Restoring clips

Restores clips that are defective as a result of sudden power-down during recording or removal of the P2 card being accessed.

 NOTE

- The clips with yellow defective clip indicators can be restored. Delete clips with red defective clip indicators. If the clips cannot be deleted, format the P2 card.  
During restoration of the clips, however, the defective clip indicator may change from yellow to red, and result in inability to restore the clips.

- 1 Press the <THUMBNAIL> button.  
The thumbnail screen appears on the viewfinder screen.
- 2 Use the cursor buttons to move the pointer over the clip to be restored (defective clips are indicated by defective clip marks) and press the <SET> button to select the clip.

- 3 Press the <THUMBNAIL MENU> button, and select [OPERATION] → [REPAIR CLIP] from the thumbnail menu.  
When a confirmation screen asks you to confirm that you want to repair the clip, select [YES] using the cursor buttons and the <SET> button to restore the clip.

## Reconnecting incomplete clips

Incomplete clips may be generated when clips recorded on multiple P2 cards (connected clips) are separately copied from each card. The reconnection function generates one clip (the original, connected clip) from incomplete clips.

- 1 Press the <THUMBNAIL> button.  
The thumbnail screen appears on the viewfinder screen.
- 2 Use the cursor buttons and the <SET> button to select incomplete clips to be reconnected.  
Usually, thumbnails of incomplete clips (clips with  indicator) are displayed in line.

- 3 Press the <THUMBNAIL MENU> button, and select [OPERATION] → [RE-CONNECTION] from the thumbnail menu.  
When a confirmation screen asks you to confirm that you want to reconnect the clip, select [YES] using the cursor buttons and the <SET> button to reconnect the incomplete clips.

**NOTE**

- Incomplete clip indicators will remain displayed when only some clips are reconnected, unless all the constituent clips of the original clip are reconnected.

**Copying clips**

Selected clips can be copied to the P2 card or SD memory card in the desired slot.

**1 Press the <THUMBNAIL> button.**

The thumbnail screen appears on the viewfinder screen.

**2 Use the cursor buttons to move the pointer to the clip to be copied, and press the <SET> button to select the clip.**

**NOTE**

- If recording using the one-clip recording function in which the clip can be recorded connected to the previous clip (when [1\*CLIP] is displayed), then copying of clips is not possible. Close the menu and press the <STOP> button for approximately two seconds to stop combining to the clip, and try the operations again.

**3 Press the <THUMBNAIL MENU> button, and select [OPERATION] → [COPY] from the thumbnail menu.**

- Select slot 1, 2, or SD memory card as the copy destination.

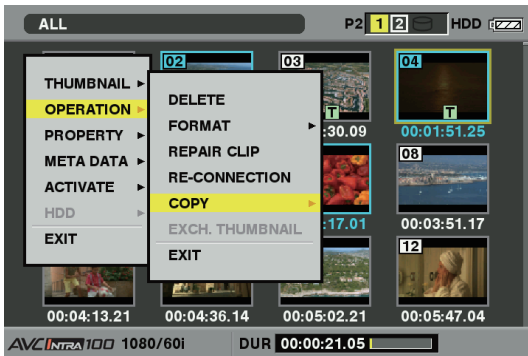

- When a confirmation screen asks you to confirm that you want to copy the clip, select [YES] using the cursor buttons and the <SET> button to copy the clip.

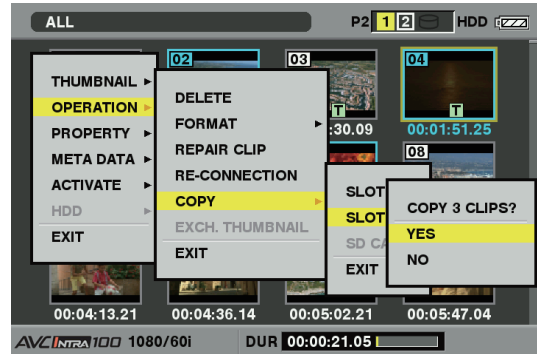

**NOTE**

- Do not turn off the power or remove a P2 card while data is being copied because doing so may cause the card to fail. If defective clips are generated by accidentally performing one of the above operations, delete them, and then copy them again.
  - When clips are copied to P2 cards, all the information on the clips is copied, however, when they are copied to an SD memory card\*, video and sound information is not copied, only thumbnails, clip metadata, icons, Voice Memo, proxy and real-time metadata.
  - When recording capacity on the copy destination is insufficient, [LACK OF CAPACITY!] is displayed and copying is not performed. When clips to be copied include defective clips, [CANNOT ACCESS!] is displayed and copying is not performed. When selected clips include a clip that has been recorded on the same card as the destination P2 card, copying is not performed.
  - To interrupt copying, press <SHIFT> button + <EXIT> button or the <SET> button to cancel the operation. The clip being copied will be deleted from the copy destination.
  - When identical clips exist on the destination card, the message [OVERWRITE?] is displayed. Select [YES] to proceed with overwrite, or [NO] to not proceed.
- \* For details on SD memory cards to be used, refer to "Cautions in using SD memory cards" (page 25).

**Setting clip metadata**

Information such as the name of the person who shot the video, the name of the reporter, the shooting location, or a text memo can be read from the SD memory card, and can be recorded as clip metadata.

**Reading clip metadata (metadata upload)**

**1 Insert the SD memory card that contains the clip metadata (metadata upload file).**

**2 Press the <THUMBNAIL> button.**

The thumbnail screen appears on the viewfinder screen.

**NOTE**

- With the thumbnail screen displayed, press the <THUMBNAIL MENU> button while pushing the <DISP/MODE CHK> switch towards the <CHK> side to move to step 4.

**3 Press the <THUMBNAIL MENU> button, select [META DATA] → [LOAD] from the thumbnail menu, and then press the <SET> button.**

The metadata name of the metadata upload file on the SD memory card is displayed.



**4 Use the cursor buttons to select the desired file to be read, and select [YES].**

- Upload starts.
- Uploaded data is retained even if the power is turned off.
- For details on confirmation of uploaded data, refer to “Checking and modifying uploaded metadata” (page 109).

**NOTE**

- During display of metadata names, press the cursor button (▷) to switch to display of file names. Press the cursor button (◁) to return to display of metadata names.

**Clip metadata items**

Clip metadata includes the following items. Underlined items can be set by reading the metadata upload file on the SD memory card. Other items are set automatically during shooting. Using the latest update version of P2 Viewer Plus, metadata upload files can be written to SD memory cards using a computer. Download and install the latest version of P2 Viewer Plus from the following URL.

<http://pro-av.panasonic.net/>

For details on SD memory cards to be used, refer to “Cautions in using SD memory cards” (page 25).

**NOTE**

- Files which were not edited by P2 Viewer Plus are displayed as [UNKNOWN DATA!] and may not be readable.

|                  |   |
|------------------|---|
| [GLOBAL CLIP ID] | Displays the global clip ID that shows the shooting status of the clip.   |
| [USER CLIP NAME] | Displays the clip name set by the user.*1   |
| [VIDEO]          | Displays [FRAME RATE] (frame rate) (frame rate of the clip), [PULL DOWN] (pull-down) (pull-down format), and [ASPECT RATIO] (aspect ratio).   |
| [AUDIO]          | Displays [SAMPLING RATE] (sampling frequency of recorded audio) and [BITS PER SAMPLE] (quantizing bits for recorded audio).   |
| [ACCESS]         | Displays [CREATOR] (person who recorded the clip), [CREATION DATE] (date when the clip was recorded), [LAST UPDATE DATE] (date of the latest update of the clip), and [LAST UPDATE PERSON] (person who made the latest update of the clip).   |
| [DEVICE]         | Displays [MANUFACTURER] (name of the device manufacturer), [SERIAL NO.] (serial number of the device), and [MODEL NAME] (model name of the device).   |
| [SHOOT]          | Displays [SHOOTER] (name of the person who shot the video), [START DATE] (start date of shooting), [END DATE] (end date of shooting), and [LOCATION]/[ALTITUDE]/[LONGITUDE]/[LATITUDE]/[SOURCE]/[PLACE NAME] (altitude, longitude, latitude, and source of the information and name of the location). |
| [SCENARIO]       | Displays [PROGRAM NAME], [SCENE NO.], and [TAKE NO.].   |
| [NEWS]           | Displays [REPORTER] (name of the reporter), [PURPOSE] (purpose of shooting), and [OBJECT] (object of shooting).   |
| [MEMO]*2         | Displays [NO.] (the number of the text memo), [OFFSET] (location of the frame where the text memo is added), [PERSON] (person who recorded the text memo added to the clip), and [TEXT] (content of the text memo).   |
| [THUMBNAIL]      | Displays the location of the frame (frame offset) and the size (height and width) of the image selected as the thumbnail image.   |
| [PROXY]          | Displays information such as proxy format when proxy is added.  |

\*1 The [USER CLIP NAME] recording method is selectable. For details, refer to “Selecting the [USER CLIP NAME] recording method” (page 110).

\*2 When entering [MEMO], make sure to enter [TEXT]. It is not possible to record only [PERSON] (the person inputting the memo), or [OFFSET] (the recording position).

**Checking and modifying uploaded metadata**

Details of metadata uploaded from an SD memory card can be checked.

**1 Press the <THUMBNAIL> button.**

The thumbnail screen appears on the viewfinder screen.

**2 Press the <THUMBNAIL MENU> button, and select [META DATA] → [PROPERTY] from the thumbnail menu.**

The following screen is displayed.

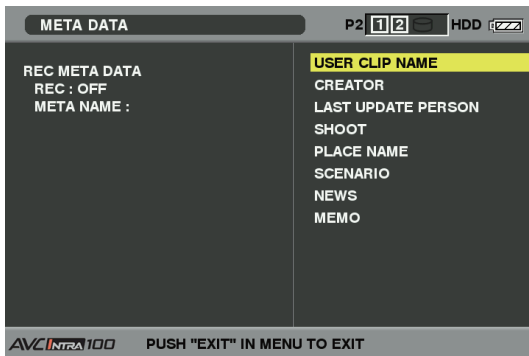

**3 Use the cursor buttons to move the pointer to the item to be checked, and press the <SET> button.**

Settings of the uploaded metadata can be checked.

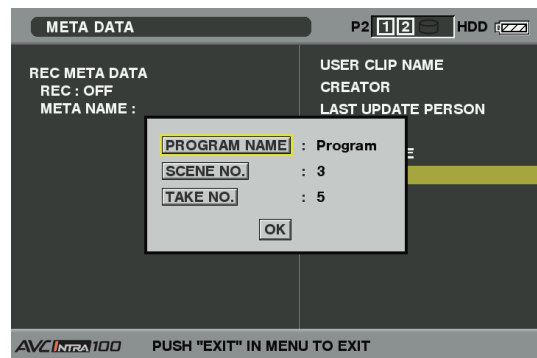

**4 While checking the settings for the metadata, use the cursor buttons to move the pointer to the item to be changed, and press the <SET> button.**

- A software keyboard screen is displayed, allowing you to modify the setting.

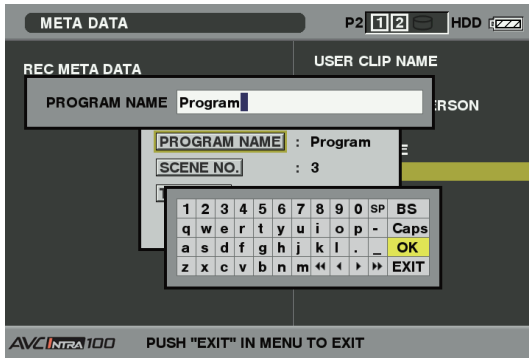

- While holding down the <SHIFT> button, press the cursor up or down button (△/▽) to move to the start or end of the content to change.

### Setting whether to record the uploaded metadata

From the thumbnail menu, select [META DATA] → [RECORD] item, and set it to [ON]/[OFF]. This item is set to [OFF] in the factory settings.

### Selecting the [USER CLIP NAME] recording method

From the thumbnail menu, select [META DATA] → [USER CLIP NAME], and select the recording method of [USER CLIP NAME] from either [TYPE1] or [TYPE2].

#### ■ [TYPE1] (factory setting)

| Status of clip metadata   | [USER CLIP NAME] to be recorded      |
|---|--------------------------------------|
| When clip metadata has been loaded  | Uploaded data                        |
| When no clip metadata has been loaded, or when setting disables recording of loaded clip metadata | Same as [GLOBAL CLIP ID] (UMID data) |

#### ■ [TYPE2]

| Status of clip metadata   | [USER CLIP NAME] to be recorded |
|---|---------------------------------|
| When clip metadata has been loaded  | Uploaded data + [COUNT] value*  |
| When no clip metadata has been loaded, or when setting disables recording of loaded clip metadata | Same as [CLIP NAME]             |

\* The [COUNT] value is indicated as a four digit number.

The [COUNT] value is incremented each time a new clip is captured if clip metadata has been read in and [TYPE2] has been selected as the recording method. The [COUNT] value can be reset using the following method.

Select [META DATA] → [PROPERTY] from the thumbnail menu, and select the [USER CLIP NAME] item to display the following screen. Move the cursor over [COUNT RESET], and press the <SET> button to reset the [COUNT] value to 1.

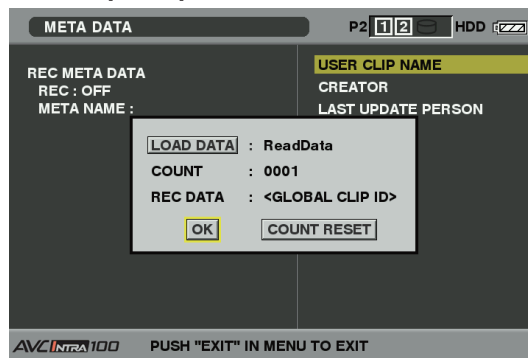

### NOTE

- When a P2 card with a memory capacity of 8 GB or more is used in the camera, and a one-time continuous recording exceeds the prescribed duration (DVCPRO HD and AVC-Intra 100: approximately five minutes; DVCPRO50 and AVC-Intra 50: approximately ten minutes; DVCPRO or for DV: approximately 20 minutes), or when a one-time recording extends over more than one P2 card, the recording concerned will automatically be recorded as a separate clip. At this time, each clip will be provided with its own [COUNT] value.

#### ■ Example of recording ([DVCPROHD]) a clip on a single P2 card

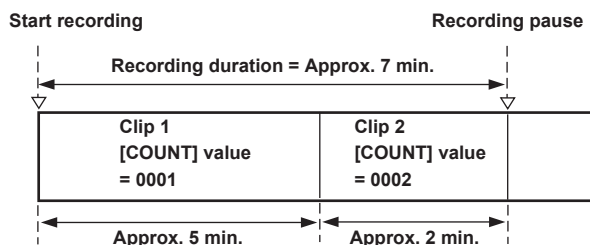

■ Example of recording a clip on two P2 cards

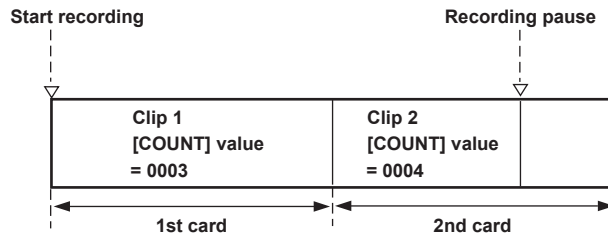

When the thumbnail and property of a clip recorded like the example above is displayed using a P2 device, the thumbnail and [COUNT] value of clip 1 will be displayed.

**Initializing the metadata setting**

Select [META DATA] → [INITIALIZE] from the thumbnail menu, and press the <SET> button. Select [YES] when the confirmation screen is displayed. The settings under [META DATA] in the thumbnail menu, including uploaded metadata, can be initialized.

**Formatting a P2 card**

**1 Press the <THUMBNAIL> button.**

The thumbnail screen appears on the viewfinder screen.

**2 Press the <THUMBNAIL MENU> button, and select [OPERATION] → [FORMAT] from the thumbnail menu.**

- When the following screen appears, select the slot number of the P2 card to be formatted and press the <SET> button.
- Select [EXIT] when you do not wish to format the card.

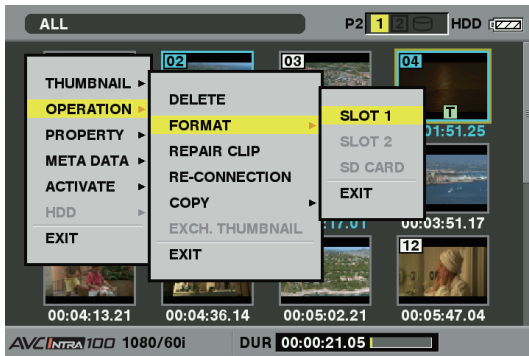

**3 When the following screen appears, select [YES] using the cursor buttons and the <SET> button.**

The selected P2 card is formatted.

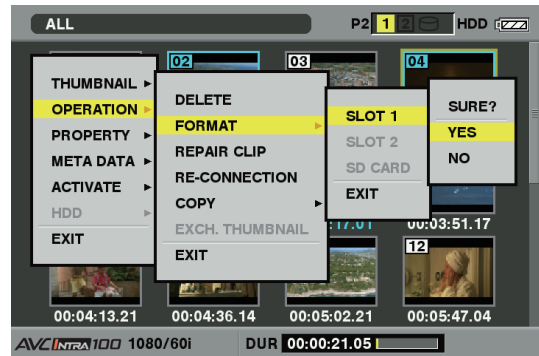

**NOTE**

- Since data that is deleted by formatting cannot be restored, be sure to check the data before executing formatting.

**Formatting SD memory cards**

SD memory cards can also be formatted from the thumbnail screen. With an SD memory card inserted into the camera, perform the following operation.

**1 Press the <THUMBNAIL> button.**

The thumbnail screen appears on the viewfinder screen.

**2 Press the <THUMBNAIL MENU> button, and select [OPERATION] → [FORMAT] from the thumbnail menu.**

- When the following screen appears, select [SD CARD] and press the <SET> button.
- Select [EXIT] when you do not wish to format the card.



**3 When the following screen appears, use the cursor buttons and the <SET> button to select [YES].**

The SD memory card is formatted.

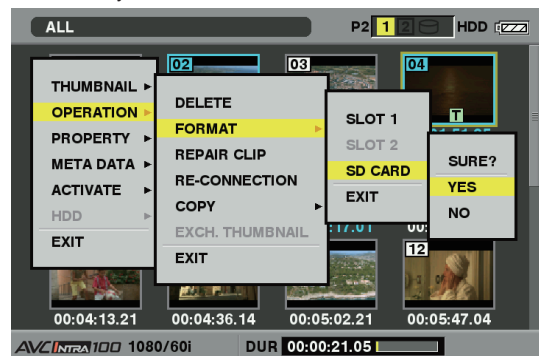

**NOTE**

- SD memory cards can also be formatted from the menu screen. For details, refer to "Formatting SD memory cards" (page 83).
- Since data that is deleted by formatting cannot be restored, be sure to check the data before executing formatting.

**Setting the thumbnail display**

The thumbnail display mode can be customized to suit your preferences.

**1** Press the <THUMBNAIL> button.

The thumbnail screen appears on the viewfinder screen.

**2** Press the <THUMBNAIL MENU> button, and select [THUMBNAIL] → [SETUP] from the thumbnail menu.

The following screen is displayed.

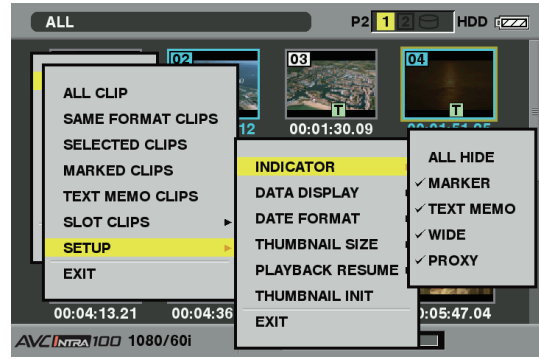

|  |  |   |  |
|--|--|---|--|
| [INDICATOR]  | Select which indicators you want to show on thumbnails and which you want to hide.   |   |  |
|  | [ALL HIDE]   | [ON]  | Hides all indicators, [MARKER], [TEXT MEMO], [WIDE], and [PROXY].                        |
|  |  | [OFF]   | According to the following menu, sets show or hide. This setting is the factory setting. |
|  | [MARKER]   | Switches the shot mark indicator between show and hide (on/off). The factory setting is on. |  |
|  | [TEXT MEMO]  | Switches the text memo indicator between show and hide (on/off). The factory setting is on. |  |
|  | [WIDE]   | Switches the wide indicator between show and hide (on/off). The factory setting is on.      |  |
| [PROXY]  | Switches the proxy indicator between show and hide (on/off). The factory setting is on.  |   |  |
| [DATA DISPLAY]   | Select the time display field of the clip from the time code [TC]/user bits [UB]/shooting time [TIME]/shooting date [DATE]/shooting date and time [DATE TIME]/clip name [CLIP NAME]/user clip name [USER CLIP NAME]. The factory setting is the time code.   |   |  |
| [DATE FORMAT]  | Select display order for recording date and time from Y-M-D (Year-Month-Day), M-D-Y (Month-Day-Year), or D-M-Y (Day-Month-Year). The factory setting may vary depending on the region. (AG-HPX610P: M-D-Y, AG-HPX610EJ: D-M-Y) This setting is reflected in the recording date and time shown in the clip property and the shooting date and time shown when [DATE] is selected under the item [DATA DISPLAY]. |   |  |
| [THUMBNAIL SIZE]   | Select the thumbnail displayed on the screen from either [LARGE] (displaying thumbnail in 3×2) or [NORMAL] (displaying thumbnail in 4×3). This item is set to [NORMAL] in the factory settings.  |   |  |
| [PLAYBACK RESUME]  | Select a position to restart playback after stopping playback on the thumbnail screen using the <STOP> button.   |   |  |
|  | [ON]   | Playback starts from the stop position.   |  |
|  | [OFF]  | Playback starts from the beginning of the clip indicated by the pointer.                    |  |
| If the pointer is moved after stopping playback, playback will restart from the beginning of the clip where the pointer is placed regardless of the setting of the [PLAYBACK RESUME] item. Also, attempting to play back from the end of all the available clips will cause the screen to flash momentarily, indicating that there are no more clips which can be played back. |  |   |  |
| [THUMBNAIL INIT]   | Return the above thumbnail display settings to the factory settings. Move the cursor to the [THUMBNAIL INIT] item, and press the <SET> button. Select [YES] when the confirmation screen is displayed.   |   |  |
| [EXIT]   | Return to the previous menu.   |   |  |

**Properties**

Clip properties and P2 card status are displayed.

It is possible to edit and rewrite recorded clip metadata while clip properties are displayed.

**Clip properties**

Select [PROPERTY] → [CLIP PROPERTY] from the thumbnail menu. The following screen appears.

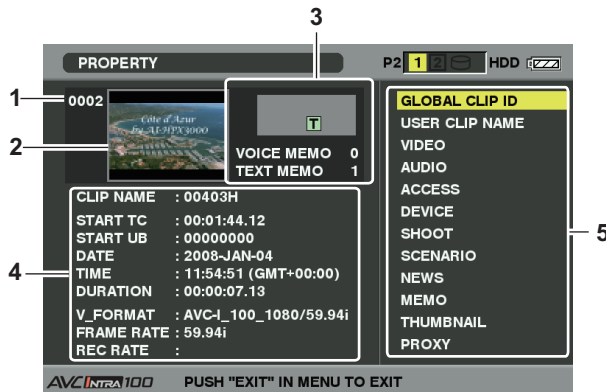

**1** Clip number

**NOTE**

- For clips that cannot be played back, the number is displayed in red.
- When the [EVF TYPE] item on the setting menu [DISPLAY SETUP] screen is set to [B/W], the [ ] Not playable clip indicator is displayed.

**2** Thumbnail

**3** Clip information

Displays the indicators added to the clip and the number of text and voice memos added to the clip.

The [ ] mark appears if the clip is recorded on a write-protected P2 card.

**NOTE**

- The camera is not capable of recording or playing back voice memos.



**4 Clip information**

Displays detailed information about the clip.

|             |   |
|-------------|---|
| [CLIP NAME] | Displays clip names.  |
| [START TC]  | Displays the time code value at the start of the recording. |
| [START UB]  | Displays the user bit value at the start of the recording.  |
| [DATE]      | Displays the date of the recording.                         |
| [TIME]      | Displays the time at the start of recording.                |
| [DURATION]  | Displays the time length of the clip.                       |

|              |   |
|--------------|---|
| [V_FORMAT]   | Displays recording format of the clip.  |
| [FRAME RATE] | Displays the frame rate for playback.   |
| [REC RATE]   | Displays the recording frame rate. (Only displayed when using the variable frame rate recording function to record in native mode.) |

**5 Clip metadata**

Displays more detailed data about the clip. Move the pointer using the cursor buttons, and press the <SET> button to check the detailed content.

For details, refer to “Setting clip metadata” (page 108).

**Modifying recorded clip metadata**

**1** Display the metadata details window for the clip to be modified on the clip properties screen.

**2** Place the cursor on the item to be modified using the cursor buttons.

The metadata that can be modified is shown like [CREATOR] in the following figure.



**4** Press the [OK] button on the keyboard.

The modified metadata is written on the clip and the screen returns to the metadata details window.

**NOTE**

- To delete each item in [LOCATION] (shooting location data) of [SHOOT], the item cannot be deleted alone. By setting the [ALTITUDE] item to empty, other [LONGITUDE] and [LATITUDE] items are collectively deleted.
- The metadata for a clip with the [ ] incomplete clip indicator cannot be modified. For the clips recorded on multiple P2 cards, modify the metadata while all P2 cards are inserted.
- Any [MEMO] with 101 characters or more cannot be modified.

**3** Press the <SET> button.

Information about keyboard operation is the same as “Checking and modifying uploaded metadata” (page 109).

- The input window (soft keyboard) for modifying metadata is displayed.
- Input characters from the keyboard to modify the metadata.

**P2 card status display**

■ **P2 card status display settings**

For the P2 card status displayed by selecting [PROPERTY] → [CARD STATUS] from the thumbnail menu, you can select whether to display the status with P2 card remaining capacity or used memory capacity.

**1** Press the <THUMBNAİL> button.

The thumbnail screen appears on the viewfinder screen.

**2** Select [PROPERTY] → [PROPERTY SETUP] → [P2 CARD CAP] from the thumbnail menu.

When the following screen appears, select the P2 card status display setting from the [P2 CARD CAP] item.



|        |   |
|--------|---|
| [USED] | Displays used memory capacity on the P2 card as the P2 card status display. |
|--------|---|

|          |   |
|----------|---|
| [REMAIN] | Displays remaining capacity on the P2 card as the P2 card status display. (Factory setting) |
|----------|---|

**Contents of P2 card status display settings**

Select [PROPERTY] → [CARD STATUS] from the thumbnail menu. The following screen appears.

■ When [REMAIN] is selected

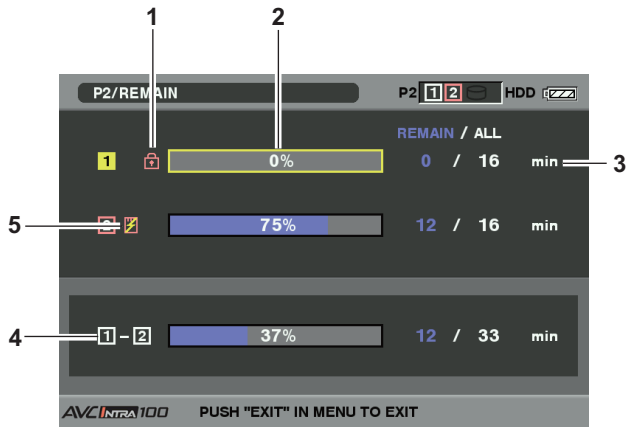

**1 Write-protect mark**

The mark appears if the P2 card is write-protected.

**2 P2 card status (remaining capacity)**

The remaining memory capacity of the P2 card is shown as a bar graph and percentage. The bar graph indicator moves to the left as the remaining capacity decreases.

The following displays may appear, depending on the card status.

|                  |  |
|------------------|--|
| [FORMAT ERROR!]  | An unformatted P2 card is inserted.            |
| [NOT SUPPORTED!] | An unsupported card is inserted in the camera. |
| [NO CARD]        | No P2 card is inserted.                        |

Use the cursor buttons to place the cursor on the P2 card for data to be accessed and press the <SET> button to display detailed information about the P2 card to check specific information such as the serial number and the user ID.

**3 P2 card remaining capacity/total capacity**

Displays the P2 card remaining capacity and total capacity. The units are minutes. Because only the figures in minutes are displayed, the total remaining memory capacity for each P2 card may not match the total remaining memory capacity.

**4 Total remaining capacity for the slot**

Displays the total remaining capacity for all two slots. However, the remaining capacity of a write-protected P2 card is not included in the total available space.

**5 Warning mark**

When the following P2 cards are detected, the mark is displayed.

|                     |  |
|---------------------|--|
| [RUN DOWN CARD]     | The maximum number of overwrites on the P2 card has been exceeded. |
| [DIR ENTRY NG CARD] | The directory structure on the P2 card is not supported.           |

The warning can be confirmed on the P2 card detailed information display in "P2 card status (remaining capacity)" (page 114).

■ When [USED] is selected

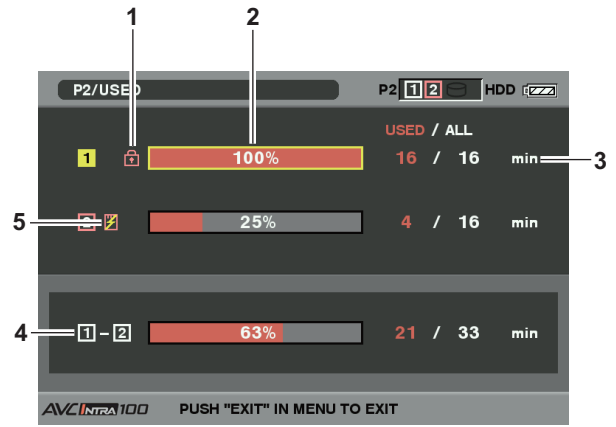

**1 Write-protect mark**

The mark appears if the P2 card is write-protected.

**2 P2 card status (used memory capacity)**

The used memory capacity of the P2 card is shown as a bar graph and percentage. The bar graph indicator moves to the right as the used memory capacity increases.

The following displays may appear, depending on the card status.

|                  |  |
|------------------|--|
| [FORMAT ERROR!]  | An unformatted P2 card is inserted.            |
| [NOT SUPPORTED!] | An unsupported card is inserted on the camera. |
| [NO CARD]        | No P2 card is inserted.                        |

Use the cursor buttons to place the cursor on the P2 card for data to be accessed and press the <SET> button to display detailed information about the P2 card to check specific information such as the serial number and the user ID.

**3 P2 card used memory capacity/total capacity**

Displays the P2 card used memory capacity and total capacity. The units are minutes. Because only the figures in minutes are displayed, the total used memory capacity for each P2 card may not match the total memory capacity.

The used memory capacity of a write-protected P2 card is displayed as 100%.

**4 Total used memory capacity for all slots**

Displays the total used memory capacity for all two slots.

**5 Warning mark**

When the following P2 cards are detected, the mark is displayed.

|                     |  |
|---------------------|--|
| [RUN DOWN CARD]     | The maximum number of overwrites on the P2 card has been exceeded. |
| [DIR ENTRY NG CARD] | The directory structure on the P2 card is not supported.           |

The warning can be confirmed on the P2 card detailed information display in "P2 card status (used memory capacity)" (page 114).

**SD memory card status display**

The status display enables confirmation of the SD memory card format condition, available memory space, etc.

Select [PROPERTY] → [DEVICES] → [SD CARD] from the thumbnail menu.

|                  |   |
|------------------|---|
| [SD STANDARD]    | Indicates whether an SD memory card is formatted according to the SD/SDHC standard. <ul style="list-style-type: none"> <li>• [SUPPORTED]: Complies with SD/SDHC</li> <li>• [NOT SUPPORTED]: Does not comply with SD/SDHC</li> </ul> |
| [USED]           | Used capacity (bytes)   |
| [BLANK]          | Available space (bytes)   |
| [TOTAL]          | Total capacity (bytes)  |
| [PROXY REM]      | Remaining capacity in proxy recording (displayed only when the video encoder board is installed)  |
| [NUMBER OF CLIP] | The number of clips on an SD memory card when clips have been copied to an SD memory card   |
| [PROTECT]        | Write protected   |

## Chapter 7 **Menu Operations**

---

This chapter describes how to operate the camera menus, the structure, and details of the setting menu.

## Displaying the setting menu on the viewfinder screen

### Setting menu basic operations

You can change camera settings using the setting menu according to the shooting scene and recording details.

- When the thumbnail setting menu is displayed, press the <THUMBNAIL> button to close the menu.
- Setting menu items displayed in blue characters are not available.

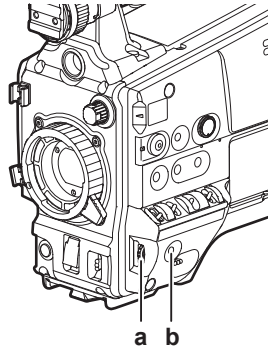

a: Jog dial button

b: <MENU> button

#### 1 Press the <MENU> button when not recording.

- Keep pressing the <MENU> button for approximately one second.
- The setting menu screen appears on the viewfinder screen.

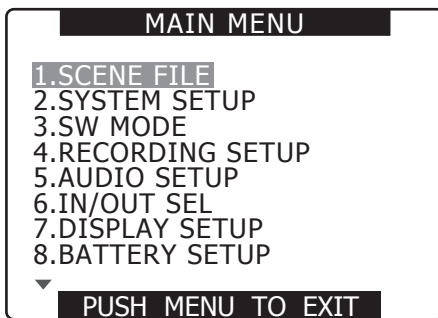

#### 2 With the jog dial button, move the highlight to the function to be set.

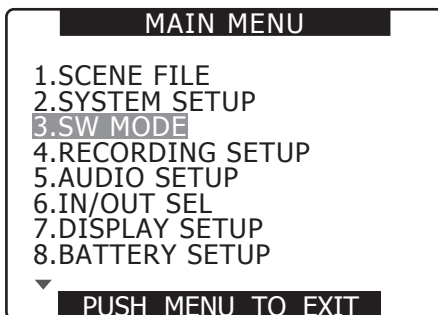

#### 3 Press the jog dial button to display the item to set.

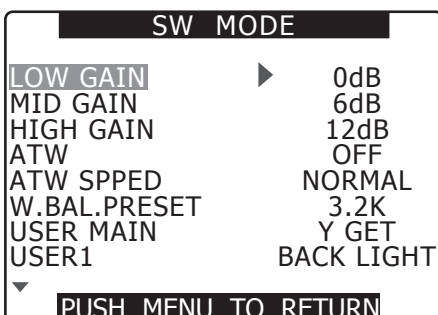

#### 4 With the jog dial button, move the highlight to the item to be set.

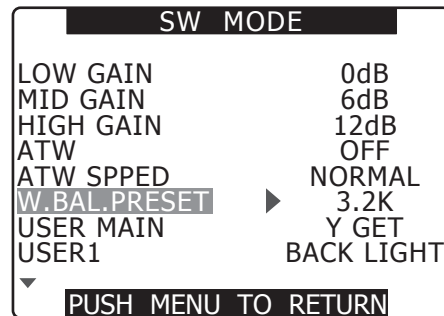

#### 5 Press the jog dial button to set the item.

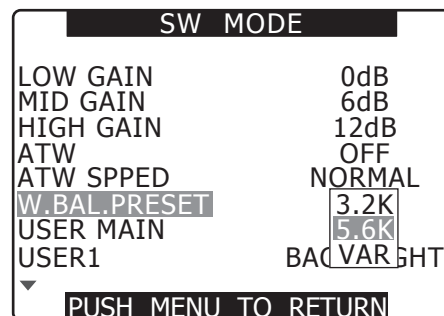

#### 6 Repeat steps 4 to 5 to change other menu items.

To exit the settings, press the <MENU> button to return to the setting menu screen.

#### 7 To change other functions, repeat steps 2 to 5.

Press the <MENU> button to close the function setting menu and return to the normal screen.

### Menu direct close function

After setting the menu, press and hold the <MENU> button to directly close the setting menu screen.

### Changing setting values quickly (only for [MASTER PED] and [H PHASE])

Fast up

- Press and turn up the jog dial button, and keep pressing it at the position.

Fast down

- Press and turn down the jog dial button, and keep pressing it at the position.

### Initializing the setting menu items

Set items are saved divided into user files and scene files. Both of the files can be initialized to the factory settings.

#### Initializing user files (all setting items other than scene files)

By selecting [INITIAL] in the [USER FILE] item of the [OTHER FUNCTIONS] screen, you can restore the current user file menu setting to its factory setting.

#### Initializing [SCENE FILE]

Among six scene files, select the scene file to be initialized from the [CAM02:SCENE FILE] screen of SmartUI. Then by selecting [INITIAL] on the [LOAD/SAVE/INIT] item of the [SCENE FILE] screen, you can restore the setting value of the selected scene file to its factory setting.

- Scene files other than the current scene file number are not affected.

#### Initializing user files and scene files concurrently

By selecting [YES] in the [MENU INIT] item of the [OTHER FUNCTIONS] screen, you can restore the user files and all six scene files to their factory settings.

## Setting menu structure

The setting menu structure list indicates restrictions as follows.

|       |   |
|-------|---|
| (OP1) | Available when the video encoder board AG-YDX600G (extra-cost option) is mounted.                                     |
| (OP2) | Available when the HD/SD SDI input board AG-YA600G (extra-cost option) is mounted.                                    |
| (OP3) | Available when the upgrade software key AG-SFU601G (network function (extra-cost option)) is installed.               |
| (OP4) | Available when the upgrade software key AG-SFU602G (production package (extra-cost option)) is installed.             |
| (OP5) | Available when the Upgrade Software Key AG-SFU603G (UPLINK device control function (extra-cost option)) is installed. |
| (OP6) | Available when the Upgrade Software Key AG-SFU604G (Playlist edit function (extra-cost option)) is installed.         |

When any of those options are not introduced, the corresponding items in the menu are grayed out and cannot be selected.

### MAIN MENU

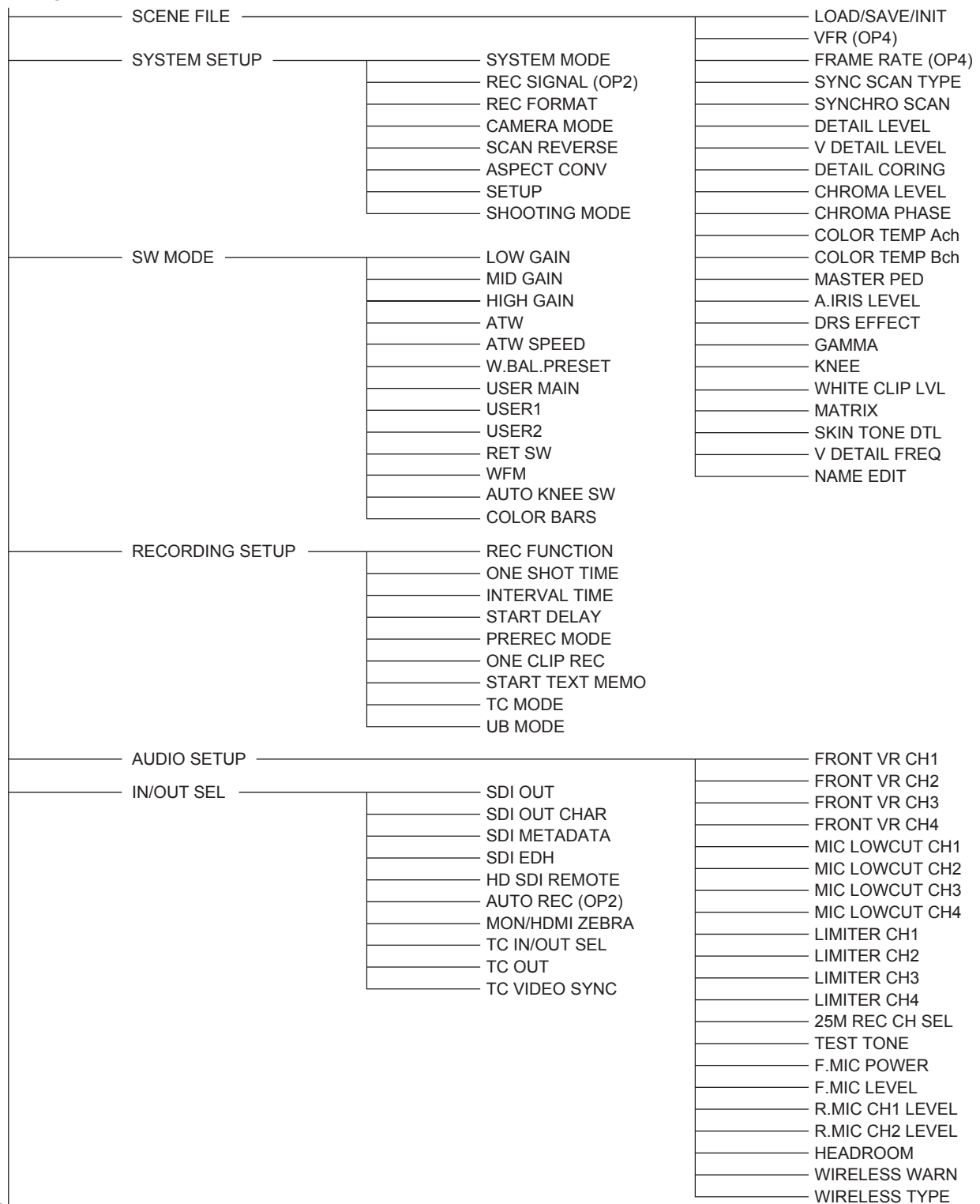

Continued on next page

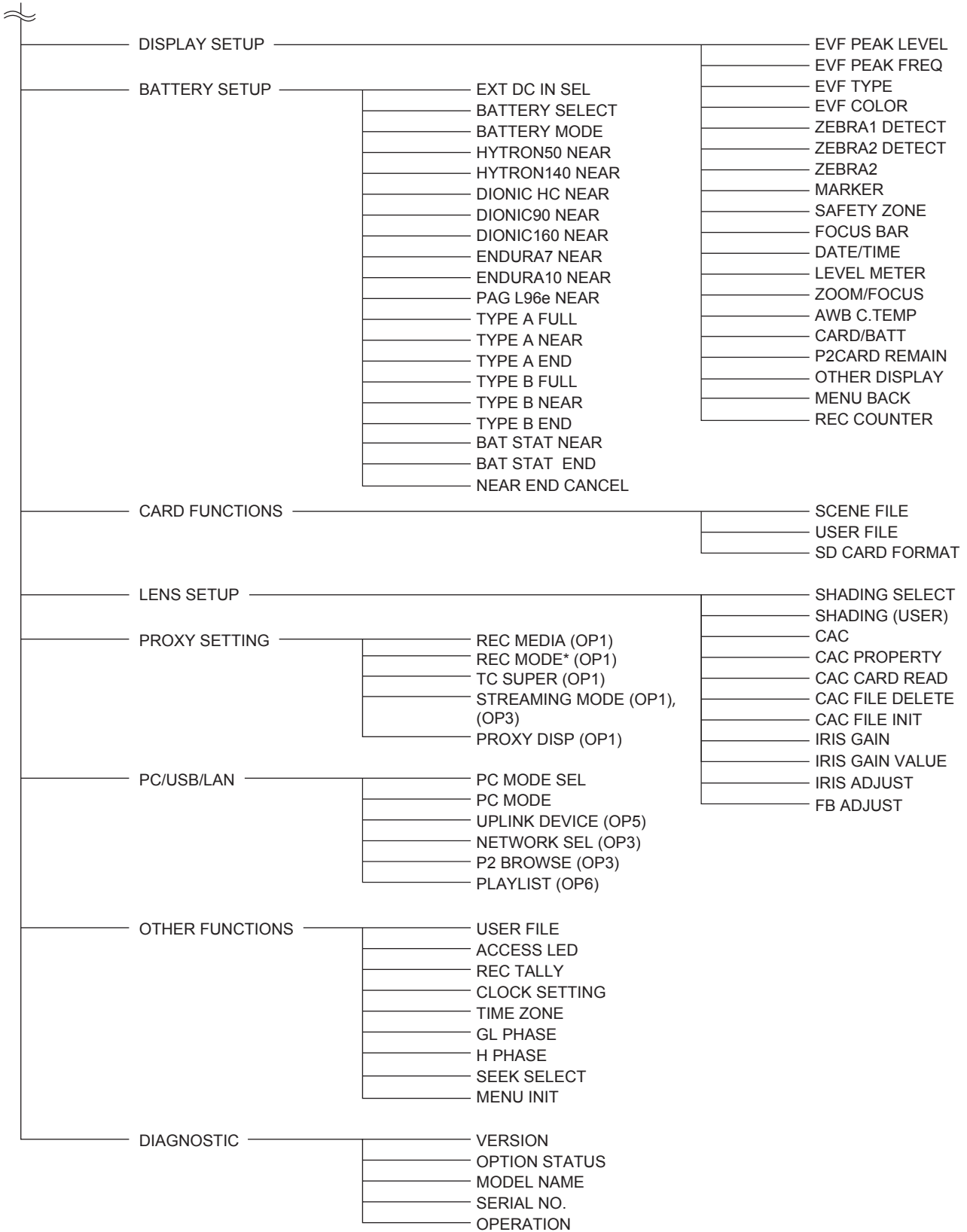

\* For [REC MODE], [REC MODE (1080)], [REC MODE (720)], or [REC MODE (SD)] is displayed when the system mode is 1080 mode, 720 mode, or SD mode, respectively.

## Menu list

### [SCENE FILE] screen

| Item             | Description of settings   | Remark  |   |
|------------------|---|---|---|
| LOAD/SAVE/INIT   | Loads, saves, or initializes the setting value of the scene file assigned to the current scene file number (one number among F1 to F6).   | <ul style="list-style-type: none"> <li>• This setting change does not affect the scene files other than the current scene file number.</li> <li>• This setting is not available when clip connection is underway with one-clip recording.</li> </ul>  |   |
|                  | <b>[LOAD]</b>   |   | Loads data saved in the built-in memory of the camera.  |
|                  | <b>[SAVE]</b>   |   | Saves the current value in the built-in memory of the camera.   |
|                  | <b>[INITIAL]</b>  |   | Returns to the factory settings.  |
| VFR (OP4)        | Sets whether to allow variable frame rate (VFR).  | <ul style="list-style-type: none"> <li>• This setting is not displayed when [SYSTEM MODE] is [480i], [576i], and [1080-23.98PsF].</li> <li>• This setting is not available when [SYSTEM MODE] is [1080i] and an item other than [60i] and [50i] is selected at [CAMERA MODE].</li> <li>• This setting is not available when [REC SIGNAL] is [SDI IN].</li> <li>• The screen may be disturbed momentarily when switched to 24 frames.</li> <li>• This item can also be set on the [CAM03:SETUP] screen of SmartUI</li> </ul> |   |
|                  | <b>[ON]</b>   |   | Activates the variable frame rate.  |
|                  | <b>[OFF]</b>  |   | Does not activate the variable frame rate.  |
| FRAME RATE (OP4) | Selects shooting interval and exposure time when the [VFR] item is [ON] in [1080i] and [720P].  |   |   |
|                  | <b>[1080-59.94i]</b>  |   | Variable from [1] up to [30] frames (17 steps)<br>[1], [2], [4], [6], [9], [12], [15], [18], [20], [21], [22], [24], [25], [26], [27], [28], [30]   |
|                  | <b>[1080-50i]</b>   |   | Variable from [1] up to [25] frames (14 steps)<br>[1], [2], [4], [6], [9], [12], [15], [18], [20], [21], [22], [23], [24], [25]   |
|                  | <b>[720-59.94P]</b>   |   | Variable from [1] up to [60] frames (25 steps)<br>[1], [2], [4], [6], [9], [12], [15], [18], [20], [21], [22], [24], [25], [26], [27], [28], [30], [32], [34], [36], [40], [44], [48], [54], [60] |
|                  | <b>[720-50P]</b>  |   | Variable from [1] up to [50] frames (25 steps)<br>[1], [2], [4], [6], [9], [12], [15], [18], [20], [21], [22], [23], [24], [25], [26], [27], [28], [30], [32], [34], [37], [42], [45], [48], [50] |
| SYNC SCAN TYPE   | Selects the synchro scan display setting.<br><b>[sec], [deg]</b>  |   |   |
| SYNCHRO SCAN     | Displays the synchro scan shutter speed used for TV screen shooting. Continuous pressing of the jog dial button turned up or down will accelerate the speed to change the setting value. (page 56)  |   |   |
|                  | ■ When [SYNC SCAN TYPE] is [sec]  |   |   |
|                  | [60i], [60P]  |   | [1/60.0] to [1/249.8] seconds   |
|                  | [30P]   |   | [1/30.0] to [1/249.8] seconds   |
|                  | [24P]   |   | [1/24.0] to [1/249.8] seconds   |
|                  | [50i], [50P]  |   | [1/50.0] to [1/250.0] seconds   |
|                  | [25P]   |   | [1/25.0] to [1/250.0] seconds   |
|                  | ■ When [SYNC SCAN TYPE] is [deg]  |   |   |
|                  | <b>When the [VFR] item is [OFF]</b><br>Can be set with [3d] to [360d], and [0.5d] steps.  |   |   |
|                  | <b>When the [VFR] item is [ON] (OP4)</b><br>Setting of the [FRAME RATE] item is more than 12P<br>Can be set with [3d] to [360d], and [0.5d] steps.<br>Setting of the [FRAME RATE] item is less than 12P<br>Can be set with [3d] to [22.5d], and [0.5d] steps.<br>[45d], [90d], [180d], [360d] |   |   |
| DETAIL LEVEL     | Adjusts the level of the image outline correction (in the horizontal and vertical directions).<br><b>[-7] ... [0] ... [+7]</b>  |   |   |
| V DETAIL LEVEL   | Adjusts the level of outline correction in the vertical direction.<br><b>[-7] ... [0] ... [+7]</b>  |   |   |
| DETAIL CORING    | Adjusts the level of noise reduction of the detail signal.<br><b>[-7] ... [0] ... [+7]</b> <ul style="list-style-type: none"> <li>• Setting in the - direction results in a clearer image, but increases noise slightly.</li> <li>• Setting in the + direction reduces noise.</li> </ul>      |   |   |
| CHROMA LEVEL     | Adjusts the chroma level.<br><b>[-7] ... [0] ... [+7]</b>   |   |   |
| CHROMA PHASE     | Makes fine adjustments to the chroma phase.<br><b>[-7] ... [0] ... [+7]</b>   |   |   |
| COLOR TEMP Ach   | Makes fine adjustments to the color temperature (after white balance Ach adjustment).<br><b>[-7] ... [0] ... [+7]</b>   |   |   |
| COLOR TEMP Bch   | Makes fine adjustments to the color temperature (after white balance Bch adjustment).<br><b>[-7] ... [0] ... [+7]</b>   |   |   |

\_\_\_\_\_ indicates the factory setting value of scene file number F1.



## Chapter 7 Menu Operations — Menu list

| Item                | Description of settings  | Remark   |  |                |  |                  |   |  |   |                  |  |                     |   |                     |  |  |
|---------------------|--|--|--|----------------|--|------------------|---|--|---|------------------|--|---------------------|---|---------------------|--|--|
| MASTER PED          | Adjusts the master pedestal (black level of the image) as the basis for images.<br>[-100] ... [+12] ... [+100]   | <ul style="list-style-type: none"> <li>Press and turn up or down the jog dial button, and keep pressing it at the position to change the value faster.</li> <li>When the remote control unit (AJ-RC10G) or the extension control unit (AG-EC4G) is connected, make adjustments with the M-PED volume of the remote control unit or the extension control unit.</li> </ul>                              |  |                |  |                  |   |  |   |                  |  |                     |   |                     |  |  |
| A. IRIS LEVEL       | Sets the desired auto iris level.<br>[-10] ... [0] ... [+10]   |  |  |                |  |                  |   |  |   |                  |  |                     |   |                     |  |  |
| DRS EFFECT          | Sets the compression level for the high-brightness areas of the dynamic range stretcher function.<br>It enables the dynamic range to be expanded by compressing the level of the video signals in the high-brightness areas where overexposure results during normal shooting.<br>[1], [2], [3]<br><ul style="list-style-type: none"> <li>The higher the value of the setting, the higher the compression level of the high-brightness areas and the level of noise in dark areas.</li> </ul>  | <ul style="list-style-type: none"> <li>When 1080i and progressive mode are set, the dynamic range stretcher function is not activated even if [DRS EFFECT] is set.</li> <li>Set the [AUTO KNEE SW] item on the [SW MODE] screen is set to [DRS] and push the &lt;OUTPUT&gt;/&lt;AUTO KNEE&gt; selector switch towards the &lt;ON&gt; side to activate the dynamic range stretcher function.</li> </ul> |  |                |  |                  |   |  |   |                  |  |                     |   |                     |  |  |
| GAMMA               | <p>Selects the gamma curve.</p> <table border="1" style="width: 100%; border-collapse: collapse;"> <tr> <td style="width: 15%;"><b>[HD NORM]</b></td> <td>Suitable for HD shooting.</td> </tr> <tr> <td><b>[LOW]</b></td> <td>Makes a mellow image using a gamma curve that has a gentle incline in low-brightness curve. The contrast sharpens.</td> </tr> <tr> <td><b>[SD NORM]</b></td> <td>This is the normal video setting carried over from the DVX100 series.</td> </tr> <tr> <td><b>[HIGH]</b></td> <td>Expands the tone of dark parts and makes a brighter image using a gamma curve that has a sharp incline in low-brightness curve. The contrast softens.</td> </tr> <tr> <td><b>[B.PRESS]</b></td> <td>Makes the contrast sharper than [LOW].</td> </tr> <tr> <td><b>[CINELIKE D]</b></td> <td>Uses a gamma curve designed to create cinema-like images.</td> </tr> <tr> <td><b>[CINELIKE V]</b></td> <td>Uses a gamma curve designed to create cinema-like images with emphasized contrast.</td> </tr> </table> <ul style="list-style-type: none"> <li>When you select [CINE-LIKE] gamma, we recommend setting the lens aperture lower than normal image level (approximately 1/2) for optimal results.</li> </ul> | <b>[HD NORM]</b>   | Suitable for HD shooting.                                      | <b>[LOW]</b>   | Makes a mellow image using a gamma curve that has a gentle incline in low-brightness curve. The contrast sharpens. | <b>[SD NORM]</b> | This is the normal video setting carried over from the DVX100 series. | <b>[HIGH]</b>  | Expands the tone of dark parts and makes a brighter image using a gamma curve that has a sharp incline in low-brightness curve. The contrast softens. | <b>[B.PRESS]</b> | Makes the contrast sharper than [LOW]. | <b>[CINELIKE D]</b> | Uses a gamma curve designed to create cinema-like images. | <b>[CINELIKE V]</b> | Uses a gamma curve designed to create cinema-like images with emphasized contrast. | <ul style="list-style-type: none"> <li>While the dynamic range stretcher function is activated and when the [CAMERA] item is set to [CINE-LIKE], images are not changed even if the setting is changed.</li> </ul> |
| <b>[HD NORM]</b>    | Suitable for HD shooting.  |  |  |                |  |                  |   |  |   |                  |  |                     |   |                     |  |  |
| <b>[LOW]</b>        | Makes a mellow image using a gamma curve that has a gentle incline in low-brightness curve. The contrast sharpens.   |  |  |                |  |                  |   |  |   |                  |  |                     |   |                     |  |  |
| <b>[SD NORM]</b>    | This is the normal video setting carried over from the DVX100 series.  |  |  |                |  |                  |   |  |   |                  |  |                     |   |                     |  |  |
| <b>[HIGH]</b>       | Expands the tone of dark parts and makes a brighter image using a gamma curve that has a sharp incline in low-brightness curve. The contrast softens.  |  |  |                |  |                  |   |  |   |                  |  |                     |   |                     |  |  |
| <b>[B.PRESS]</b>    | Makes the contrast sharper than [LOW].   |  |  |                |  |                  |   |  |   |                  |  |                     |   |                     |  |  |
| <b>[CINELIKE D]</b> | Uses a gamma curve designed to create cinema-like images.  |  |  |                |  |                  |   |  |   |                  |  |                     |   |                     |  |  |
| <b>[CINELIKE V]</b> | Uses a gamma curve designed to create cinema-like images with emphasized contrast.   |  |  |                |  |                  |   |  |   |                  |  |                     |   |                     |  |  |
| KNEE                | <p>To avoid overexposure, select the compression level (knee point) of the high intensity video signals received through the MOS sensor.</p> <table border="1" style="width: 100%; border-collapse: collapse;"> <tr> <td style="width: 15%;"><b>[HIGH]</b></td> <td>High setting (Compression starts at approx. 100%)</td> </tr> <tr> <td><b>[MID]</b></td> <td>Medium setting (Compression starts at approx. 90%)</td> </tr> <tr> <td><b>[LOW]</b></td> <td>Low setting (Compression starts at approx. 80%)</td> </tr> </table>   | <b>[HIGH]</b>  | High setting (Compression starts at approx. 100%)              | <b>[MID]</b>   | Medium setting (Compression starts at approx. 90%)   | <b>[LOW]</b>     | Low setting (Compression starts at approx. 80%)                       | <ul style="list-style-type: none"> <li>While the dynamic range stretcher function is activated, images do not change when the setting is changed.</li> <li>To set the knee point automatically according to the signals received, use the &lt;AUTO KNEE&gt; switch.</li> </ul> |   |                  |  |                     |   |                     |  |  |
| <b>[HIGH]</b>       | High setting (Compression starts at approx. 100%)  |  |  |                |  |                  |   |  |   |                  |  |                     |   |                     |  |  |
| <b>[MID]</b>        | Medium setting (Compression starts at approx. 90%)   |  |  |                |  |                  |   |  |   |                  |  |                     |   |                     |  |  |
| <b>[LOW]</b>        | Low setting (Compression starts at approx. 80%)  |  |  |                |  |                  |   |  |   |                  |  |                     |   |                     |  |  |
| WHITE CLIP LVL      | Sets the white clip level.<br>[100%] - [109%] (by units of [1%])   |  |  |                |  |                  |   |  |   |                  |  |                     |   |                     |  |  |
| MATRIX              | <p>Selects the matrix table suitable for the desired color expression during shooting.</p> <table border="1" style="width: 100%; border-collapse: collapse;"> <tr> <td style="width: 15%;"><b>[NORM1]</b></td> <td>Suitable for shooting in the open air or under a halogen lamp.</td> </tr> <tr> <td><b>[NORM2]</b></td> <td>Suitable for brighter colors than the [NORM1] mode.</td> </tr> <tr> <td><b>[FLUO]</b></td> <td>Suitable for shooting under fluorescent lights indoors.</td> </tr> <tr> <td><b>[CINE-LIKE]</b></td> <td>Suitable for shooting cinema-like images.</td> </tr> </table>   | <b>[NORM1]</b>   | Suitable for shooting in the open air or under a halogen lamp. | <b>[NORM2]</b> | Suitable for brighter colors than the [NORM1] mode.  | <b>[FLUO]</b>    | Suitable for shooting under fluorescent lights indoors.               | <b>[CINE-LIKE]</b>   | Suitable for shooting cinema-like images.   |                  |  |                     |   |                     |  |  |
| <b>[NORM1]</b>      | Suitable for shooting in the open air or under a halogen lamp.   |  |  |                |  |                  |   |  |   |                  |  |                     |   |                     |  |  |
| <b>[NORM2]</b>      | Suitable for brighter colors than the [NORM1] mode.  |  |  |                |  |                  |   |  |   |                  |  |                     |   |                     |  |  |
| <b>[FLUO]</b>       | Suitable for shooting under fluorescent lights indoors.  |  |  |                |  |                  |   |  |   |                  |  |                     |   |                     |  |  |
| <b>[CINE-LIKE]</b>  | Suitable for shooting cinema-like images.  |  |  |                |  |                  |   |  |   |                  |  |                     |   |                     |  |  |
| SKIN TONE DTL       | Switches skin tone details [ON]/[OFF].<br>Select [ON] to reduce the skin tone details and soften the skin tone.<br>[ON], [OFF]   |  |  |                |  |                  |   |  |   |                  |  |                     |   |                     |  |  |
| V DETAIL FREQ       | <p>Sets the vertical detail.</p> <table border="1" style="width: 100%; border-collapse: collapse;"> <tr> <td style="width: 15%;"><b>[THIN]</b></td> <td>Makes the detail thin.</td> </tr> <tr> <td><b>[MID]</b></td> <td>Makes the detail slightly thick.</td> </tr> <tr> <td><b>[THICK]</b></td> <td>Makes the detail thick.</td> </tr> </table> <ul style="list-style-type: none"> <li>When images shot with the [THIN] or [MID] setting in progressive mode are played back on a usual TV monitor (60i: interlaced), you will sense flicker on horizontal lines and nearly-horizontal diagonal lines. When playing back in progressive environment, or performing post-processing such as edit, set this item to [THIN] or [MID] to obtain images with higher resolution than the images of [THICK] setting.</li> </ul>   | <b>[THIN]</b>  | Makes the detail thin.   | <b>[MID]</b>   | Makes the detail slightly thick.   | <b>[THICK]</b>   | Makes the detail thick.   |  |   |                  |  |                     |   |                     |  |  |
| <b>[THIN]</b>       | Makes the detail thin.   |  |  |                |  |                  |   |  |   |                  |  |                     |   |                     |  |  |
| <b>[MID]</b>        | Makes the detail slightly thick.   |  |  |                |  |                  |   |  |   |                  |  |                     |   |                     |  |  |
| <b>[THICK]</b>      | Makes the detail thick.  |  |  |                |  |                  |   |  |   |                  |  |                     |   |                     |  |  |
| NAME EDIT           | Edits the name of the scene file selected on the [CAM02:SCENE FILE] screen of SmartUI.   |  |  |                |  |                  |   |  |   |                  |  |                     |   |                     |  |  |

\_\_\_\_\_ indicates the factory setting value of scene file number F1.

**[SYSTEM SETUP] screen**

| Item   | Description of settings  | Remark  |  |   |   |  |  |  |  |   |   |  |  |  |   |   |   |                |  |   |
|--|--|---|--|---|---|--|--|--|--|---|---|--|--|--|---|---|---|----------------|--|---|
| SYSTEM MODE                                      | Sets the signal format of the camera.<br>[1080-59.94i], [1080-23.98PsF] (OP4), [1080-50i], [720-59.94P], [720-50P], [480-59.94i], [576-50i]<br>• [TURN POWER OFF] is displayed when the setting is changed. Turn off the power of the camera once, and turn it on again.   | <ul style="list-style-type: none"> <li>• This setting is not available in USB device mode.</li> <li>• This setting is not available when clip connection is underway with one-clip recording.</li> <li>• The factory settings may differ depending on the region.<br/>(AG-HPX610P: [1080-59.94i], AG-HPX610EJ: [1080-50i])</li> <li>• When OP4 is not installed<br/>The [1080-23.98PsF] setting item is grayed out and cannot be selected.</li> </ul> |  |   |   |  |  |  |  |   |   |  |  |  |   |   |   |                |  |   |
| REC SIGNAL (OP2)                                 | <p>Selects the input signal. The [SDI IN] item can be selected when the HD/SD SDI input board (extra-cost option) is installed.</p> <table border="1"> <tr> <td>[CAMERA]</td> <td>Records camera shooting signals of the camera.</td> </tr> <tr> <td>[SDI IN]</td> <td>Records input signals to &lt;SDI OUT/IN (OP)&gt; terminal.</td> </tr> </table> <ul style="list-style-type: none"> <li>• It is always set to [CAMERA] when the power is turned on.</li> </ul>  | [CAMERA]  | Records camera shooting signals of the camera.   | [SDI IN]                                      | Records input signals to <SDI OUT/IN (OP)> terminal.  | <ul style="list-style-type: none"> <li>• This item is not displayed when [SYSTEM MODE] is [1080-23.98PsF].</li> <li>• When [SDI IN] is selected, images are recorded with 60i or 50i regardless of the [REC FORMAT] setting.</li> <li>• This setting is not available when clip connection is underway with one-clip recording.</li> </ul> |  |  |  |   |   |  |  |  |   |   |   |                |  |   |
| [CAMERA]   | Records camera shooting signals of the camera.   |   |  |   |   |  |  |  |  |   |   |  |  |  |   |   |   |                |  |   |
| [SDI IN]   | Records input signals to <SDI OUT/IN (OP)> terminal.   |   |  |   |   |  |  |  |  |   |   |  |  |  |   |   |   |                |  |   |
| REC FORMAT                                       | <p>Selects the recording codec, and shooting and recording modes.</p> <p>■ When [SYSTEM MODE] is [1080-59.94i]</p> <table border="1"> <tr> <td>[AVC-I100/60i], [AVC-I100/30PN], [AVC-I100/24PN]</td> <td>Recorded using the AVC-I 100 codec. 60i, 30PN (native recording), and 24PN (native recording) are used for shooting and recording, respectively.</td> </tr> <tr> <td>[AVC-I50/60i], [AVC-I50/30PN], [AVC-I50/24PN]</td> <td>Recorded using the AVC-I 50 codec. 60i, 30PN (native recording), and 24PN (native recording) are used for shooting and recording, respectively.</td> </tr> <tr> <td>[DVCPROHD/60i]</td> <td>Recorded using the DVCPRO HD codec. Shooting mode can be set at the [CAMERA MODE] item. Recording is fixed to 60i.</td> </tr> </table> <p>■ When [SYSTEM MODE] is [720-59.94P]</p> <table border="1"> <tr> <td>[AVC-I100/60P], [AVC-I100/30PN], [AVC-I100/24PN]</td> <td>Recorded using the AVC-I 100 codec. 60i, 30PN (native recording), and 24PN (native recording) are used for shooting and recording, respectively.</td> </tr> <tr> <td>[AVC-I50/60P], [AVC-I50/30PN], [AVC-I50/24PN]</td> <td>Recorded using the AVC-I 50 codec. 60i, 30PN (native recording), and 24PN (native recording) are used for shooting and recording, respectively.</td> </tr> <tr> <td>[DVCPROHD/60P], [DVCPROHD/30PN], [DVCPROHD/24PN]</td> <td>Recorded using the DVCPRO HD codec. 60P, 30PN (native recording), and 24PN (native recording) are used for shooting and recording, respectively.</td> </tr> </table> <p>■ When [SYSTEM MODE] is [480-59.94i]</p> <table border="1"> <tr> <td>[DVCPRO50/60i], [DVCPRO/60i], [DV/60i]</td> <td>Recorded using the DVCPRO50, DVCPRO, and DV codec, respectively. Shooting mode can be set with the [CAMERA MODE] item. Recording is fixed to 60i.</td> </tr> </table> <p>■ When [SYSTEM MODE] is [1080-23.98PsF] (*OP4)</p> <table border="1"> <tr> <td>[AVC-I100/24PN]</td> <td>Recorded using the AVC-I 100 codec. 24PN (native recording) is used for shooting and recording.</td> </tr> <tr> <td>[AVC-I50/24PN]</td> <td>Recorded using the AVC-I 50 codec. 24PN (native recording) is used for shooting and recording.</td> </tr> </table> | [AVC-I100/60i], [AVC-I100/30PN], [AVC-I100/24PN]  | Recorded using the AVC-I 100 codec. 60i, 30PN (native recording), and 24PN (native recording) are used for shooting and recording, respectively. | [AVC-I50/60i], [AVC-I50/30PN], [AVC-I50/24PN] | Recorded using the AVC-I 50 codec. 60i, 30PN (native recording), and 24PN (native recording) are used for shooting and recording, respectively. | [DVCPROHD/60i]   | Recorded using the DVCPRO HD codec. Shooting mode can be set at the [CAMERA MODE] item. Recording is fixed to 60i.   | [AVC-I100/60P], [AVC-I100/30PN], [AVC-I100/24PN] | Recorded using the AVC-I 100 codec. 60i, 30PN (native recording), and 24PN (native recording) are used for shooting and recording, respectively. | [AVC-I50/60P], [AVC-I50/30PN], [AVC-I50/24PN] | Recorded using the AVC-I 50 codec. 60i, 30PN (native recording), and 24PN (native recording) are used for shooting and recording, respectively. | [DVCPROHD/60P], [DVCPROHD/30PN], [DVCPROHD/24PN] | Recorded using the DVCPRO HD codec. 60P, 30PN (native recording), and 24PN (native recording) are used for shooting and recording, respectively. | [DVCPRO50/60i], [DVCPRO/60i], [DV/60i] | Recorded using the DVCPRO50, DVCPRO, and DV codec, respectively. Shooting mode can be set with the [CAMERA MODE] item. Recording is fixed to 60i. | [AVC-I100/24PN]   | Recorded using the AVC-I 100 codec. 24PN (native recording) is used for shooting and recording. | [AVC-I50/24PN] | Recorded using the AVC-I 50 codec. 24PN (native recording) is used for shooting and recording. | <ul style="list-style-type: none"> <li>• When [REC SIGNAL] is [SDI IN], recording is performed in a normal mode (60i or 60P) even if the native recording is selected.</li> <li>• This setting is not available in USB device mode.</li> <li>• This setting is not available when clip connection is underway with one-clip recording.</li> </ul> |
| [AVC-I100/60i], [AVC-I100/30PN], [AVC-I100/24PN] | Recorded using the AVC-I 100 codec. 60i, 30PN (native recording), and 24PN (native recording) are used for shooting and recording, respectively.   |   |  |   |   |  |  |  |  |   |   |  |  |  |   |   |   |                |  |   |
| [AVC-I50/60i], [AVC-I50/30PN], [AVC-I50/24PN]    | Recorded using the AVC-I 50 codec. 60i, 30PN (native recording), and 24PN (native recording) are used for shooting and recording, respectively.  |   |  |   |   |  |  |  |  |   |   |  |  |  |   |   |   |                |  |   |
| [DVCPROHD/60i]                                   | Recorded using the DVCPRO HD codec. Shooting mode can be set at the [CAMERA MODE] item. Recording is fixed to 60i.   |   |  |   |   |  |  |  |  |   |   |  |  |  |   |   |   |                |  |   |
| [AVC-I100/60P], [AVC-I100/30PN], [AVC-I100/24PN] | Recorded using the AVC-I 100 codec. 60i, 30PN (native recording), and 24PN (native recording) are used for shooting and recording, respectively.   |   |  |   |   |  |  |  |  |   |   |  |  |  |   |   |   |                |  |   |
| [AVC-I50/60P], [AVC-I50/30PN], [AVC-I50/24PN]    | Recorded using the AVC-I 50 codec. 60i, 30PN (native recording), and 24PN (native recording) are used for shooting and recording, respectively.  |   |  |   |   |  |  |  |  |   |   |  |  |  |   |   |   |                |  |   |
| [DVCPROHD/60P], [DVCPROHD/30PN], [DVCPROHD/24PN] | Recorded using the DVCPRO HD codec. 60P, 30PN (native recording), and 24PN (native recording) are used for shooting and recording, respectively.   |   |  |   |   |  |  |  |  |   |   |  |  |  |   |   |   |                |  |   |
| [DVCPRO50/60i], [DVCPRO/60i], [DV/60i]           | Recorded using the DVCPRO50, DVCPRO, and DV codec, respectively. Shooting mode can be set with the [CAMERA MODE] item. Recording is fixed to 60i.  |   |  |   |   |  |  |  |  |   |   |  |  |  |   |   |   |                |  |   |
| [AVC-I100/24PN]                                  | Recorded using the AVC-I 100 codec. 24PN (native recording) is used for shooting and recording.  |   |  |   |   |  |  |  |  |   |   |  |  |  |   |   |   |                |  |   |
| [AVC-I50/24PN]                                   | Recorded using the AVC-I 50 codec. 24PN (native recording) is used for shooting and recording.   |   |  |   |   |  |  |  |  |   |   |  |  |  |   |   |   |                |  |   |
| REC FORMAT                                       | <p>■ When [SYSTEM MODE] is [1080-50i]</p> <table border="1"> <tr> <td>[AVC-I100/50i], [AVC-I100/25PN]</td> <td>Recorded using the AVC-I 100 codec. 50i and 25PN (native recording) are used for shooting and recording, respectively.</td> </tr> <tr> <td>[AVC-I50/50i], [AVC-I50/25PN]</td> <td>Recorded using the AVC-I 50 codec. 50i and 25PN (native recording) are used for shooting and recording, respectively.</td> </tr> <tr> <td>[DVCPROHD/50i]</td> <td>Recorded using the DVCPRO HD codec. Shooting mode can be set with the [CAMERA MODE] item. Recording is fixed to 50i.</td> </tr> </table> <p>■ When [SYSTEM MODE] is [720-50P]</p> <table border="1"> <tr> <td>[AVC-I100/50P], [AVC-I100/25PN]</td> <td>Recorded using the AVC-I 100 codec. 50P and 25PN (native recording) are used for shooting and recording, respectively.</td> </tr> <tr> <td>[AVC-I50/50P], [AVC-I50/25PN]</td> <td>Recorded using the AVC-I 50 codec. 50P and 25PN (native recording) are used for shooting and recording, respectively.</td> </tr> <tr> <td>[DVCPROHD/50P], [DVCPROHD/25PN]</td> <td>Recorded using the DVCPRO HD codec. 50P and 25PN (native recording) are used for shooting and recording, respectively.</td> </tr> </table> <p>■ When [SYSTEM MODE] is [576-50i]</p> <table border="1"> <tr> <td>[DVCPRO50/50i], [DVCPRO/50i], [DV/50i]</td> <td>Recorded using the DVCPRO50, DVCPRO, and DV codec, respectively. Shooting mode can be set with the [CAMERA MODE] item. Recording is fixed to 50i.</td> </tr> </table>   | [AVC-I100/50i], [AVC-I100/25PN]   | Recorded using the AVC-I 100 codec. 50i and 25PN (native recording) are used for shooting and recording, respectively.                           | [AVC-I50/50i], [AVC-I50/25PN]                 | Recorded using the AVC-I 50 codec. 50i and 25PN (native recording) are used for shooting and recording, respectively.                           | [DVCPROHD/50i]   | Recorded using the DVCPRO HD codec. Shooting mode can be set with the [CAMERA MODE] item. Recording is fixed to 50i. | [AVC-I100/50P], [AVC-I100/25PN]                  | Recorded using the AVC-I 100 codec. 50P and 25PN (native recording) are used for shooting and recording, respectively.                           | [AVC-I50/50P], [AVC-I50/25PN]                 | Recorded using the AVC-I 50 codec. 50P and 25PN (native recording) are used for shooting and recording, respectively.                           | [DVCPROHD/50P], [DVCPROHD/25PN]                  | Recorded using the DVCPRO HD codec. 50P and 25PN (native recording) are used for shooting and recording, respectively.                           | [DVCPRO50/50i], [DVCPRO/50i], [DV/50i] | Recorded using the DVCPRO50, DVCPRO, and DV codec, respectively. Shooting mode can be set with the [CAMERA MODE] item. Recording is fixed to 50i. | <ul style="list-style-type: none"> <li>• When [REC SIGNAL] is [SDI IN], recording is performed in a normal mode (50i or 50P) even if the native recording is selected.</li> <li>• This setting is not available in USB device mode.</li> <li>• This setting is not available when clip connection is underway with one-clip recording.</li> </ul> |   |                |  |   |
| [AVC-I100/50i], [AVC-I100/25PN]                  | Recorded using the AVC-I 100 codec. 50i and 25PN (native recording) are used for shooting and recording, respectively.   |   |  |   |   |  |  |  |  |   |   |  |  |  |   |   |   |                |  |   |
| [AVC-I50/50i], [AVC-I50/25PN]                    | Recorded using the AVC-I 50 codec. 50i and 25PN (native recording) are used for shooting and recording, respectively.  |   |  |   |   |  |  |  |  |   |   |  |  |  |   |   |   |                |  |   |
| [DVCPROHD/50i]                                   | Recorded using the DVCPRO HD codec. Shooting mode can be set with the [CAMERA MODE] item. Recording is fixed to 50i.   |   |  |   |   |  |  |  |  |   |   |  |  |  |   |   |   |                |  |   |
| [AVC-I100/50P], [AVC-I100/25PN]                  | Recorded using the AVC-I 100 codec. 50P and 25PN (native recording) are used for shooting and recording, respectively.   |   |  |   |   |  |  |  |  |   |   |  |  |  |   |   |   |                |  |   |
| [AVC-I50/50P], [AVC-I50/25PN]                    | Recorded using the AVC-I 50 codec. 50P and 25PN (native recording) are used for shooting and recording, respectively.  |   |  |   |   |  |  |  |  |   |   |  |  |  |   |   |   |                |  |   |
| [DVCPROHD/50P], [DVCPROHD/25PN]                  | Recorded using the DVCPRO HD codec. 50P and 25PN (native recording) are used for shooting and recording, respectively.   |   |  |   |   |  |  |  |  |   |   |  |  |  |   |   |   |                |  |   |
| [DVCPRO50/50i], [DVCPRO/50i], [DV/50i]           | Recorded using the DVCPRO50, DVCPRO, and DV codec, respectively. Shooting mode can be set with the [CAMERA MODE] item. Recording is fixed to 50i.  |   |  |   |   |  |  |  |  |   |   |  |  |  |   |   |   |                |  |   |

\_\_\_\_\_ indicates factory setting values.

Chapter 7 Menu Operations — Menu list

| Item          | Description of settings   | Remark  |
|---------------|---|---|
| CAMERA MODE   | Sets the camera shooting mode when set to [1080-59.94i], [480-59.94i], [1080-50i], and [576-50i].   | <ul style="list-style-type: none"> <li>• Displayed only when the [SYSTEM MODE] item is set to [1080-59.94i], [1080-50i], [480-59.94i], or [576-50i].</li> <li>• This setting is not available in the following cases: <ul style="list-style-type: none"> <li>- The [REC SIGNAL] item is set to [SDI IN].</li> <li>- The [SYSTEM MODE] item is set to [1080-59.94i], and the [REC FORMAT] item is set to other than [DVCPROHD/60i].</li> <li>- [SYSTEM MODE] is set to [1080-50i], and the [REC FORMAT] item is set to other than [DVCPROHD/50i].</li> <li>- Clip connection is underway with one-clip recording.</li> </ul> </li> </ul> |
|               | <ul style="list-style-type: none"> <li>■ When [SYSTEM MODE] is [1080-59.94i] or [480-59.94i] [60i], [30P], [24P], [24PA]</li> <li>■ When [SYSTEM MODE] is [1080-50i] or [576-50i] [50i], [25P]</li> </ul> |   |
|               |   |   |
| SCAN REVERSE  | Compensates image inversion that occurs when a lens for filming or anamorphic lens is mounted.<br>[ON], [OFF]   |   |
| ASPECT CONV   | Selects aspect ratio for images recorded with 480i or 576i.   | <ul style="list-style-type: none"> <li>• This setting is not available when the [SYSTEM MODE] item is [1080-59.94i], [1080-23.98PsF], [1080-50i], [720-59.94P], or [720-50P].</li> <li>• This setting is not available when clip connection is underway with one-clip recording.</li> </ul>   |
|               | [SIDE CROP] Side-crop mode (Crops the left and right edges.)  |   |
|               | [LETTER BOX] Letterbox mode (Adds black bands at the top and bottom of the image.)  |   |
|               | [SQUEEZE] Squeeze mode (Squeezes images horizontally.)  |   |
| SETUP         | Sets the setup level of video signals for 480i.   | <ul style="list-style-type: none"> <li>• This item is not displayed when the [SYSTEM MODE] item is set to [1080-50i], [720-50P], or [576-50i].</li> </ul>   |
|               | [0%] Composite output and recording setup levels will both be set to 0%.  |   |
|               | [7.5%A] Composite output setup level will be set to 7.5%, while recording setup level will be set to 0%.  |   |
| SHOOTING MODE | Sets the shooting mode according to the shooting environment.<br>• [TURN POWER OFF] is displayed when the setting is changed. Turn off the power of the camera once, and turn it on again.                | <ul style="list-style-type: none"> <li>• If [NORMAL] is selected, the [-3dB] in the [LOW GAIN] item, [MID GAIN] item, and [HIGH GAIN] item of the [SW MODE] screen on the setting menu are displayed in blue. This will operate at [0dB] even when set.</li> <li>Also, the [GAIN:18dB] item assigned to the &lt;USER MAIN&gt;, &lt;USER1&gt;, and &lt;USER2&gt; buttons becomes invalid and deactivated.</li> <li>• [L.L.] displayed when [LOW LIGHT] is selected appears only when the [OTHER DISPLAY] item on the setting menu [DISPLAY SETUP] screen is set to [PARTIAL] or [ALL].</li> </ul>  |
|               | [NORMAL] Select this when shooting in an environment with normal brightness.  |   |
|               | [LOW LIGHT] Select this when shooting in a dark environment.<br>• [L.L.] is displayed on the viewfinder screen.   |   |



\_\_\_\_\_ indicates factory setting values.

[SW MODE] screen

| Item         | Description of settings   | Remark  |
|--------------|---|---|
| LOW GAIN     | Sets the gain value assigned to the L position of the <GAIN> switch.<br>[-3dB], [0dB], [3dB], [6dB], [9dB], [12dB]  |   |
| MID GAIN     | Sets the gain value assigned to the M position of the <GAIN> switch.<br>[-3dB], [0dB], [3dB], [6dB], [9dB], [12dB]  |   |
| HIGH GAIN    | Sets the gain value assigned to the H position of the <GAIN> switch.<br>[-3dB], [0dB], [3dB], [6dB], [9dB], [12dB]  |   |
| ATW          | Assigns the auto tracking white balance function to the <WHITE BAL> switch. (page 54)   | <ul style="list-style-type: none"> <li>• When the &lt;WHITE BAL&gt; switch is set to the &lt;B&gt; position and this menu is set to [Bch], pressing the &lt;USER&gt; buttons (&lt;USER MAIN&gt;/&lt;USER1&gt;/&lt;USER2&gt;) to which the auto tracking white balance function is assigned does not turn off the auto tracking white balance function.</li> </ul> |
|              | [Bch] Activates the auto tracking white balance function when the <WHITE BAL> switch is set to the <B> position.  |   |
|              | [OFF] Does not assign the auto tracking white balance function to the <WHITE BAL> switch.   |   |
| ATW SPEED    | Sets the control speed of the auto tracking white balance.  |   |
|              | [FAST] A slightly faster setting than [NORMAL].   |   |
|              | [NORMAL] Normal setting.  |   |
|              | [SLOW] A slightly slower setting than [NORMAL].   |   |
| W.BAL.PRESET | Sets the color temperature assigned to the <PRST> position of the <WHITE BAL> switch.<br>Each time the <AUTO W/B BAL> switch is pushed towards the <AWB> side, color temperature can be switched to 3200 K, 5600 K, and user-specified variable value.<br>[3.2K], [5.6K], [VAR] | <ul style="list-style-type: none"> <li>• The color temperature when [VAR] is selected is set at the [CAM03:SETUP] screen of SmartUI. It can be set using the jog dial button, by assigning the [F.JOG CT] function to the &lt;USER&gt; button. (page 59)</li> </ul>   |

\_\_\_\_\_ indicates factory setting values.

## Chapter 7 Menu Operations — Menu list

| Item               | Description of settings  | Remark   |  |                 |   |                    |  |  |
|--------------------|--|--|--|-----------------|---|--------------------|--|--|
| USER MAIN          | Sets the function assigned to the <USER MAIN> button. (page 59)<br>[SPOT LIGHT], [BACK LIGHT], [ATW], [ATW LOCK], [GAIN:18dB], [D.ZOOMX2], [D.ZOOMX4], [FBC], [Y GET], [WFM], [F.JOG CT], [PRE REC], [REC REVIEW], [TEXT MEMO], [SHOT MARK], [SLOT SEL], [A.MONI SEL], [PC MODE], [UPLINK S/S], [UPLINK SW1], [UPLINK SW2], [PLAYLIST], [INHIBIT]  | <ul style="list-style-type: none"> <li>• [SPOT LIGHT] and [BACK LIGHT] functions do not work when the remote control unit (AJ-RC10G) or the extension control unit (AG-EC4G) is connected.</li> <li>• When the dynamic range stretcher function is activated, the digital zoom function is disabled.</li> <li>• The [UPLINK S/S], [UPLINK SW1], and [UPLINK SW2] functions are available when the Upgrade Software Key AG-SFU603G (UPLINK device control function (extra-cost option)) is installed. Items are grayed out and cannot be selected when it is not installed.</li> <li>• The [PLAYLIST] function is available when the Upgrade Software Key AG-SFU604G (Playlist edit function (extra-cost option)) is installed. Items are grayed out and cannot be selected when the board is not mounted.</li> </ul> |  |                 |   |                    |  |  |
| USER1              | Sets the function assigned to the <USER1> button.<br>The setting contents are the same as [USER MAIN].<br>[BACK LIGHT] (page 59)   |  |  |                 |   |                    |  |  |
| USER2              | Sets the function assigned to the <USER2> button.<br>The setting contents are the same as [USER MAIN].<br>[TEXT MEMO] (page 59)  |  |  |                 |   |                    |  |  |
| RET SW             | Sets the function assigned to the <RET> button of lens.<br>[PUSH AF], [D.ZOOMX2], [D.ZOOMX4], [ASSIST], [REC REVIEW], [TEXT MEMO], [SHOT MARK], [INHIBIT]<br>• The function assigned to the <RET> button does not work when [INHIBIT] is selected.   | <ul style="list-style-type: none"> <li>• When an auto-focus compatible lens is not attached, the operation is disabled even if [PUSH AF] is selected.</li> <li>• [RET SW] assigned with the [ASSIST] function operates in the same way as &lt;FOCUS ASSIST&gt; on the camera.</li> </ul>   |  |                 |   |                    |  |  |
| WFM                | <p>Selects the type of waveform to be displayed on the viewfinder screen when the &lt;USER&gt; buttons (&lt;USER MAIN&gt;/&lt;USER1&gt;/&lt;USER2&gt;) to which the waveform monitor function is assigned is pressed.</p> <table border="1" style="width: 100%; border-collapse: collapse;"> <tr> <td style="width: 15%;"><b>[WAVE]</b></td> <td>Displays as a waveform.</td> </tr> <tr> <td><b>[VECTOR]</b></td> <td>Displays as a vector.</td> </tr> <tr> <td><b>[WAVE/VECT]</b></td> <td>Changes display in order of [OFF] → [WAVE] → [VECTOR] → [OFF] each time the button is pressed.</td> </tr> </table>   | <b>[WAVE]</b>  | Displays as a waveform.  | <b>[VECTOR]</b> | Displays as a vector.   | <b>[WAVE/VECT]</b> | Changes display in order of [OFF] → [WAVE] → [VECTOR] → [OFF] each time the button is pressed. |  |
| <b>[WAVE]</b>      | Displays as a waveform.  |  |  |                 |   |                    |  |  |
| <b>[VECTOR]</b>    | Displays as a vector.  |  |  |                 |   |                    |  |  |
| <b>[WAVE/VECT]</b> | Changes display in order of [OFF] → [WAVE] → [VECTOR] → [OFF] each time the button is pressed.   |  |  |                 |   |                    |  |  |
| AUTO KNEE SW       | <p>Selects the function for the &lt;OUTPUT&gt;/&lt;AUTO KNEE&gt; selector switch.</p> <table border="1" style="width: 100%; border-collapse: collapse;"> <tr> <td style="width: 15%;"><b>[DRS]</b></td> <td>Activates the dynamic range stretcher function when the &lt;AUTO KNEE&gt; selector switch is set to &lt;ON&gt;. (page 12)</td> </tr> <tr> <td><b>[ON]</b></td> <td>Activates the auto knee function when the &lt;AUTO KNEE&gt; selector switch is set to &lt;ON&gt;.</td> </tr> <tr> <td><b>[OFF]</b></td> <td>Does not activate the auto knee function when the &lt;AUTO KNEE&gt; selector switch is set to &lt;ON&gt;.</td> </tr> </table> | <b>[DRS]</b>   | Activates the dynamic range stretcher function when the <AUTO KNEE> selector switch is set to <ON>. (page 12)  | <b>[ON]</b>     | Activates the auto knee function when the <AUTO KNEE> selector switch is set to <ON>. | <b>[OFF]</b>       | Does not activate the auto knee function when the <AUTO KNEE> selector switch is set to <ON>.  | <ul style="list-style-type: none"> <li>• When 1080i and progressive mode are set, the dynamic range stretcher function is not activated even if [DRS] is selected, and the auto knee function activated when [ON] is selected operates.</li> <li>• When the dynamic range stretcher function is activated, the digital zoom function is disabled.</li> </ul> |
| <b>[DRS]</b>       | Activates the dynamic range stretcher function when the <AUTO KNEE> selector switch is set to <ON>. (page 12)  |  |  |                 |   |                    |  |  |
| <b>[ON]</b>        | Activates the auto knee function when the <AUTO KNEE> selector switch is set to <ON>.  |  |  |                 |   |                    |  |  |
| <b>[OFF]</b>       | Does not activate the auto knee function when the <AUTO KNEE> selector switch is set to <ON>.  |  |  |                 |   |                    |  |  |
| COLOR BARS         | <p>Set the color bar to be used.</p> <table border="1" style="width: 100%; border-collapse: collapse;"> <tr> <td style="width: 15%;"><b>[AUTO SEL]</b></td> <td>The SMPTE color bar is automatically selected when [SYSTEM MODE] is set to [1080-59.94i], [1080-23.98PsF], [720-59.94P], or [480-59.94i]. The full color bar is automatically selected when [SYSTEM MODE] is set to [1080-50i], [720-50P], or [576-50i].</td> </tr> <tr> <td><b>[SMPTE]</b></td> <td>Displays the SMPTE color bar.</td> </tr> <tr> <td><b>[FULL BARS]</b></td> <td>Displays the full color bar.</td> </tr> </table>  | <b>[AUTO SEL]</b>  | The SMPTE color bar is automatically selected when [SYSTEM MODE] is set to [1080-59.94i], [1080-23.98PsF], [720-59.94P], or [480-59.94i]. The full color bar is automatically selected when [SYSTEM MODE] is set to [1080-50i], [720-50P], or [576-50i]. | <b>[SMPTE]</b>  | Displays the SMPTE color bar.   | <b>[FULL BARS]</b> | Displays the full color bar.   |  |
| <b>[AUTO SEL]</b>  | The SMPTE color bar is automatically selected when [SYSTEM MODE] is set to [1080-59.94i], [1080-23.98PsF], [720-59.94P], or [480-59.94i]. The full color bar is automatically selected when [SYSTEM MODE] is set to [1080-50i], [720-50P], or [576-50i].   |  |  |                 |   |                    |  |  |
| <b>[SMPTE]</b>     | Displays the SMPTE color bar.  |  |  |                 |   |                    |  |  |
| <b>[FULL BARS]</b> | Displays the full color bar.   |  |  |                 |   |                    |  |  |

\_\_\_\_\_ indicates factory setting values.

### [RECORDING SETUP] screen

| Item              | Description of settings  | Remark  |                                     |                   |                          |                   |                          |               |                      |  |
|-------------------|--|---|-------------------------------------|-------------------|--------------------------|-------------------|--------------------------|---------------|----------------------|--|
| REC FUNCTION      | <p>Sets special recording mode. (page 41)</p> <table border="1" style="width: 100%; border-collapse: collapse;"> <tr> <td style="width: 15%;"><b>[NORMAL]</b></td> <td>Does not perform special recording.</td> </tr> <tr> <td><b>[INTERVAL]</b></td> <td>Sets interval recording.</td> </tr> <tr> <td><b>[ONE SHOT]</b></td> <td>Sets one-shot recording.</td> </tr> <tr> <td><b>[LOOP]</b></td> <td>Sets loop recording.</td> </tr> </table> <ul style="list-style-type: none"> <li>• It is always set to [NORMAL] when the power is turned on.</li> </ul> | <b>[NORMAL]</b>   | Does not perform special recording. | <b>[INTERVAL]</b> | Sets interval recording. | <b>[ONE SHOT]</b> | Sets one-shot recording. | <b>[LOOP]</b> | Sets loop recording. | <ul style="list-style-type: none"> <li>• This setting is not available in the following cases: <ul style="list-style-type: none"> <li>- The [REC SIGNAL] item is set to [SDI IN].</li> <li>- Native recording is set with the [REC FORMAT] item.</li> <li>- The [SYSTEM MODE] item is set to [1080-59.94i] or [480-59.94i], and the [CAMERA MODE] item is set to [24P] or [24PA].</li> <li>- Clip connection is underway with one-clip recording.</li> <li>- The [VFR] item is set to [ON].</li> </ul> </li> </ul> |
| <b>[NORMAL]</b>   | Does not perform special recording.  |   |                                     |                   |                          |                   |                          |               |                      |  |
| <b>[INTERVAL]</b> | Sets interval recording.   |   |                                     |                   |                          |                   |                          |               |                      |  |
| <b>[ONE SHOT]</b> | Sets one-shot recording.   |   |                                     |                   |                          |                   |                          |               |                      |  |
| <b>[LOOP]</b>     | Sets loop recording.   |   |                                     |                   |                          |                   |                          |               |                      |  |
| ONE SHOT TIME     | Sets the recording time of one-shot recording. (page 42)<br>[1frm], [2frm], [4frm], [8frm], [16frm], [1s]  | <ul style="list-style-type: none"> <li>• This setting is available only when the [REC FUNCTION] item is set to [ONE SHOT].</li> </ul>               |                                     |                   |                          |                   |                          |               |                      |  |
| INTERVAL TIME     | Sets the interval time for interval recording. (page 41)<br>[2frm], [4frm], [8frm], [16frm], [1s], [2s], [5s], [10s], [30s], [1min], [5min], [10min]   | <ul style="list-style-type: none"> <li>• This setting is available only when the [REC FUNCTION] item is set to [INTERVAL].</li> </ul>               |                                     |                   |                          |                   |                          |               |                      |  |
| START DELAY       | Delays the start of interval recording and one-shot recording approximately one second.<br>[ON], [OFF]   | <ul style="list-style-type: none"> <li>• This setting is available only when the [REC FUNCTION] item is set to [INTERVAL] or [ONE SHOT].</li> </ul> |                                     |                   |                          |                   |                          |               |                      |  |

\_\_\_\_\_ indicates factory setting values.

## Chapter 7 Menu Operations — Menu list

| Item            | Description of settings  | Remark  |
|-----------------|--|---|
| PREREC MODE     | Sets the pre-recording mode. (page 41)<br><b>[ON]</b> , <b>[OFF]</b>   | <ul style="list-style-type: none"> <li>This setting is not available in the following cases: <ul style="list-style-type: none"> <li>The [REC SIGNAL] item is [SDI IN].</li> <li>The [VFR] item is set to [ON].</li> </ul>                     Excluding the case when the frame rate and the number of frames of recording playback are matched (30P:30PN, 25P:25PN, 24P:24PN) <ul style="list-style-type: none"> <li>The [REC FUNCTION] item is set to other than [NORMAL].</li> </ul> </li> </ul>   |
| ONE CLIP REC    | Sets one-clip recording mode. (page 43)<br><b>[ON]</b> , <b>[OFF]</b>  | <ul style="list-style-type: none"> <li>This setting is not available in the following cases: <ul style="list-style-type: none"> <li>The [REC FUNCTION] item is other than [NORMAL].</li> <li>The [REC SIGNAL] item is [SDI IN].</li> <li>The [VFR] item is [ON].</li> </ul>                     Excluding the case when the frame rate and the number of frames of recording playback are matched (30P:30PN, 25P:25PN, 24P:24PN) </li> </ul>  |
| START TEXT MEMO | Sets the function that automatically adds a text memo at recording start position each time recording is started.<br><b>[ON]</b> , <b>[SHOOT INFO]</b> , <b>[OFF]</b>          | <ul style="list-style-type: none"> <li>This setting is not available when the [REC FUNCTION] item is other than [NORMAL].</li> <li>Text memos added when the [START TEXT MEMO] item is [ON] or [SHOOT INFO] indicate the recording start position.</li> </ul> In addition, when [SHOOT INFO] is selected, the camera setting information ([F.RATE]/[SHTR]/[IRIS]/[GAIN]/[ND]/[ZOOM]/[EXT.]/[FOCUS]/[GAMMA]/[CC]) is added to this text memo.<br>To record text memos as character information, refer to "Setting clip metadata" (page 108). |
| TC MODE         | Sets count compensation for the built-in time code generator of the camera. (page 66)<br><b>[DF]</b> Counts in drop frame mode.<br><b>[NDF]</b> Counts in non-drop frame mode. | <ul style="list-style-type: none"> <li>This setting is not available when activating in [24P], [24PA], or [24PN]. Counting is always performed in the non-drop frame mode.</li> </ul>   |
| UB MODE         | Sets the content to be recorded in user bits. (page 64)<br><b>[USER]</b> , <b>[TIME]</b> , <b>[DATE]</b> , <b>[EXT]</b> , <b>[TCG]</b> , <b>[FRM.RATE]</b>                     |   |

\_\_\_\_\_ indicates factory setting values.

### [AUDIO SETUP] screen

| Item            | Description of settings  | Remark   |
|-----------------|--|--|
| FRONT VR CH1    | Sets whether to enable or disable front volume for CH1 input.<br><b>[FRONT]</b> Front volume is enabled when CH1 is front microphone input.<br><b>[W.L.]</b> Front volume is enabled when CH1 is wireless input.<br><b>[REAR]</b> Front volume is enabled when CH1 is rear input.<br><b>[ALL]</b> Front volume is enabled when CH1 is either front, wireless, or rear.<br><b>[OFF]</b> Front volume is disabled for CH1. | <ul style="list-style-type: none"> <li>When audio channel 1 is set to [AUTO] at the [LVL] item on the [AUD02:INPUT] screen of SmartUI, front volume is disabled regardless of the setting of this item since automatic adjustment mode is used.</li> </ul> |
| FRONT VR CH2    | Sets whether to enable or disable front volume for CH2 input. The setting contents are the same as [FRONT VR CH1].<br><b>[OFF]</b>   | <ul style="list-style-type: none"> <li>When audio channel 2 is set to [AUTO] at the [LVL] item on the [AUD02:INPUT] screen of SmartUI, front volume is disabled regardless of the setting of this item since automatic adjustment mode is used.</li> </ul> |
| FRONT VR CH3    | Sets whether to enable or disable front volume for CH3 input. The setting contents are the same as [FRONT VR CH1].<br><b>[OFF]</b>   | <ul style="list-style-type: none"> <li>When audio channel 3 is set to [AUTO] at the [LVL] item on the [AUD02:INPUT] screen of SmartUI, front volume is disabled regardless of the setting of this item since automatic adjustment mode is used.</li> </ul> |
| FRONT VR CH4    | Sets whether to enable or disable front volume for CH4 input. The setting contents are the same as [FRONT VR CH1].<br><b>[OFF]</b>   | <ul style="list-style-type: none"> <li>When audio channel 4 is set to [AUTO] at the [LVL] item on the [AUD02:INPUT] screen of SmartUI, front volume is disabled regardless of the setting of this item since automatic adjustment mode is used.</li> </ul> |
| MIC LOWCUT CH1* | Sets microphone low cut filter for CH1.<br><b>[FRONT]</b> Works for front microphone input.<br><b>[W.L.]</b> Works for wireless input.<br><b>[REAR]</b> Works for rear microphone input.<br><b>[OFF]</b> Off for any input.  |  |
| MIC LOWCUT CH2* | Sets microphone low cut filter for CH2. The setting contents are the same as [MIC LOWCUT CH1].<br><b>[OFF]</b>   |  |
| MIC LOWCUT CH3* | Sets microphone low cut filter for CH3. The setting contents are the same as [MIC LOWCUT CH1].<br><b>[OFF]</b>   |  |

\_\_\_\_\_ indicates factory setting values.

## Chapter 7 Menu Operations — Menu list

| Item            | Description of settings   | Remark  |   |
|-----------------|---|---|---|
| MIC LOWCUT CH4* | Sets microphone low cut filter for CH4.<br>The setting contents are the same as [MIC LOWCUT CH1].<br><b>[OFF]</b> |   |   |
| LIMITER CH1     | Sets CH1 limiter.<br><b>[ON], [OFF]</b>   | <ul style="list-style-type: none"> <li>When audio channel 1 is set to [AUTO] at the [LVL] item on the [AUD02:INPUT] screen of SmartUI, limiter does not work regardless of the setting of this item since automatic adjustment mode is used.</li> </ul>   |   |
| LIMITER CH2     | Sets CH2 limiter.<br><b>[ON], [OFF]</b>   | <ul style="list-style-type: none"> <li>When audio channel 2 is set to [AUTO] at the [LVL] item on the [AUD02:INPUT] screen of SmartUI, limiter does not work regardless of the setting of this item since automatic adjustment mode is used.</li> </ul>   |   |
| LIMITER CH3     | Sets CH3 limiter.<br><b>[ON], [OFF]</b>   | <ul style="list-style-type: none"> <li>When audio channel 3 is set to [AUTO] at the [LVL] item on the [AUD02:INPUT] screen of SmartUI, limiter does not work regardless of the setting of this item since automatic adjustment mode is used.</li> </ul>   |   |
| LIMITER CH4     | Sets CH4 limiter.<br><b>[ON], [OFF]</b>   | <ul style="list-style-type: none"> <li>When audio channel 4 is set to [AUTO] at the [LVL] item on the [AUD02:INPUT] screen of SmartUI, limiter does not work regardless of the setting of this item since automatic adjustment mode is used.</li> </ul>   |   |
| 25M REC CH SEL  | Selects the audio channel to be recorded in DVCPRO and DV formats.  | <ul style="list-style-type: none"> <li>This item is available only when the [SYSTEM MODE] item is [480-59.94i] or [576-50i], and codecs are DVCPRO and DV.</li> <li>Regardless of the number of channels of the input signal to the &lt;SDI OUT/IN (OP)&gt; terminal, the channel set at this item is recorded even if the [REC SIGNAL] item is set to [SDI IN].</li> <li>This setting cannot be changed when clip connection is underway with one-clip recording.</li> </ul> |   |
|                 | <b>[2CH]</b>  |   | Records only CH1 and CH2.   |
|                 | <b>[4CH]</b>  |   | Records all four channels.  |
| TEST TONE       | Selects test signals.   |   |   |
|                 | <b>[NORMAL]</b>   |   | Outputs the test tone to CH1/CH2/CH3/CH4 when the <OUTPUT>/<AUTO KNEE> selector switch is set to <BARS>, and audio channel 1 is set to [FRONT] at the [IN] item on the [AUD02:INPUT] screen of SmartUI.         |
|                 | <b>[ALWAYS]</b>   |   | Always outputs the test tone to CH1/CH2/CH3/CH4 when the <OUTPUT>/<AUTO KNEE> selector switch is set to <BARS>.   |
|                 | <b>[CHSEL]</b>  |   | Outputs the test tone to the channel where the [IN] item on the [AUD02:INPUT] screen of SmartUI is set to [FRONT] when the <OUTPUT>/<AUTO KNEE> selector switch is set to <BARS>. (Does not output to CH3/CH4.) |
|                 | <b>[OFF]</b>  |   | Does not output the test tone.  |
| F.MIC POWER     | Sets the phantom power of front microphone.<br><b>[ON], [OFF]</b>   |   |   |
| F.MIC LEVEL     | Selects the front microphone input level.<br><b>[-40dB], [-50dB], [-60dB]</b>                                     |   |   |
| R.MIC CH1 LEVEL | Selects the rear microphone CH1 input level.<br><b>[-50dB], [-60dB]</b>   |   |   |
| R.MIC CH2 LEVEL | Selects the rear microphone CH2 input level.<br><b>[-50dB], [-60dB]</b>   |   |   |
| HEADROOM        | Sets the headroom (standard level).<br><b>[18dB], [20dB]</b>  | <ul style="list-style-type: none"> <li>The factory settings may differ depending on the region.<br/>(AG-HPX610P: <b>[20dB]</b>, AG-HPX610EJ: <b>[18dB]</b>)</li> </ul>  |   |
| WIRELESS WARN   | Sets whether to issue a warning when the reception status of the wireless receiver is poor.<br><b>[ON], [OFF]</b> |   |   |
| WIRELESS TYPE   | Selects the type of wireless receiver.  | <ul style="list-style-type: none"> <li>If a single channel type wireless receiver is mounted when [DUAL] is selected, no sound is recorded even if CH2 and CH4 are set to [W.L.].</li> </ul>  |   |
|                 | <b>[SINGLE]</b>   |   | Single channel type   |
|                 | <b>[DUAL]</b>   |   | Dual channel type   |

\_\_\_\_\_ indicates factory setting values.

\* Frequency response when the microphone low cut filter is used is between 200 Hz to 10 kHz.

**[IN/OUT SEL] screen**

| Item           | Description of settings   | Remark   |
|----------------|---|--|
| SDI OUT        | Sets the video output from the <SDI OUT/IN (OP)> terminal.  |  |
|                | <b>[ON]</b> Outputs video from the output.  |  |
|                | <b>[OFF]</b> Does not output video from the output.   |  |
| SDI OUT CHAR   | Selects whether to superimpose characters to [SDI OUT].   | <ul style="list-style-type: none"> <li>When the [SYSTEM MODE] item is [1080-23.98PsF], characters are not superimposed to the video of [SDI OUT], and this item is not displayed.</li> </ul>   |
|                | <b>[ON]</b> Superimposes characters.  |  |
|                | <b>[OFF]</b> Does not superimpose characters.   |  |
| SDI METADATA   | Sets superimposition of [SDI OUT] metadata (UMID).  |  |
|                | <b>[ON]</b> Superimposes metadata.  |  |
|                | <b>[OFF]</b> Does not superimpose metadata.   |  |
| SDI EDH        | Sets superimposition of EDH when [SDI OUT] is the SD signal (480i and 576i).  |  |
|                | <b>[ON]</b> Superimposes EDH.   |  |
|                | <b>[OFF]</b> Does not superimpose EDH.  |  |
| HD SDI REMOTE  | Sets whether to use the recording control function for external devices (such as recorders) connected to the <SDI OUT/IN (OP)> terminal or the <MON OUT> terminal. (For HD SDI signal output) | <ul style="list-style-type: none"> <li>The recording control is output to external devices when set the item to [ON]. While recording is being executed, lamps such as the REC lamp, front tally lamp, and back tally lamp on the viewfinder, and the tally lamp on the camera are illuminated.</li> <li>The recording control is not output while interval recording and loop recording.</li> <li>For supported external devices (such as recorders), visit the following website:<br/><a href="http://panasonic.biz/sav/autorec_e/">http://panasonic.biz/sav/autorec_e/</a><br/>The recording control status is displayed on the viewfinder screen of the camera. (page 72)</li> </ul> |
|                | <b>[ON]</b> Controls recording operations of external devices.  |  |
|                | <b>[OFF]</b> Does not control recording operations of external devices.   |  |
| AUTO REC (OP2) | Selects the function that automatically starts or stops recording by detecting REC START/STOP mark from the frame rate information of user bits added to the HD SDI input signal in HD mode.  | <ul style="list-style-type: none"> <li>Set the user bits added to the HD SDI signal at the output device of the HD SDI signal as the frame rate. For setting procedure, refer to the operating instruction of the output device.</li> <li>Set the [REC SIGNAL] item to [SDI IN], and input the HD SDI signal to the &lt;SDI OUT/IN (OP)&gt; terminal.</li> <li>For frame rate information of the user bits, refer to "User bits settings" (page 64).</li> </ul>  |
|                | <b>[TYPE1]</b> Performs automatic recording by detecting from LTC of the HD SDI input signal.   |  |
|                | <b>[TYPE2]</b> Performs automatic recording by detecting from VITC of the HD SDI input signal.  |  |
|                | <b>[OFF]</b> Does not perform automatic recording.  |  |
| MON/HDMI ZEBRA | Selects whether the zebra pattern is superimposed over the output signals from the <MON OUT>, <HDMI>, and <REMOTE> terminals. (The remote VBS signal also interlocks.)                        | <ul style="list-style-type: none"> <li>This setting interlocks with the setting of [ZBR] on the [SET03:MON/HDMI SETUP] screen of SmartUI.</li> </ul>   |
|                | <b>[ON]</b> Superimposes zebra patterns.  |  |
|                | <b>[OFF]</b> Does not superimpose zebra patterns.   |  |
| TC IN/OUT SEL  | Selects whether to use the <TC IN/OUT> terminal in TC IN or TC OUT.   |  |
|                | <b>[TC OUT]</b> Uses TC OUT.  |  |
|                | <b>[TC IN]</b> Uses TC IN.  |  |
| TC OUT         | Sets the time code type output from the <TC IN/OUT> terminal.   |  |
|                | <b>[TCG]</b> Always outputs the time code generator value of the camera.  |  |
|                | <b>[TCG/TCR]</b> Outputs the time code generator value when outputting camera images, and outputs the played time code value when outputting playback images.                                 |  |
| TC VIDEO SYNC  | Sets the output delay of time code output from the <TC IN/OUT> terminal.  |  |
|                | <b>[RECORDING]</b> Outputs TCG to be recorded without delay.  |  |
|                | <b>[VIDEO OUT]</b> Outputs images according to the delay of output images from the <MON OUT> and <SDI OUT/IN (OP)> terminals.   |  |

\_\_\_\_\_ indicates factory setting values.

**[DISPLAY SETUP] screen**

| Item           | Description of settings   | Remark |
|----------------|---|--------|
| EVF PEAK LEVEL | Adjusts the peaking level of the viewfinder screen.                   |        |
|                | <b>[-7] ... [0] ... [+7]</b>  |        |
| EVF PEAK FREQ  | Adjusts the peaking frequency of the viewfinder screen.               |        |
|                | <b>[LOW]</b> Sets the peaking frequency lower.                        |        |
|                | <b>[HIGH]</b> Sets the peaking frequency higher.                      |        |
| EVF TYPE       | Selects the type of viewfinder to be connected.                       |        |
|                | <b>[COLOR]</b> Connects the color viewfinder. (AJ-CVF100G, AG-CVF10G) |        |
|                | <b>[B/W]</b> Connects the black and white viewfinder. (AJ-HVF21KG)    |        |

\_\_\_\_\_ indicates factory setting values.

## Chapter 7 Menu Operations — Menu list

| Item          | Description of settings  | Remark   |
|---------------|--|--|
| EVF COLOR     | Selects whether to display viewfinder images in color or in black and white.   | ● This setting is not available when the [EVF TYPE] item is set to [B/W].  |
|               | [ON] Displays in color.  |  |
|               | [OFF] Displays in black and white.   |  |
| ZEBRA1 DETECT | Sets the level of zebra pattern 1 tilting to the right.<br>[50%] ... [70%] ... [109%]  |  |
| ZEBRA2 DETECT | Sets the level of zebra pattern 2 tilting to the left.<br>[50%] ... [85%] ... [109%]   |  |
| ZEBRA2        | Selects the type of ZEBRA2. (page 80)<br>[ON], [SPOT], [OFF]   |  |
| MARKER        | Sets on/off of the center marker displayed on the viewfinder screen. (page 79)<br>[ON], [OFF]  |  |
| SAFETY ZONE   | Sets the safety zone displayed on the viewfinder screen. (page 79)<br>[90%], [4:3], [13:9], [14:9], [OFF]  | ● When the [SYSTEM MODE] item is set to [480-59.94i] or [576-50i], and the [ASPECT CONV] item is set to [SIDE CROP] and [LETTER BOX], the safety zone is not displayed even when [4:3], [13:9], or [14:9] is selected. |
| FOCUS BAR     | Sets the function to indicate the focus level with bar size.   | ● It is not interlocked with the focus assist button.  |
|               | [ON] Displays the focus bar.   |  |
|               | [OFF] Does not display the focus bar.  |  |
| DATE/TIME     | Sets the date and time display.  |  |
|               | [TIME] Displays hour, minute, and second.  |  |
|               | [DATE] Displays year, month, and day.  |  |
|               | [TIME&DATE] Displays hour, minute, second as well as year, month and day.  |  |
|               | [OFF] Does not display.  |  |
| LEVEL METER   | Sets the audio level meter display.<br>[ON], [OFF]   |  |
| ZOOM/FOCUS    | Selects the unit of zoom and focus values.<br>[NUMBER], [mm/m], [mm/feet], [OFF]<br>● When [mm/m] or [mm/feet] is selected<br>Displayed only when an auto-focus compatible lens is attached. |  |
| AWB C.TEMP    | Used to display the color temperature when white balance is automatically adjusted by setting the <WHITE BAL> switch to either <A> or <B>.   |  |
|               | [ON] Displays the color temperature.   |  |
|               | [OFF] Does not display.  |  |
| CARD/BATT     | Sets the remaining capacity display for P2 card and battery.<br>[ON], [OFF]  |  |
| P2CARD REMAIN | Selects the type of P2 card remaining capacity display for recording.  |  |
|               | [ONE-CARD] Displays the remaining capacity of the card currently being recorded.   |  |
|               | [TOTAL] Displays the total remaining capacity of two cards.  |  |
| OTHER DISPLAY | Sets other information display items.  |  |
|               | [PARTIAL] Displays partial information.  |  |
|               | [ALL] Displays all information.  |  |
|               | [OFF] Does not display.  |  |
| MENU BACK     | Selects whether to make characters stand out by lowering the background transmittance while displaying the setting menu.   |  |
|               | [ON] Lowers the background transmittance.  |  |
|               | [OFF] Does not lower the background transmittance.   |  |
| REC COUNTER   | Sets counter operation during recording.   |  |
|               | [TOTAL] Continues counting by integrating until reset with the <RESET> button.   |  |
|               | [CLIP] Clears the count value when recording starts, and counts time for each shooting.  |  |

\_\_\_\_\_ indicates factory setting values.

### [BATTERY SETUP] screen

| Item          | Description of settings             | Remark |
|---------------|-------------------------------------|--------|
| EXT DC IN SEL | Sets the type of external DC power. |        |
|               | [AC ADAPTER] AC adaptor             |        |
|               | [BATTERY] Battery                   |        |

\_\_\_\_\_ indicates factory setting values.



Chapter 7 Menu Operations — Menu list

| Item            | Description of settings   | Remark  |
|-----------------|---|---|
| BATTERY SELECT  | Sets the battery type.<br>[HYTRON50], [HYTRON140], [DIONIC HC], [DIONIC90], [DIONIC160], [ENDURA7], [ENDURA10], [PAG L96e], [TYPE A], [TYPE B], [BAT STAT]  | <ul style="list-style-type: none"> <li>When using a battery whose charge level is detected using a percentage, near end and end operation is conducted according to the percentage of the charge level if [BAT STAT] is selected.</li> <li>Set a near end percentage for [BAT STAT NEAR], or an end percentage for [BAT STAT END] depending on the battery used.</li> <li>When the battery charge level percentage cannot be detected, it will follow the setting value of [TYPE A] even if it is set to [BAT STAT]. Make sure that the setting values [TYPE A FULL] (fully charged), [TYPE A NEAR] (near end), or [TYPE A END] (end) is appropriate for the battery being used.</li> </ul> |
| BATTERY MODE    | Sets the near end.  |   |
|                 | [AUTO]      Near end is set automatically with the battery selected with [BATTERY SELECT].  |   |
|                 | [MANUAL]      Sets the near end voltage manually.   |   |
| HYTRON50 NEAR   | Sets the near end voltage of [HYTRON50]. (Can be adjusted in 0.1 V units.)<br>[11.0V] ... [13.4V] ... [15.0V]   |   |
| HYTRON140 NEAR  | Sets the near end voltage of [HYTRON140]. (Can be adjusted in 0.1 V units.)<br>[11.0V] ... [13.1V] ... [15.0V]  |   |
| DIONIC HC NEAR  | Sets the near end voltage of [DIONIC HC]. (Can be adjusted in 0.1 V units.)<br>[11.0V] ... [13.1V] ... [15.0V]  |   |
| DIONIC90 NEAR   | Sets the near end voltage of [DIONIC90]. (Can be adjusted in 0.1 V units.)<br>[11.0V] ... [13.5V] ... [15.0V]   |   |
| DIONIC160 NEAR  | Sets the near end voltage of [DIONIC160]. (Can be adjusted in 0.1 V units.)<br>[11.0V] ... [13.4V] ... [15.0V]  |   |
| ENDURA7 NEAR    | Sets the near end voltage of [ENDURA7]. (Can be adjusted in 0.1 V units.)<br>[11.0V] ... [13.4V] ... [15.0V]  |   |
| ENDURA10 NEAR   | Sets the near end voltage of [ENDURA10]. (Can be adjusted in 0.1 V units.)<br>[11.0V] ... [13.4V] ... [15.0V]   |   |
| PAG L96e NEAR   | Sets the near end voltage of [PAG L96e]. (Can be adjusted in 0.1 V units.)<br>[11.0V] ... [13.1V] ... [15.0V]   |   |
| TYPE A FULL     | Sets the full voltage of [TYPE A]. (Can be adjusted in 0.1 V units.)<br>[12.0V] ... [15.5V] ... [17.0V]   |   |
| TYPE A NEAR     | Sets the near end voltage of [TYPE A]. (Can be adjusted in 0.1 V units.)<br>[11.0V] ... [13.0V] ... [15.0V]   |   |
| TYPE A END      | Sets the end voltage of [TYPE A]. (Can be adjusted in 0.1 V units.)<br>[11.0V] ... [12.7V] ... [15.0V]  |   |
| TYPE B FULL     | Sets the full voltage of [TYPE B]. (Can be adjusted in 0.1 V units.)<br>[12.0V] ... [15.6V] ... [17.0V]   |   |
| TYPE B NEAR     | Sets the near end voltage of [TYPE B]. (Can be adjusted in 0.1 V units.)<br>[11.0V] ... [13.4V] ... [15.0V]   |   |
| TYPE B END      | Sets the end voltage of [TYPE B]. (Can be adjusted in 0.1 V units.)<br>[11.0V] ... [12.9V] ... [15.0V]  |   |
| BAT STAT NEAR   | Sets the near end percentage of [BAT STAT].<br>[4%], [5%] - [10%] (by units of [1%]), [12%] - [20%] (by units of [2%])  | <ul style="list-style-type: none"> <li>When the battery charge level percentage cannot be detected, this will follow the near end voltage value set in [TYPE A].</li> <li>When the battery charge level percentage cannot be detected, this will follow the near end voltage value set in [TYPE A].</li> </ul>  |
| BAT STAT END    | Sets the end percentage of [BAT STAT END].<br>[1%] - [10%] (by units of [1%])   | <ul style="list-style-type: none"> <li>When the battery charge level percentage cannot be detected, this will follow the end voltage value set in [TYPE A].</li> <li>When using a battery which displays battery charge level by units of 10%, end is determined only in two stages: when it is set to [1%] to [5%], or when it is set to [6%] to [10%].</li> </ul>   |
| NEAR END CANCEL | Sets the cancelation of battery near end warning.<br>[ON], [OFF]<br><ul style="list-style-type: none"> <li>When this item is set to [ON], flashing of the warning lamp and tally lamp can be stopped by pushing the &lt;DISP/MODE CHK&gt; switch towards the &lt;CHK&gt; side.</li> </ul> |   |

\_\_\_\_\_ indicates factory setting values.

**[CARD FUNCTIONS] screen**

- Operations on setting data files may result in error during playback or when the [PC MODE] item on the setting menu [PC/USB/LAN] screen is set to [ON]. Set the [PC MODE] item to [OFF] before performing operations.

| Item           | Description of settings  | Remark  |
|----------------|--|---|
| SCENE FILE     | Reads and writes scene files from or in an SD memory card.   | <ul style="list-style-type: none"> <li>This setting is not available when clip connection is underway with one-clip recording.</li> </ul> |
|                | [FILE SELECT] Selects a scene file (1 to 4).   |   |
|                | [READ] Selects and reads the setting value of a scene file (1 to 4) saved in the SD memory card.     |   |
|                | [WRITE] Saves the setting value of the current scene file (1 to 4) in the SD memory card.            |   |
|                | [TITLE RELOAD] Updates the title list.   |   |
| USER FILE      | Reads and writes user files (all setting items other than scene files) from or in an SD memory card. | <ul style="list-style-type: none"> <li>This setting is not available when clip connection is underway with one-clip recording.</li> </ul> |
|                | [FILE SELECT] Selects a user file (1 to 4).  |   |
|                | [READ] Selects and reads the setting value of a user file (1 to 4) saved in the SD memory card.      |   |
|                | [WRITE] Saves the setting value of the current user file (1 to 4) in the SD memory card.             |   |
|                | [TITLE RELOAD] Updates the title list.   |   |
| SD CARD FORMAT | Formats an SD memory card.   | <ul style="list-style-type: none"> <li>This setting is not available when clip connection is underway with one-clip recording.</li> </ul> |

**[LENS SETUP] screen**

| Item            | Description of settings   | Remark  |
|-----------------|---|---|
| SHADING SELECT  | Sets the parameter for shading compensation.  |   |
|                 | [USER1] User setting 1  |   |
|                 | [USER2] User setting 2  |   |
|                 | [USER3] User setting 3  |   |
|                 | [OFF] Shading compensation off  |   |
| SHADING (USER)  | Sets the shading parameter for [USER1], [USER2], and [USER3] of [SHADING SELECT].   | <ul style="list-style-type: none"> <li>This setting is not available when the [SHADING SELECT] item is [OFF].</li> </ul>  |
| CAC             | Sets whether to activate the lens chromatic aberration correction (CAC) function.   |   |
|                 | [ON] Activates when the chromatic aberration correction function activation is possible.  |   |
|                 | [OFF] Does not activate the chromatic aberration correction function.   |   |
| CAC PROPERTY    | Displays the chromatic aberration correction file number currently in use, and the information of the chromatic aberration correction files already read on the camera. |   |
| CAC CARD READ   | Reads the chromatic aberration correction file from the SD memory card.   | <ul style="list-style-type: none"> <li>This setting is not available when clip connection is underway with one-clip recording.</li> </ul>                       |
| CAC FILE DELETE | Displays the list of chromatic aberration correction files read on the camera, and deletes the selected files among them.   |   |
| CAC FILE INIT   | Initializes the chromatic aberration correction files read on the camera to the chromatic aberration correction files of the factory setting.                           |   |
| IRIS GAIN       | Sets whether the iris correction control is performed on the camera or the lens when an auto-focus lens is attached.  | <ul style="list-style-type: none"> <li>When an auto-focus compatible lens is not attached, the selected item is displayed in blue and cannot be set.</li> </ul> |
|                 | [CAMERA] Performs the iris correction control on the camera.  |   |
|                 | [LENS] Performs the iris correction control on the lens.  |   |
| IRIS GAIN VALUE | Sets the adjustment value for the [IRIS GAIN] item. This setting is enabled when the [IRIS GAIN] item is set to [CAMERA].<br>[1], [2], [3]                              | <ul style="list-style-type: none"> <li>When an auto-focus compatible lens is not attached, the selected item is displayed in blue and cannot be set.</li> </ul> |
| IRIS ADJUST     | Force sets iris.<br>[F2.8], [F16]   |   |
| FB ADJUST       | Adjusts the lens flange back.   | <ul style="list-style-type: none"> <li>This can be adjusted when an auto-focus compatible lens is attached.</li> </ul>  |

\_\_\_\_\_ indicates factory setting values.

**[PROXY SETTING] screen**

Available when the video encoder board (extra-cost option) is mounted. Items are grayed out and cannot be selected when the board is not mounted.

| Item                        | Description of settings   | Remark  |
|-----------------------------|---|---|
| REC MEDIA (OP1)             | Selects media for recording proxy data.   |   |
|                             | [P2]  | Records the proxy data to the P2 card.  |
|                             | [P2&SD]   | Records proxy data in both the P2 card and SD memory card.  |
|                             | [OFF]   | Does not record proxy data.   |
| REC MODE (1080) (OP1)       | Sets the proxy data recording mode when the 1080 mode is selected.<br>[STD 2CH MP4], [SHQ 2CH MOV], [HQ 4CH MOV], [HQ 2CH MOV], [LOW 2CH MOV] | <ul style="list-style-type: none"> <li>This setting is not available in the following cases:           <ul style="list-style-type: none"> <li>- Clip connection is underway with one-clip recording.</li> <li>- The [REC FUNCTION] item is set to other than [NORMAL].</li> <li>- The [VFR] item is set to [ON].</li> </ul> </li> <li>Excluding the case when the frame rate and the number of frames of recording playback are matched (30P:30PN, 25P:25PN, 24P:24PN)</li> </ul> |
| REC MODE (720) (OP1)        | Sets the proxy data recording mode when the 720P mode is selected.<br>[STD 2CH MP4], [SHQ 2CH MOV], [HQ 4CH MOV], [HQ 2CH MOV], [LOW 2CH MOV] | <ul style="list-style-type: none"> <li>This setting is not available when clip connection is underway with one-clip recording.</li> </ul>   |
| REC MODE (SD) (OP1)         | Sets the proxy data recording mode only when SD mode is selected.<br>[STD 2CH MP4], [LOW 2CH MOV]   | <ul style="list-style-type: none"> <li>This setting is not available when clip connection is underway with one-clip recording.</li> </ul>   |
| TC SUPER (OP3)              | Sets superimposition of time code display on proxy data recorded images.  |   |
|                             | [UPPER]   | Superimposes time code on the upper area of recorded images.  |
|                             | [LOWER]   | Superimposes time code on the lower area of recorded images.  |
|                             | [OFF]   | Does not superimpose time code on recorded images.  |
| STREAMING MODE (OP1), (OP3) | Selects the proxy streaming function.   |   |
|                             | [INHIBIT]   | Stops the proxy streaming function.   |
|                             | [RTP]   | Selects the RTP method.   |
|                             | [HTTP]  | Selects the HTTP live streaming method.   |
| PROXY DISP (OP1)            | Sets whether to display a message when proxy recording starts.  |   |
|                             | [ON]  | Displays a message.   |
|                             | [OFF]   | Does not display a message.   |

\_\_\_ indicates factory setting values.

**[PC/USB/LAN] screen**

| Item          | Description of settings   | Remark   |
|---------------|---|--|
| PC MODE SEL   | Sets the operation mode of the camera when the [PC MODE] item is set to [ON], and external devices (such as a hard disk drive and a computer) are connected with USB 2.0. |  |
|               | [USB HOST]  | Selects the mode when using a hard disk drive by connecting to the camera with USB 2.0.  |
|               | [USB DEVICE]  | Selects the mode when connecting the camera to a computer with USB 2.0, and using the P2 card as a mass storage. (page 146)  |
| PC MODE       | Operates the camera in the mode selected at the [PC MODE SEL] item.   |  |
|               | [ON]  | Operates in [PC MODE].   |
|               | [OFF]   | Stops [PC MODE] and returns to normal operation.   |
|               | <ul style="list-style-type: none"> <li>It is always set to [OFF] when the power is turned on.</li> </ul>  |  |
| UPLINK DEVICE | Sets whether to allow or prohibit the uplink device mode.   |  |
|               | [ON]  | Allows communication with an UPLINK device.  |
|               | [OFF]   | Prohibits communication with an UPLINK device.   |
|               |   | <ul style="list-style-type: none"> <li>The display becomes blue and settings cannot be performed when the [PC MODE] item is set to [ON], or when the [P2 BROWSE] item is not set to [OFF].</li> <li>When OP5 is not mounted, items are grayed out and settings cannot be performed.</li> </ul> |

\_\_\_ indicates factory setting values.

## Chapter 7 Menu Operations — Menu list

| Item              | Description of settings   | Remark   |
|-------------------|---|--|
| NETWORK SEL (OP3) | Sets the connection method when making network connection between external devices (such as a computer) and the camera.   | <ul style="list-style-type: none"> <li>• If [PC MODE] is set to [ON] when OP3 is installed, the selected item is displayed in blue and cannot be set.</li> </ul>   |
|                   | <b>[WLAN]</b> Connects with wireless LAN.   |  |
|                   | <b>[LAN]</b> Connects with the <LAN> terminal.  |  |
| P2 BROWSE (OP3)   | Sets the P2 browsing function.  | <ul style="list-style-type: none"> <li>• If [PC MODE] is set to [ON] when OP3 is installed, the selected item is displayed in blue and cannot be set.</li> </ul>   |
|                   | <b>[ON]</b> Activates the P2 browsing function.   |  |
|                   | <b>[ON (+CTRL)]</b> Activates the P2 browsing function, and accepts recording control of the camera as well as settings of time code and user bits from the connected device. |  |
|                   | <b>[OFF]</b> Deactivates the P2 browsing function.  |  |
| PLAYLIST (OP6)    | Sets the playlist edit function.  | <ul style="list-style-type: none"> <li>• If [PC MODE] item is set to [ON], the selected item is displayed in blue and cannot be set.</li> <li>• When OP6 is not mounted, items are grayed out and settings cannot be performed.</li> </ul> |
|                   | <b>[ON]</b> Activates the playlist edit function.   |  |
|                   | <b>[OFF]</b> Stops the playlist edit function.  |  |

\_\_\_\_\_ indicates factory setting values.

### [OTHER FUNCTIONS] screen

| Item          | Description of settings  | Remark  |
|---------------|--|---|
| USER FILE     | Saves, reads, or initializes user files in the built-in memory of the camera. (page 82)<br><b>[LOAD]</b> , <b>[SAVE]</b> , <b>[INITIAL]</b><br>• This setting does not affect the items set on the [SCENE FILE] screen.                          | <ul style="list-style-type: none"> <li>• This setting is not available in the following cases: <ul style="list-style-type: none"> <li>- The USB device mode is set.</li> <li>- Clip connection is underway with one-clip recording.</li> </ul> </li> <li>• User file includes the setting value of SmartUI.</li> </ul>  |
| ACCESS LED    | Sets whether to light the access LED of the P2 card.<br><b>[ON]</b> , <b>[OFF]</b>   |   |
| REC TALLY     | Sets the tally lamp display on the viewfinder.   | <ul style="list-style-type: none"> <li>• When the [HD SDI REMOTE] item is set to [ON] and the recording operation control signal is output superimposing to the HD SDI signal, the front tally lamp on the viewfinder and the back and rear tally lamps on the body are illuminated, regardless of the setting of this item or recording status of the camera.</li> </ul> |
|               | <b>[RED]</b> Illuminates the red tally lamp on the viewfinder during recording with the camera. The front tally lamp and the back and rear tally lamps on the body are illuminated.  |   |
|               | <b>[GREEN]</b> Illuminates the green tally lamp on the viewfinder during recording with the camera. The front tally lamp or the tally lamps on the body are not illuminated  |   |
|               | <b>[CHAR]</b> During recording with the camera, the tally lamp on the viewfinder is not illuminated and the recording status is displayed only with text on the screen. The front tally lamp or the tally lamps on the body are not illuminated. |   |
|               | • The screen display for recording always appears regardless of the above settings.  |   |
| CLOCK SETTING | Sets the built-in calendar (date and time).<br>For details, refer to "Setting the date/time of the internal clock" (page 31).  |   |
| TIME ZONE     | Sets the time lag against the Greenwich Mean Time (GMT).<br><b>[-12:00] ... [0:00] ... [+13:00]</b><br>For details, refer to "Setting the date/time of the internal clock" (page 31).  | <ul style="list-style-type: none"> <li>• This setting is not initialized when initialization is performed with the [INITIAL] item of [MENU INIT] and [USER FILE].</li> </ul>  |
| GL PHASE      | Selects the output signal of which phase is to be locked to the signal input to the <GENLOCK IN> terminal when in the HD (1080i, 720P) mode. (page 69)   | <ul style="list-style-type: none"> <li>• This setting is not available when the [SYSTEM MODE] item is set to [480-59.94i], [576-50i], and [1080-23.98PsF].</li> </ul>   |
|               | <b>[HD SDI]</b> Locks the phase of HD SDI output signals.  |   |
|               | <b>[COMPOSITE]</b> Locks the phase of the down-converted composite signal.   |   |
| H PHASE       | Adjusts the horizontal phase when locking the phase to the signal to the signal input to the <GENLOCK IN> terminal.<br><b>[-512] ... [0] ... [+511]</b>  | <ul style="list-style-type: none"> <li>• Press and turn up or down the jog dial button, and keep pressing it at the position to change the value faster.</li> </ul>   |
| SEEK SELECT   | Selects the position to be cued when the <FF/▶▶> or <◀◀/REW> button is pressed while playback is paused.   |   |
|               | <b>[CLIP]</b> Top of the clip  |   |
|               | <b>[CLIP&amp;T]</b> Top of the clip and text memo location   |   |
| MENU INIT     | Initializes all the setting menus including all scene files F1 to F6 and user files (including settings of SmartUI) to the factory settings.   | <ul style="list-style-type: none"> <li>• This setting is not available in the following cases: <ul style="list-style-type: none"> <li>- The USB device mode is set.</li> <li>- Clip connection is underway with one-clip recording.</li> </ul> </li> </ul>  |

\_\_\_\_\_ indicates factory setting values.

**[DIAGNOSTIC] screen**

| Item          | Description of settings   | Remark  |
|---------------|---|---|
| VERSION       | Displays the version of all firmware in the camera.<br>The version of each firmware can be checked by opening a sub-screen.<br>(Sub-screen)                   |   |
|               | <b>[CAM SOFT]</b>   | Camera microcomputer software                           |
|               | <b>[SYSCON SOFT]</b>  | System control microcomputer software                   |
|               | <b>[P2CS BL2-1]</b>   | P2 control microcomputer boot program 1                 |
|               | <b>[P2CS BL2-2]</b>   | P2 control microcomputer boot program 2                 |
|               | <b>[P2CS KR]</b>  | P2 control microcomputer kernel                         |
|               | <b>[P2CS AP]</b>  | P2 control microcomputer application software           |
|               | <b>[VUP]</b>  | System software for updating all firmware of the camera |
|               | <b>[VUP FS]</b>   | File system for updating the camera                     |
|               | <b>[CAM FPGA]</b>   | Camera FPGA configuration ROM                           |
|               | <b>[BE FPGA]</b>  | BE FPGA configuration ROM                               |
|               | <b>[PROXY SOFT]</b>   | Proxy board software version display (OP1)              |
|               | <b>[PROXY FPGA]</b>   | Proxy board FPGA configuration ROM (OP1)                |
| OPTION STATUS | Indicates whether there is an optional board, and displays activated status of the upgrade software key. The following items are displayed on the sub-screen. |   |
|               | <b>[SDI IN BOARD]</b>   | --- (with board: [ACTIVE], without board: ---)          |
|               | <b>[PROXY BOARD]</b>  | --- (with board: [ACTIVE], without board: ---)          |
|               | <b>[PRODUCTION PACK]</b>  | Activate: [ACTIVE]<br>No: [---]                         |
|               | <b>[NETWORK FUNC.]</b>  | Activate: [ACTIVE]<br>No: [---]                         |
|               | <b>[UPLINK DEVICE]</b>  | Activate: [ACTIVE]<br>No: [---]                         |
|               | <b>[PLAYLIST]</b>   | Activate: [ACTIVE]<br>No: [---]                         |
| MODEL NAME    | Displays the product name of the camera.  |   |
| SERIAL NO.    | Displays the serial number of the camera.   |   |
| OPERATION     | Displays the operation time of the camera.  |   |

## Chapter 8 **Using SmartUI**

---

A new interface consisting of an LCD display and multiple switches. It enables scene file setting, audio input/output setting, time code setting and so on.

## Setting menu basic operations

### SmartUI basic operations

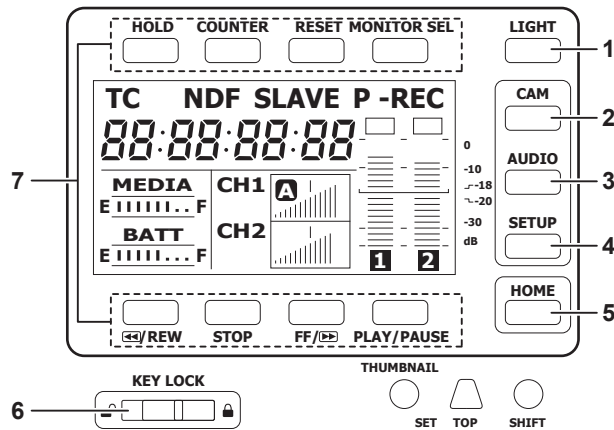

When the camera is turned on, the [HOME] screen is displayed. The status of the [HOME] screen at previous start-up is retained.

#### 1 <LIGHT> button

Toggles the backlight of SmartUI on and off. Can be operated regardless of the status of the <KEY LOCK> switch.

#### 2 <CAM> button

Displays a settings screen related to the camera image.

Each time you press the button, the settings screens change in order.

#### 3 <AUDIO> button

Displays a settings screen related to audio.

Each time you press the button, the settings screens change in order.

#### 4 <SETUP> button

Displays a settings screen related to time code and image output.

Each time you press the button, the settings screens change in order.

#### 5 <HOME> button

- While another screen is displayed, press this button to return to the [HOME] screen.

- While the [HOME] screen is displayed, press this button to change the status information display at the bottom of the screen.

- While the <SHIFT> button is pressed, press the <HOME> button to display the information of clips selected on the thumbnail screen.

#### 6 <KEY LOCK> switch

Slide to the right to lock the operations of all buttons of SmartUI. Slide to the left to unlock.

\* Buttons for thumbnail operations will be locked as well.

#### 7 <HOLD> button, <COUNTER> button, <RESET> button, <MONITOR SEL> button, <<</REW> button, <STOP> button, <FF/> button, and <PLAY/PAUSE> button

- When the [HOME] screen is displayed

The function printed above or below each button is performed.

- When the setting screen is displayed by pressing the <CAM> button, <AUDIO> button, or <SETUP> button on the [HOME] screen

Instead of the printed functions, the functions in the [ ] of SmartUI are assigned to upper or lower buttons corresponding to each setting screen. For details, refer to "Menu list" (page 138).

### Initializing SmartUI setting menu items

Items configured with SmartUI are saved in the user file.

By selecting [INITIAL] in the [USER FILE] item of the [OTHER FUNCTIONS] screen, you can restore the user file menu setting to its factory setting.

Use the [MENU INIT] item in the [OTHER FUNCTIONS] screen to restore all of the user files and six scene files to their factory settings.

## Setting menu structure

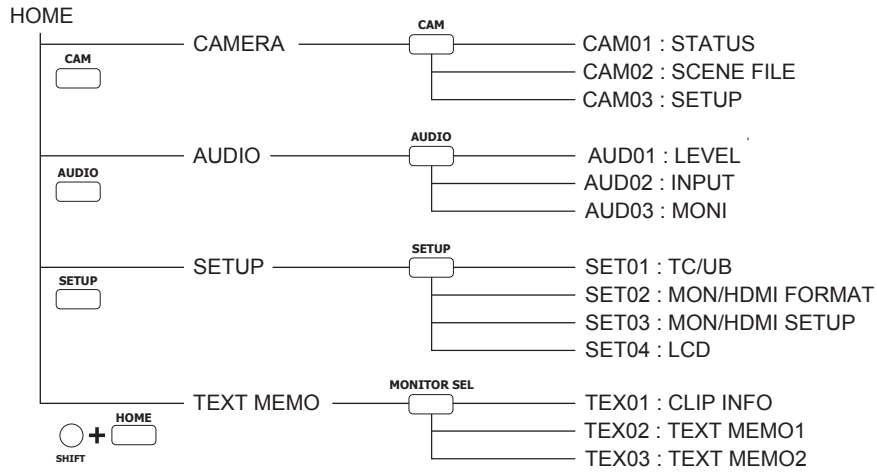



# SmartUI menu operation overview

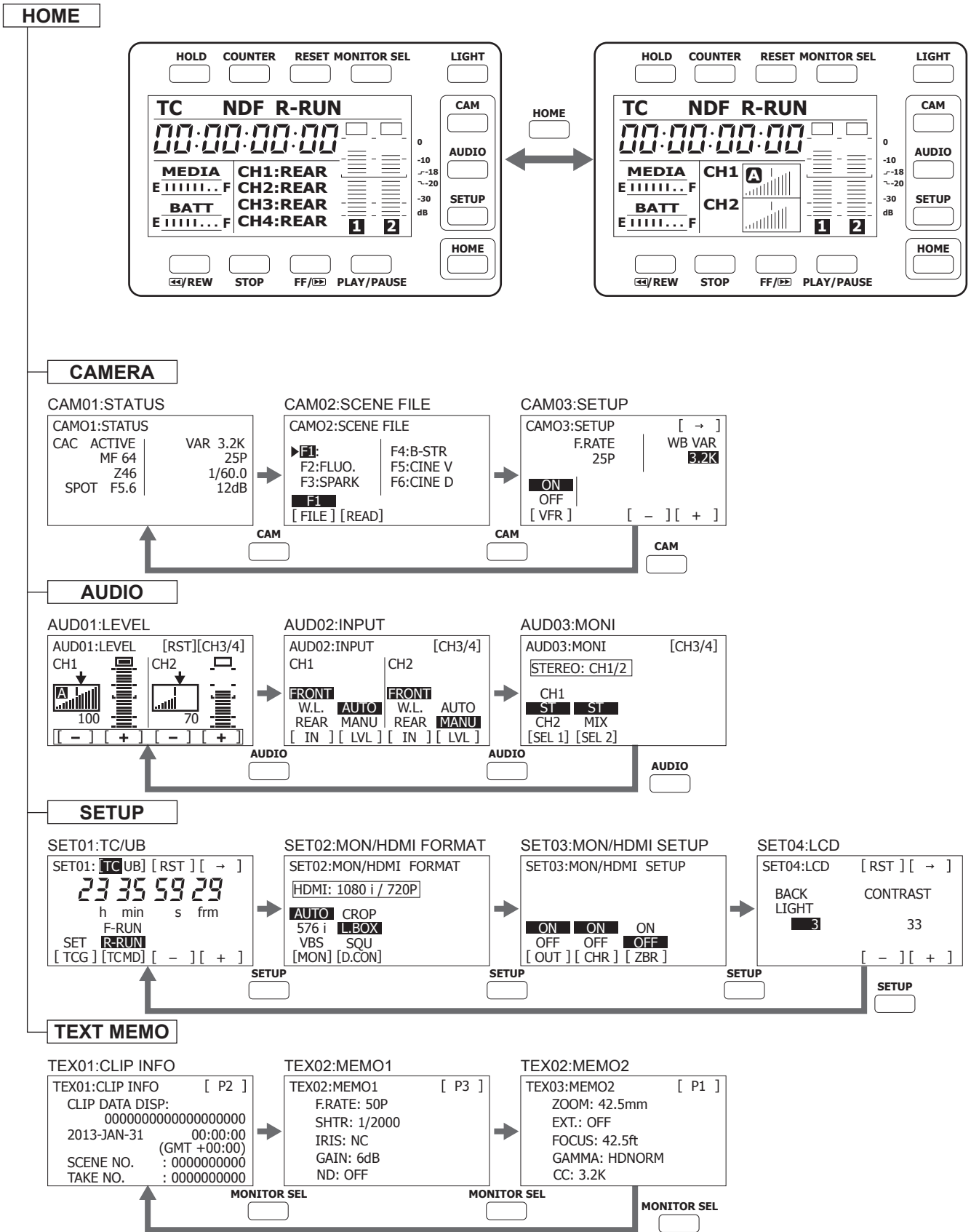

## Menu list

### [CAMERA] screen

| Screen           | Corresponding button                      | Setting details and setting value |   |  |
|------------------|---|-----------------------------------|---|--|
| CAM01:STATUS     | Displays the camera image related status. |                                   |   |  |
|                  |   |                                   |   |  |
|                  | —   | 1                                 | Displays whether the chromatic aberration compensation function is activated. | <b>[CAC ACTIVE]</b> , <b>[CAC---</b><br>Displayed only when the lens that supports the chromatic aberration compensation function is attached.   |
|                  | —   | 2                                 | Displays the focus control information.                                       | <b>[MF**]</b> , <b>[AF**]</b><br>Displayed only when an auto-focus compatible lens is attached.<br>Any number between [99] and [00] is displayed in the place of **. When the distance to the in-focus subject becomes shorter, the value decreases. (page 74) |
|                  | —   | 3                                 | Displays the zoom position.   | <b>[Z00]</b> - <b>[Z99]</b> , <b>[Z***mm]</b>  |
|                  | —   | 4                                 | Displays the auto iris settings and the iris F value.                         | <b>[BACK]</b> , <b>[SPOT]</b> , <b>[F*.*]</b> , <b>[OPEN]</b> , <b>[CLOSE]</b> , <b>[NC]</b>   |
|                  | —   | 5                                 | Displays the white balance control mode and the color temperature.            | <b>[ATW]</b> , <b>[ATW LOCK]</b> , <b>[Ach]</b> , <b>[Bch]</b> , <b>[P3.2K]</b> , <b>[P5.6K]</b> , <b>[VAR*.*K]</b>  |
|                  | —   | 6                                 | Displays the frame rate.  | <b>[**P]</b> , <b>[24PA]</b> , <b>[60i (50i)]</b> , <b>[**:**PN]</b> , <b>[**:60i (50i)]</b>   |
|                  | —   | 7                                 | Displays the shutter value.   | <b>[1/****]</b> , <b>[***.*d]</b>  |
| —                | 8   | Displays the gain status.         | <b>[-3dB]</b> to <b>[18dB]</b>  |  |
| CAM02:SCENE FILE | Switches the scene files.                 |                                   |   |  |
|                  | <◀◀/REW> button                           | <b>[FILE]</b>                     | Selects the number to switch the scene files.                                 | <b>[F1]</b> to <b>[F6]</b>   |
|                  | <STOP> button                             | <b>[READ]</b>                     | Changes the operation according to the selected scene file.                   |  |

— indicates factory setting values.

## Chapter 8 Using SmartUI — Menu list

| Screen      | Corresponding button   | Setting details and setting value  |  |
|-------------|--|--|--|
| CAM03:SETUP | Configures the white balance variable value and variable frame rate (VFR). |  |  |
|             | <◀◀/REW> button  | <b>[VFR] (OP4)</b><br>Toggles the variable frame rate on/off. <ul style="list-style-type: none"> <li>• This setting is not available when the setting menu on the viewfinder screen is open.</li> <li>• Other conditions where the setting is not available are same as the setting menu [VFR] item on the viewfinder screen.</li> <li>• During recording, operation is not changed even if the setting is changed. The setting is applied after recording is completed (and after clip connection is completed in one clip recording).</li> </ul> | <b>[ON], [OFF]</b>   |
|             | <FF/▶▶> button   | <b>[-]</b><br>Decreases the setting value of the selected item.  |  |
|             | <PLAY/PAUSE> button  | <b>[+]</b><br>Increases the setting value of the selected item.  |  |
|             | <MONITOR SEL> button   | <b>[-&gt;]</b><br>Moves the item selection to the right. When the item selection moves to the right edge, it moves back to the left edge.  | <b>[F.RATE] (OP4)</b><br>Sets the variable frame rate. <ul style="list-style-type: none"> <li>• This setting is not available when the setting menu on the viewfinder screen is open.</li> <li>• Other conditions where the setting is not available are same as the setting menu [FRAME RATE] item on the viewfinder screen.</li> <li>• During recording, operation is not changed even if the setting is changed. The setting is applied after recording is completed (and after clip connection is completed in one clip recording).</li> </ul> |
|             |  | <b>[WB VAR]</b><br>Specifies the color temperature for the variable function where any color temperature can be specified.   | <b>[2.4K] to [3.2K] to [9.9K]</b>  |

\_\_\_\_\_ indicates factory setting values.

**[AUDIO] screen**

| Screen      | Corresponding button   | Setting details and setting value  |
|-------------|--|--|
| AUD01:LEVEL | Configures the audio levels for audio channel 1/2 and audio channel 3/4. |  |
|             | <b>■ When audio channel 1/2 is selected</b>                              |  |
|             | <◀◀/REW> button  | <b>[-]</b><br>Decreases the audio volume value of audio channel 1.   |
|             | <STOP> button  | <b>[+]</b><br>Decreases the audio volume value of audio channel 1.   |
|             | <FF/▶▶> button   | <b>[-]</b><br>Decreases the audio volume value of audio channel 2.   |
|             | <PLAY/PAUSE> button  | <b>[+]</b><br>Decreases the audio volume value of audio channel 2.   |
|             | <RESET> button   | <b>[RST]</b><br>Resets the audio volume of audio channel 1/2 to the user-preset value.<br>Press this button for three seconds to save the current audio volume values of audio channel 1/2 as the user-preset values. The user-preset position is indicated as the down arrow ↓ on the audio volume display. |
|             | <MONITOR SEL> button   | <b>[CH3/4]</b><br>Toggles the audio volume setting screen between audio channel 3 and 4.<br>This operation also switches the audio channels output to the speaker, earphone, and <AUDIO OUT> terminal. The display channels for audio level meter and audio volume on the [HOME] screen also switch.         |
|             | <b>■ When audio channel 3/4 is selected</b>                              |  |
|             | <◀◀/REW> button  | <b>[-]</b><br>Decreases the audio volume value of audio channel 3.   |
|             | <STOP> button  | <b>[+]</b><br>Decreases the audio volume value of audio channel 3.   |
|             | <FF/▶▶> button   | <b>[-]</b><br>Decreases the audio volume value of audio channel 4.   |
|             | <PLAY/PAUSE> button  | <b>[+]</b><br>Decreases the audio volume value of audio channel 4.   |
|             | <RESET> button   | <b>[RST]</b><br>Resets the audio volume of audio channel 3/4 to the user-preset value.<br>Press this button for three seconds to save the current audio volume values of audio channel 3/4 as the user-preset values. The user-preset position is indicated as the down arrow ↓ on the audio volume display. |
|             | <MONITOR SEL> button   | <b>[CH1/2]</b><br>Toggles the audio volume setting screen between audio channel 1 and 2.<br>This operation also switches the audio channels output to the speaker, earphone, and <AUDIO OUT> terminal. The display channels for audio level meter and audio volume on the [HOME] screen also switch.         |

\_\_\_\_\_ indicates factory setting values.

## Chapter 8 Using SmartUI — Menu list

| Screen                                      | Corresponding button   | Setting details and setting value  |   |
|---|--|--|---|
| AUD02:INPUT                                 | Selects the audio input signal and sets the recording adjustment method. |  |   |
|   | <b>■ When audio channel 1/2 is selected</b>                              |  |   |
|   | <◀◀/REW> button  | <b>[IN]</b><br>Selects the input signal to be recorded to audio channel 1.   | <b>[FRONT]</b><br>Records the microphone input signal connected to the <MIC IN> terminal.<br><b>[W.L.]</b><br>Records the input signal from the wireless receiver.<br><b>[REAR]</b><br>Records the audio input signal from the audio device or microphone connected to the <AUDIO IN> terminal. |
|   | <STOP> button  | <b>[LVL]</b><br>Selects the method to adjust the recording level for audio channel 1.  | <b>[AUTO]</b><br>Enables automatic adjustment.<br><b>[MANU]</b><br>Enables manual adjustment. The setting contents are the same as [AUD01:LEVEL].   |
|   | <FF/▶▶> button   | <b>[IN]</b><br>Selects the input signal to be recorded to audio channel 2.   | The setting contents are the same as audio channel 1.   |
|   | <PLAY/PAUSE> button  | <b>[LVL]</b><br>Selects the method to adjust the recording level for audio channel 2.  | The setting contents are the same as audio channel 1.   |
|   | <MONITOR SEL> button   | <b>[CH3/4]</b><br>Toggles the audio input setting screen between CH3/CH4. Setting contents that switch in coordination are the same as the [AUD01:LEVEL] screen.   |   |
|   | <b>■ When audio channel 3/4 is selected</b>                              |  |   |
|   | <◀◀/REW> button  | <b>[IN]</b><br>Selects the input signal to be recorded to audio channel 3.   | The setting contents are the same as audio channel 1.   |
|   | <STOP> button  | <b>[LVL]</b><br>Selects the method to adjust the recording level for audio channel 3.  | The setting contents are the same as audio channel 1.   |
|   | <FF/▶▶> button   | <b>[IN]</b><br>Selects the input signal to be recorded to audio channel 4.   | The setting contents are the same as audio channel 1.   |
|   | <PLAY/PAUSE> button  | <b>[LVL]</b><br>Selects the method to adjust the recording level for audio channel 4.  | The setting contents are the same as audio channel 1.   |
|   | <MONITOR SEL> button   | <b>[CH1/2]</b><br>Toggles the audio input setting screen between CH1/CH2. Setting contents that switch in coordination are the same as the [AUD01:LEVEL] screen.   |   |
|   | AUD03:MONI   | Selects the audio to be output to the speaker, the <PHONES> terminal, and the <AUDIO OUT> terminal.  |   |
| <b>■ When audio channel 1/2 is selected</b> |  |  |   |
| <◀◀/REW> button                             |  | <b>[SEL1]</b><br>Selects the audio to be output to the speaker, the <PHONES> terminal, and the <AUDIO OUT> terminal.   | <b>[CH1]</b><br>Monaural output from audio channel 1.<br><b>[ST]</b><br>Stereo output from audio channel 1 and 2.<br><b>[CH2]</b><br>Monaural output from audio channel 2.  |
| <STOP> button                               |  | <b>[SEL2]</b><br>Selects the audio to be output from the speaker, the <PHONES> terminal, and the <AUDIO OUT> terminal when [ST] is selected at [SEL1].             | <b>[ST]</b><br>Stereo output from audio channel 1 and 2.<br><b>[MIX]</b><br>Mixed output from audio channel 1 and 2.  |
| <MONITOR SEL> button                        |  | <b>[CH3/4]</b><br>Toggles the audio monitor setting screen between CH3/CH4. Setting contents that switch in coordination are the same as the [AUD01:LEVEL] screen. |   |
| <b>■ When audio channel 3/4 is selected</b> |  |  |   |
| <◀◀/REW> button                             |  | <b>[SEL1]</b><br>Selects the audio to be output to the speaker, the <PHONES> terminal, and the <AUDIO OUT> terminal.   | <b>[CH3]</b><br>Monaural output from audio channel 3.<br><b>[ST]</b><br>Stereo output from audio channel 3 and 4.<br><b>[CH4]</b><br>Monaural output from audio channel 4.  |
| <STOP> button                               |  | <b>[SEL2]</b><br>Selects the audio to be output from the speaker, the <PHONES> terminal, and the <AUDIO OUT> terminal when [ST] is selected at [SEL1].             | <b>[ST]</b><br>Stereo output from audio channel 3 and 4.<br><b>[MIX]</b><br>Mixed output from audio channel 3 and 4.  |
| <MONITOR SEL> button                        |  | <b>[CH1/2]</b><br>Toggles the audio monitor setting screen between CH1/CH2. Setting contents that switch in coordination are the same as the [AUD01:LEVEL] screen. |   |

\_\_\_\_\_ indicates factory setting values.

[SETUP] screen

| Screen      | Corresponding button | Setting details and setting value  |
|-------------|----------------------|--|
| SET01:TC/UB |                      | <p>Sets the time code or user bits.</p> <p>When an item other than [UB] is selected for the counter display on the [HOME] screen, the time code setting screen appears, and when [UB] is selected on the [HOME] screen, the user bits setting screen appears.</p> <p>■ <b>Time code settings screen:</b></p> <ul style="list-style-type: none"> <li>• To set the time code, press the &lt;◀◀/REW&gt; button to change to the time code setting mode.</li> <li>• The setting values of each digit of the time code are from [0] to [9] (decimal).</li> </ul>  |
|             | <◀◀/REW> button      | <p><b>[TCG]</b><br/>Starts and exits the time code setting mode.</p> <ul style="list-style-type: none"> <li>• The time code setting is applied when the setting mode exits.</li> </ul> <p>When the &lt;◀◀/REW&gt; button is pressed, [SET] is displayed in black and white inversion, and the time code setting mode is set. When the &lt;◀◀/REW&gt; button is pressed again, [SET] returns to the normal display, and the time code setting mode exits.</p>   |
|             | <STOP> button        | <p><b>[TC_MD]</b><br/>Selects the advance setting mode for the built-in time code generator.</p> <p><b>[F-RUN]</b><br/>Use this function to advance the time code continuously, regardless of the P2 card recording operation. Set to this position to, for example, set the time code to the current time or externally lock the time code.</p> <p><b>[R-RUN]</b><br/>Use this function to advance the time code only during recording. A time code recorded normally will be continuously recorded.</p> <ul style="list-style-type: none"> <li>• If a clip is deleted, or if the frame rate is set to [24P]/[24PA] and the recording continues to a frame other than [24P]/[24PA], continuous recording may fail.</li> </ul> |
|             | <FF/▶▶> button       | <p><b>[-]</b><br/>Decreases the setting value of the selected digit in the time code.</p>  |
|             | <PLAY/PAUSE> button  | <p><b>[+]</b><br/>Increases the setting value of the selected digit in the time code.</p>  |
|             | <COUNTER> button     | <p><b>[TC/UB]</b><br/>Switches to the user bits setting screen.</p>  |
|             | <RESET> button       | <p><b>[RST]</b><br/>Resets all time code setting values to 0.</p>  |
|             | <MONITOR SEL> button | <p><b>[→]</b><br/>Moves the selected digit in the time code to the right. When the selected digit moves to the right edge, it moves back to the left edge.</p>   |
|             |                      | <p>■ <b>User bits settings screen:</b></p> <ul style="list-style-type: none"> <li>• To set the user bits, press the &lt;◀◀/REW&gt; button to change to the user bits setting mode.</li> <li>• The setting values of each digit of the user bits are from [0] to [F] (hexadecimal).</li> </ul>  |
|             | <◀◀/REW> button      | <p><b>[UBG]</b><br/>Starts and exists the user bits setting mode.</p> <ul style="list-style-type: none"> <li>• The user bits setting is applied when the setting mode exits.</li> </ul> <p>When the &lt;◀◀/REW&gt; button is pressed, [SET] is displayed in black and white inversion, and the user bits setting mode is set. When the &lt;◀◀/REW&gt; button is pressed again, [SET] returns to the normal display, and the user bits setting mode exits.</p>  |
|             | <STOP> button        | <p><b>[TC_MD]</b><br/>Switches to the advance setting mode for the built-in time code generator. The setting contents are the same as when [TCG] is selected.</p>  |
|             | <FF/▶▶> button       | <p><b>[-]</b><br/>Decreases the setting value of the selected digit in the user bits.</p>  |
|             | <PLAY/PAUSE> button  | <p><b>[+]</b><br/>Increases the setting value of the selected digit in the user bits.</p>  |
|             | <COUNTER>            | <p><b>[TC/UB]</b><br/>Switches to the user bits setting screen.</p>  |
|             | <RESET> button       | <p><b>[RST]</b><br/>Resets all user bits setting values to 0.</p>  |
|             | <MONITOR SEL> button | <p><b>[→]</b><br/>Moves to the right of the selected digit in the user bits. When the selected digit moves to the right edge, it moves back to the left edge.</p>  |

\_\_\_\_\_ indicates factory setting values.

## Chapter 8 Using SmartUI — Menu list

| Screen                   | Corresponding button   | Setting details and setting value   |   |
|--------------------------|--|---|---|
| SET02:MON/HDMI<br>FORMAT | <◀◀/REW> button  | <b>[MON]</b><br>Sets the signal format type output from the <MON OUT> terminal.<br>With this setting, the signal format to be out put from the <HDMI> terminal is also switched.  | <b>[AUTO] (HDMI:[1080i/720P])</b><br>Displayed only in the HD mode.<br>The SDI signal is output according to the setting of the [SYSTEM MODE] item on the setting menu [SYSTEM SETUP] screen. <ul style="list-style-type: none"> <li>• The 1080i or 720P signal is also output from the &lt;HDMI&gt; terminal according to the [SYSTEM MODE] item setting.</li> <li>• For [1080-23.98PsF], the signal pulled down to 1080/59.94i is output from both &lt;MON OUT&gt; and &lt;HDMI&gt; terminals.</li> </ul> |
|                          |  | <b>[480i] or [576i] (HDMI:[480P] or [576P])</b><br>Displayed only in the HD mode.<br>The SDI signal of 480i or 576i is output. <ul style="list-style-type: none"> <li>• The 480P or 576P signal is output from the &lt;HDMI&gt; terminal.</li> </ul>  | <b>[SDI] (HDMI:[480P] or [576P])</b><br>Displayed only in the SD mode.<br>According to the setting of the [SYSTEM MODE] item on the setting menu [SYSTEM SETUP] screen, the SDI signal of 480i or 576i. <ul style="list-style-type: none"> <li>• The 480P or 576P signal is output from the &lt;HDMI&gt; terminal.</li> </ul>   |
|                          | <STOP> button  | <b>[D.CON]</b><br>Sets the aspect for the down-conversion output signal in the HD mode. This item is not displayed in the SD mode.  | <b>[CROP]</b><br>Side-crop mode (Crops the left and right edges.)   |
|                          |  |   | <b>[L.BOX]</b><br>Letterbox mode (Adds black bands at the top and bottom of the image.)   |
|                          |  |   | <b>[SQU]</b><br>Squeeze mode (Squeezes images horizontally.)  |
| SET03:MON/HDMI<br>SETUP  | <◀◀/REW> button  | <b>[OUT]</b><br>Enables or disables the output from the <MON OUT> terminal.   | <b>[ON], [OFF]</b>  |
|                          | <STOP> button  | <b>[CHR]</b><br>Specifies whether characters are superimposed over the output from <MON OUT>, <HDMI>, and <REMOTE> terminals.<br><br>This setting is disabled when a remote control unit (AG-EC4G) is connected, and the settings on the remote control unit or extension control unit supersede. | <b>[ON], [OFF]</b>  |
|                          | <FF/▶▶> button   | <b>[ZBR]</b><br>Specifies whether the zebra pattern is superimposed over the output from <MON OUT>, <HDMI>, and <REMOTE> terminals. <ul style="list-style-type: none"> <li>• This setting is not available when the setting menu on the viewfinder screen is open.</li> </ul>                     | <b>[ON], [OFF]</b>  |
| SET04:LCD                | <FF/▶▶> button   | <b>[-]</b><br>Decreases the setting value of the selected item. Press and hold this button to continuously decrease the setting value.  |   |
|                          | <PLAY/PAUSE> button  | <b>[+]</b><br>Increases the setting value of the selected item. Press and hold this button to continuously decrease the setting value.  |   |
|                          | <RESET> button   | <b>[RST]</b><br>Resets the setting value of the selected item to its factory setting value.   |   |
|                          | <MONITOR SEL> button   | <b>[→]</b><br>Moves the item selection to the right. When the item selection moves to the right edge, it moves back to the left edge.   |   |
|                          |  | <b>[BACK LIGHT]</b><br>Sets the luminance of SmartUI.   | <b>[1] ... [3] ... [5]</b>  |
|                          | <b>[CONTRAST]</b><br>Sets the contrast of SmartUI. <ul style="list-style-type: none"> <li>• The SmartUI screen may be hidden depending on the setting value.<br/>                     In such a case, press the &lt;HOME&gt; to return to the [HOME] screen and hold down the &lt;LIGHT&gt; and &lt;RESET&gt; buttons. The setting value of [CONTRAST] is reset to the factory setting.</li> </ul> | <b>[0] ... [33] ... [63]</b>  |   |

\_\_\_\_\_ indicates factory setting values.

[TEXT MEMO] screen

| Screen          | Corresponding button   | Setting details and setting value  |   |   |
|-----------------|--|------------------------------------|---|---|
| TEX01:CLIP INFO | Displays the information of the clip selected on the thumbnail.  |                                    |   |   |
|                 | <div style="border: 1px solid black; padding: 5px; width: fit-content; margin: 0 auto;">                     TEX01:CLIP INFO [ P2 ]<br/>                     CLIP DATA DISP:<br/>                     00000000000000000000 — 1<br/>                     2013-JAN-31 00:00:00 — 2<br/>                     (GMT +00:00)<br/>                     SCENE NO. : 0000000000 — 3<br/>                     TAKE NO. : 0000000000 — 4                 </div> |                                    |   |   |
|                 | —  | 1                                  | Displays the contents on the clip.                              | Refer to [DATE FORMAT] in "Setting the thumbnail display" (page 111). |
|                 | —  | 2                                  | Displays the date and time when the selected clip was recorded. |   |
|                 | —  | 3                                  | Displays the SCENE NO. of the clip.                             |   |
| —               | 4  | Displays the TAKE NO. of the clip. |   |   |
| TEX02:MEMO1     | Displays the [START TEXT MEMO] information of the clip selected on the thumbnail.  |                                    |   |   |
| TEX03:MEMO2     |  |                                    |   |   |



## Chapter 9 **Connecting to External Devices**

---

## Connection through the <USB2.0> terminal

### USB connection to a computer in the device mode

By connecting the camera to a computer via USB 2.0, the P2 card inserted in the camera can be used as mass storage.

#### Connecting to a computer

##### 1 Connect the USB cable to the <USB2.0> terminal (device).

###### NOTE

- The USB 2.0 cable is not supplied with the camera. Prepare a commercial USB 2.0 cable (double-shielded for noise suppression).
- A USB connection cable of up to 5 m is supported, however, a cable of 3 m or shorter is recommended as preferable.

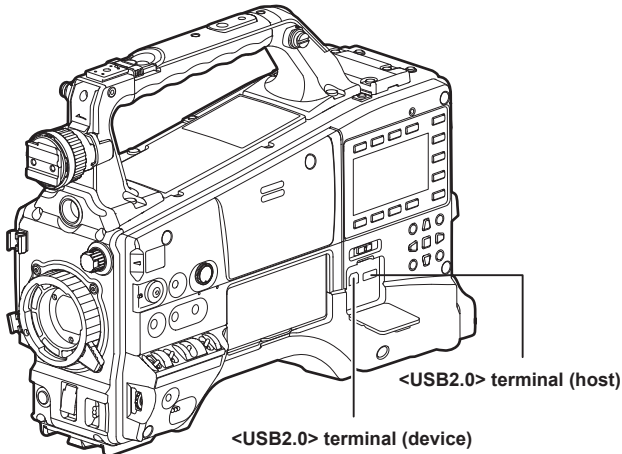

##### 2 Set the [PC MODE SEL] item on the setting menu [PC/USB/LAN] screen to [USB DEVICE], and set the [PC MODE] item to [ON].

For details, refer to “Setting menu basic operations” (page 116).

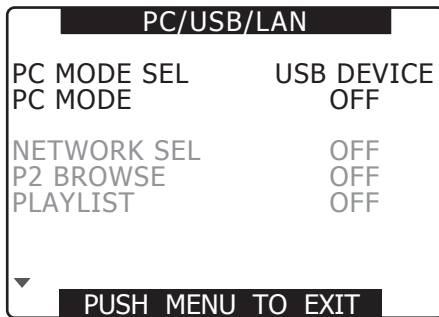

###### NOTE

- The [PC MODE] can be assigned to the <USER> buttons (<USER MAIN>/<USER1>/<USER2>) at the [USER MAIN], [USER1], and [USER2] items on the setting menu [SW MODE] screen respectively. However, when the menu is open, pressing the <USER> buttons (<USER MAIN>/<USER1>/<USER2>) does not activate the function.

- Before connecting the camera using the USB cable, install P2 Viewer Plus to a computer.
- Download the USB driver from the website and install it onto a computer. For installation procedure of the driver, refer to the installation manual on the website. For the latest information on the driver, visit the following website.  
<http://pro-av.panasonic.net/>
- The camera supports only USB 2.0. Ensure your computer supports USB 2.0.
- When connecting the camera to a computer via USB, ensure that no other device is connected to the computer via USB.
- When connecting the camera via USB, do not eject the P2 card.
- When USB is connected, the P2 card access LED turns off when not accessed.
- When the camera is operating in the USB device mode, no recording/playback operation or clip thumbnail operation is allowed.
- When the camera is operating in the USB device mode, the P2 card remaining capacity and status are not displayed. Audio is not output from the <MON OUT> terminal. The audio level meter is not displayed on the viewfinder and the monitor connected to the camera.

During USB connection, [USB DEVICE CONNECTED] is displayed at the center of the viewfinder screen and status area of the [HOME] screen of SmartUI. If not connected properly, [USB DEVICE DISCONNECTED] is displayed.



##### 3 Exit the USB device mode.

There are three ways to do so:

- Turn the <POWER> switch of the camera to <OFF>.
- Switch the [PC MODE] item on the setting menu [PC/USB/LAN] screen to [OFF].
- Press the <USER> buttons (<USER MAIN>/<USER1>/<USER2>) to which [PC MODE] is assigned.

###### NOTE

- When the [PC MODE SEL] item of the [PC/USB/LAN] screen on the setting menu is set to [USB DEVICE], switching the [PC MODE] item from [ON] to [OFF] restarts the camera. (It takes approximately five seconds.)

### USB host mode

Connect a hard disk drive (HDD) that supports USB 2.0 to the camera to save the card data, view the saved clips in thumbnail, and write back to the P2 card.

#### Switching to the USB host mode

##### 1 Set the [PC MODE SEL] item on the setting menu [PC/USB/LAN] screen to [USB HOST], and set the [PC MODE] item to [ON].

For details, refer to “Setting menu basic operations” (page 116).

- The camera enters the USB host mode.

- During USB host mode, [USB HOST CONNECTED] is displayed at the center of the viewfinder screen and status area of the [HOME] screen of SmartUI. If the hard disk drive is not connected properly, [USB HOST DISCONNECTED] is displayed.

- The USB host mode and normal mode can be switched by pressing the <USER> buttons (<USER MAIN>/<USER1>/<USER2>) to which [PC MODE] is assigned if the function is assigned to the <USER> buttons (<USER MAIN>/<USER1>/<USER2>). However, if the thumbnail screen is displayed, pressing the <USER> buttons (<USER MAIN>/<USER1>/<USER2>) does not switch the mode. For details, refer to “Assigning functions to <USER> buttons” (page 59).

**2 Press the <THUMBNAIL> button.**

- The thumbnail screen is displayed.
- Ensure that [USB HOST] is displayed at the bottom-right of the screen.
- If a hard disk drive is connected, the HDD mark on the top-right turns on. However, a red mark indicates that the hard disk drive contents cannot be copied. Check the type of the hard disk drive. For details on HDD mark, refer to “Slot number, hard disk drive status” (page 102).

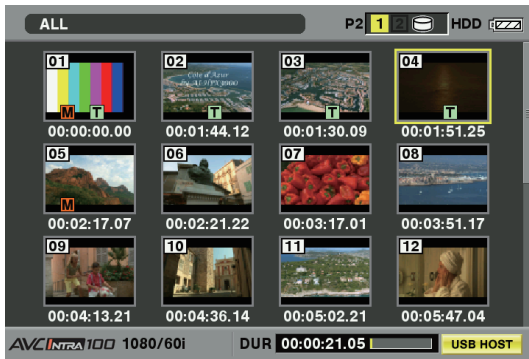

**NOTE**

- In the USB host mode, you can play the P2 card contents, but cannot record the camera image or external output. The clips written to the hard disk drive must be written back to the P2 card for playback. For details, refer to “Writing back to the P2 card” (page 149).

**3 Exit the USB host mode.**

There are three ways to do so:

- Turn the <POWER> switch of the camera to <OFF>.
  - With the thumbnail screen closed, switch the [PC MODE] item on the setting menu [PC/USB/LAN] screen to [OFF].
  - Press the <USER> buttons (<USER MAIN>/<USER1>/<USER2>) to which [PC MODE] is assigned.\*
- \* If the thumbnail screen is displayed, pressing the <USER> buttons (<USER MAIN>/<USER1>/<USER2>) does not exit the USB host mode.

**Using the USB host mode**

Hard disk drives that can be used:

- Hard disk drives that support USB 2.0 connection
- Storage unit that has Panasonic USB 2.0 interface
- For details on the compatible unit, visit the support desk at the following website: <http://pro-av.panasonic.net/>

**NOTE**

- A hard disk drive cannot be connected to the <USB2.0> terminal (sub-host) (page 25).
- Although the camera supports the USB bus power (5 V, 0.5 A), some hard disk drives may not be bootable. In such a case, supply power to the hard disk drive in another way.
- While connecting a hard disk drive to the camera, use the fully charged or external DC power supply to avoid problems in copying or formatting operations.
- Even if the hard disk drives are turned off, do not connect multiple hard disks using a hub. Also, do not connect any other devices other than a hard disk drive using a hub when a hard disk drive is connected.
- Hard disk drives over 2 TB (2048 GB) are not supported.

**Viewing hard disk drive information**

Information about the hard disk drive connected via USB can be viewed by the following methods:

**1 Switch to the USB host mode.**

For details, refer to “Switching to the USB host mode” (page 146).

**2 Connect the hard disk drive via USB.**

**3 Press the <THUMBNAIL> button to display the thumbnail screen.**

**4 Press the <THUMBNAIL MENU> button and select [HDD] → [EXPLORE] from the thumbnail menu.**

The screen switches to the hard disk drive information display screen.

For [TYPE S] or [P2STORE]

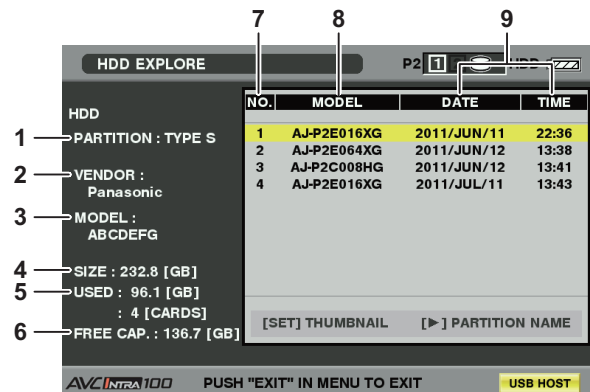

Press the <SET> button to switch the screen.



Press the <EXIT> button to return to the previous screen.

For [FAT]

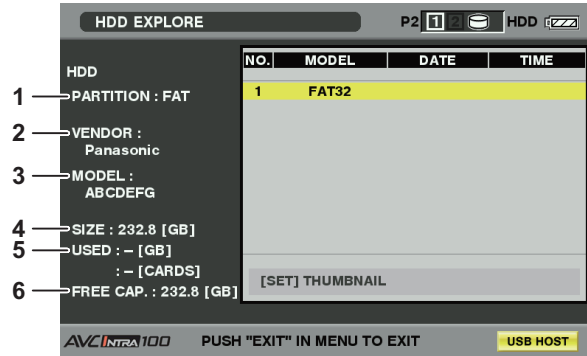

Press the <SET> button to switch the screen.



Press the <EXIT> button to return to the previous screen.

1 [PARTITION]

The hard disk drive type is displayed. The available functions differ depending on the hard disk drive type.

| Hard disk drive type | Features  | Available functions  |
|----------------------|---|--|
| [TYPE S]             | A special format to enable fast write/write-back on a card basis. Perform [FORMAT] on the camera to obtain this format.   | Thumbnail display, write/write back on a card basis, write-back on a clip basis, format                                      |
| [P2STORE]            | Indicates P2 STORE. No writing operation is allowed.  | Thumbnail display, write back on a card basis, write back on a clip basis  |
| [FAT]                | A hard disk drive that the heading basic partition is FAT16 or FAT32 in a computer and that requires the CONTENTS directory in the partition root.                    | Thumbnail display, write back on a clip basis, format<br>• After formatting, it can be used as the [TYPE S] hard disk drive. |
| [OTHER]              | Hard disk drive other than the above.<br>• Displayed when the root does not have the CONTENTS directory, or when the file system is not FAT16 or FAT32, such as NTFS. | format<br>• After formatting, it can be used as the [TYPE S] hard disk drive.  |

- 2 [VENDOR]  
The vendor name of the hard disk drive is displayed.
- 3 [MODEL]  
The model name of the hard disk drive is displayed.
- 4 [SIZE]  
The total space of the hard disk drive is displayed.
- 5 [USED]  
The usage capacity of the hard disk drive is displayed at the upper section. (Unit: GB)  
The number of P2 cards saved on the hard disk drive is displayed at the bottom section.
- 6 [FREE CAP.]  
The free space in the hard disk drive (GB) is displayed.
- 7 Partition number  
The partition number of the hard disk drive is displayed. The partition number is on a single P2 card basis.

**NOTE**

- Up to ten numbers are displayed in the screen. If there are more than 11 partitions, use the cursor buttons (▽) to scroll down.
- Up to 23 P2 cards can be recorded to the hard disk drive.

8 [MODEL]

The model name of the P2 card on the recording source is displayed.

**NOTE**

- Press the cursor buttons (▷) to switch to [PARTITION NAME]. Use the cursor buttons (◀) to return to the model name display.

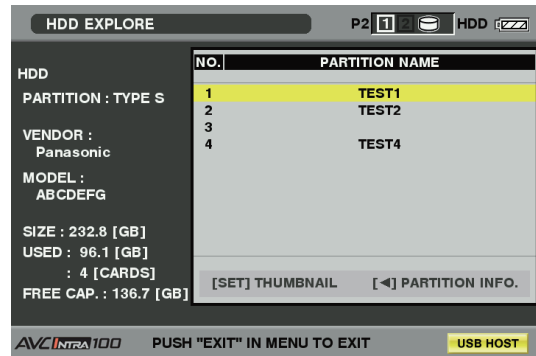

9 [DATE]/[TIME]

Date and time when the data in the partition is saved.

10 [SERIAL]

The serial number of the P2 card on the recording source is displayed.

11 [VERIFY]

The setting and result of verification are displayed.

|               |  |
|---------------|--|
| [ON/FINISHED] | Verification was performed and the verification result matches.        |
| [ON/FAILED]   | Verification was performed but the verification result does not match. |
| [OFF]         | Verification was not performed.  |
| [----]        | No verification information available.                                 |

**NOTE**

- Clips after the 1001st clip are not displayed even if the hard disk drive type is FAT.
- For the FAT formatted hard disk drives, only the information in the initial partition is displayed.
- If there is an invalid partition in P2 STORE (AJ-PCS060G), the partition information is displayed in gray.

12 [NAME]

[PARTITION NAME] is displayed. A [PARTITION NAME] can be entered from the software keyboard by selecting [CHANGE PARTITION NAME] in the [OPERATION] menu while the thumbnails are displayed. (Up to 20 characters)

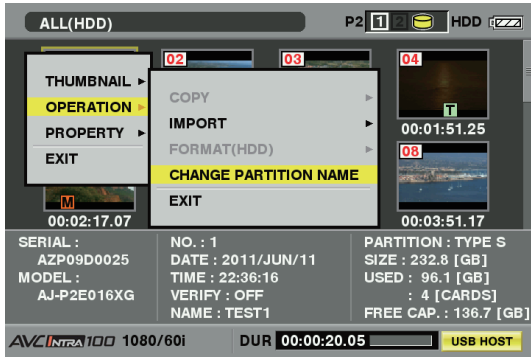

### Formatting the hard disk drive

- 1 Switch to the USB host mode.**  
For details, refer to “Switching to the USB host mode” (page 146).
- 2 Connect the hard disk drive via USB.**
- 3 Press the <THUMBNAIL> button to display the thumbnail screen.**
- 4 Press the <THUMBNAIL MENU> button and select [HDD] → [EXPLORE] from the thumbnail menu.**  
The screen switches to the hard disk drive information display screen.
- 5 Select [OPERATION] → [FORMAT (HDD)] from the menu, and use the cursor buttons and the <SET> button to select [YES].**

- A confirmation message is displayed again. Select [YES] to format the hard disk drive.
- After formatting, it can be used as the [TYPE S] hard disk drive.

#### NOTE

- After formatting the hard disk drive, all contents of the hard disk drive are deleted. You cannot partially format the hard disk to keep some partitions.
- The hard disk drive formatted with the camera is rewritten with a computer, the operation with the camera and data on the hard disk drive are not guaranteed afterwards.
- Data deleted as a result of formatting cannot be restored. Always check data before formatting.

### Writing to the hard disk drive

- 1 Switch to the USB host mode.**  
For details, refer to “Switching to the USB host mode” (page 146).
- 2 Connect the hard disk drive via USB.**  
If the hard disk drive is not formatted with the camera, refer to “Formatting the hard disk drive” (page 149) to format the hard disk drive.
- 3 Insert the P2 card.**
- 4 Press the <THUMBNAIL> button to display the thumbnail screen.**
- 5 Press the <THUMBNAIL MENU> button, and select [HDD] → [EXPORT] from the thumbnail menu to specify the slot of the P2 card which contains data to write to the hard disk drive.**

### **6 Select [YES].**

- Writing starts.
- A progress bar is displayed during a write operation. To cancel writing, press the <SET> button and select [YES] for the cancel confirmation.
- [COPY COMPLETED!] is displayed when writing completes.

#### NOTE

- To bypass verification at writing, select [HDD] → [SETUP] from the thumbnail menu, and set [VERIFY] to [OFF]. The time until writing completes shortens, but no data writing verification is performed.
- Select [ALL SLOT] to write the contents of all the P2 cards inserted in the camera in bulk to the hard disk.

#### NOTE

- If the type of the hard disk drive is [TYPE S], writing is available only on a card basis. Up to 23 P2 cards can be saved to the hard disk drive. Each set of data in the P2 cards saved in the hard disk drive is recognized as a separate drive in a computer.
- If you want to write a P2 card containing a defective clip to a hard disk drive, we recommend that you fix the defective clip.
- If you cancel the process during verification, writing from that P2 card to the hard disk drive is already completed.

### Writing back to the P2 card

You can select clips from the hard disk drive to write back to the card.

- 1 Switch to the USB host mode.**  
For details, refer to “Switching to the USB host mode” (page 146).
- 2 Connect the hard disk drive via USB.**
- 3 Insert the P2 card to which you want to write back the clips into the slot.**
- 4 Press the <THUMBNAIL MENU> button, and select [HDD] → [EXPLORE] from the thumbnail menu to navigate to the partition containing the data to read, and then select the partition using the <SET> button.**
- 5 Select the clip in the thumbnail to write back to the P2 card from the hard disk drive.**

### **6 Press the <THUMBNAIL MENU> button, and select [OPERATION] → [COPY] from the thumbnail menu, and then select the slot of the P2 card to be written back.**

### **7 Select [YES].**

- Writing back to the P2 card starts.
- [COPY COMPLETED!] is displayed when writing back completes.

#### NOTE

- No verification is performed when you select a clip to write.

**Writing back to the P2 card when the hard disk drive type is [TYPE S] or [P2STORE]**

You can write back on a card basis. Format the P2 card to be written back in advance.

**1 Switch to the USB host mode.**

For details, refer to “Switching to the USB host mode” (page 146).

**2 Connect the hard disk drive via USB.****3 Insert the P2 card to which you want to write back the clips into the slot.****4 Press the <THUMBNAIL MENU> button, and select [HDD] → [EXPLORE] from the thumbnail menu to navigate to the partition containing the data to read, and then select the partition using the <SET> button.****5 Select [OPERATION] → [IMPORT] from the thumbnail menu, and select the slot where the empty P2 card is installed.****6 Select [YES].**

Writing to the card starts.

- [COPY COMPLETED!] is displayed when writing back completes.

**NOTE**

- You cannot perform an import operation to P2 cards of different models on a partition basis. Import on a clip basis.
- To bypass verification at writing back, select [HDD] → [SETUP] from the thumbnail menu, and set [VERIFY] to [OFF]. The time until writing back completes shortens, but no data writing back verification is performed.
- If you write back a clip to a P2 card other than the P2 card to which that clip was originally saved, the clip written back may be an incomplete clip. In that case, merge the clips. For details, refer to “Reconnecting incomplete clips” (page 107).

**Notes when using a hard disk drive**

- Use the hard disk drive (including [P2STORE]) in the following conditions.
  - Use the hard disk drive within its operational range (such as temperature).
  - Do not place the hard disk drive in a location that is unstable or subject to vibration.
- Some hard disk drives may not function properly.
- A hard disk drive with the SATA (serial ATA) or PATA (parallel ATA) interface connected with a USB conversion cable may not be recognized.
- Use a hard disk drive with a sufficient space for a copy operation.
- During a format or copy operation, do not unplug the cable, eject the target P2 card, or turn off the camera or the hard disk drive. Reboot of the camera and hard disk drive reboot may be required. For the power supply for the camera, use the fully charged battery or external DC power supply.
- Because the hard disk drive is a very sensitive device, there is a chance that you may not be able to read or write data depending on your usage.
- Please note that Panasonic has no responsibility for data loss caused from a hard disk drive failure or other defects and any direct or indirect damage related to these.
- If the contents of the hard disk drive used for a copy operation from the camera are replaced using another computer, the behavior of that hard disk drive with the camera or its data is not guaranteed afterwards.
- Use the drive mount converter published in the support desk at the following Web site to mount the connected hard disk drive to a specified folder.  
<http://pro-av.panasonic.net/>

## Connecting to the remote control unit (AJ-RC10G)

- Connect the remote control unit AJ-RC10G (optional) to remote-control some functions.
- When you connect AJ-RC10G and set the <POWER> switches of the camera and AJ-RC10G to <ON>, the camera automatically enters the remote control mode.

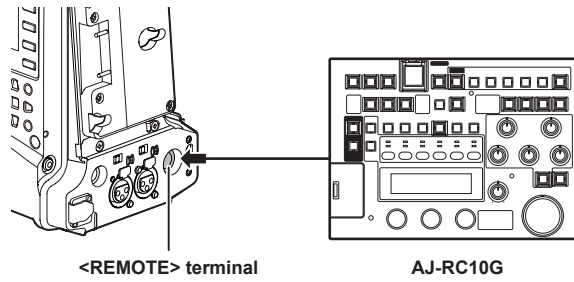

### NOTE

- When connecting and disconnecting the dedicated cable, ensure that you turn the <POWER> switches of the camera and AJ-RC10G to <OFF>.
- Do not use any cable other than the AJ-RC10G dedicated cable or dedicated optional cable. Doing so may result in a malfunction.
- The <USER> buttons (<USER MAIN>/<USER1>/<USER2>) and the <MENU> button do not activate during AJ-RC10G connection.
- Refer to the operating guide of "AJ-RC10G for AG-HPX600/610 series (AG-HPX600P/HPX610P/HPX600EJ/HPX610EJ/HPX600EN)" at the following website:  
<http://pro-av.panasonic.net/en/manual/index.html>
- For details on the current from the <REMOTE> terminal, refer to "Details of the connector signals" (page 173).

## Connecting to the extension control unit (AG-EC4G)

- Connect the extension control unit AG-EC4G (optional) to remote-control some functions.
- When you connect AG-EC4G and set the <POWER> switches of the camera and AG-EC4G to <ON>, the camera automatically enters the remote control mode.

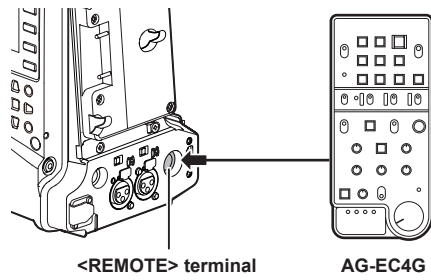

### NOTE

- When connecting and disconnecting the dedicated cable, ensure that you turn the <POWER> switches of the camera and AG-EC4G to <OFF>.
- Do not use any cable other than the AG-EC4G dedicated cable or dedicated optional cable. Doing so may result in a malfunction.
- The <USER> buttons (<USER MAIN>/<USER1>/<USER2>) and the <MENU> button do not activate during AG-EC4G connection.
- For details on the current from the <REMOTE> terminal, refer to “Details of the connector signals” (page 173).



## Chapter 10 **Maintenance and Inspection**

---

Inspect the various parts of the camera before recording. This chapter explains the warnings and error messages displayed on the viewfinder screen.

## Inspections before shooting

Before recording, perform the following inspection to ensure that the system operates properly. It is recommended that you check the image using a color video monitor.

### Preparing to inspect

- 1 Attach an adequately charged battery.
- 2 Turn the <POWER> switch <ON>, and check the battery charge level indicator on the viewfinder screen.

If the remaining battery level is low, replace the battery with an adequately charged one.

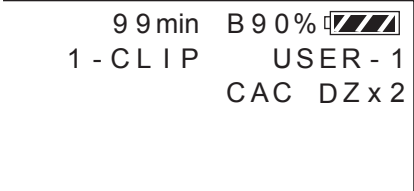

99 min B 90%   
1 - CLIP USER - 1  
CAC DZ x 2

- 3 Insert a P2 card into a card slot and close the slot cover.

- Ensure that the P2 card access LED lights in orange for the card slot to which the P2 card is inserted. If both card slots have P2 cards inserted, the orange access LED for the P2 card slot of the P2 card inserted first (the one that completed an access first) lights up, and the green P2 card access LED for the P2 card inserted second lights up.
- If the P2 card access LED for the P2 card slot to which the P2 card is inserted flashes in green or does not light up, that P2 card is not available for recording.

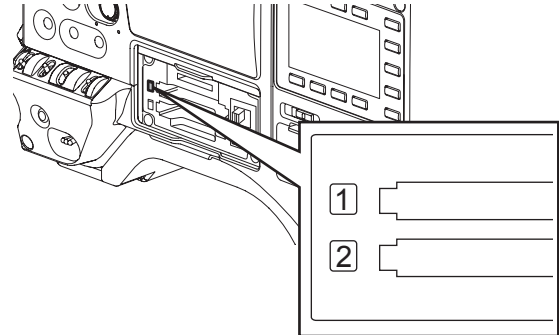

### Inspecting the camera unit

- 1 Set the zoom to the electric zoom mode and check the behavior of the electric zoom.  
Ensure that the image changes between telescopic and wide-angle.
- 2 Set the zoom to the manual zoom mode and check the behavior of the manual zoom.  
Rotate the manual zoom lever and ensure that the image changes between telescopic and wide-angle.
- 3 Set the iris to automatic adjustment mode, and ensure that the automatic adjustment works when the lens is pointed at objects with different degree of brightness.
- 4 Set the iris to manual mode and rotate the iris ring to check the manual iris adjustment.
- 5 Set the iris back to automatic adjustment mode, and check the followings by switching the <GAIN> switch setting to <L>, <M>, and then <H>:
  - The iris is adjusted for objects with same degree of brightness as the setting changes.
  - The gain value display on the viewfinder screen changes as the setting changes.
- 6 If a lens with an extender is attached, set the extender to its usage position to ensure that it works properly.

### Inspecting the memory recording functions

Perform procedures from “Inspecting the P2 card recording” to “Inspecting the earphone and speaker” successively.

#### Inspecting the P2 card recording

- 1 On the viewfinder screen display, ensure that the remaining P2 card capacity is sufficient.  
For details, refer to “Screen display” (page 71).
- 2 Press the <REC> button and check the following:
  - The orange P2 access LED flashes.
  - [REC] is displayed on the viewfinder screen.
  - No system warning is displayed on the viewfinder screen.
- 3 Press the <REC> button again.  
Ensure that the P2 access LED turns to orange, and that the [REC] display disappears from the viewfinder screen.
- 4 Use the <REC> button on the handle to check the same behaviors in steps 2 to 3.  
Perform the same inspection for the VTR button on the lens.
- 5 Press the <THUMBNAIL> button to switch to the thumbnail screen, and from the thumbnail, playback the clip you just recorded.  
Ensure that the clip plays back properly.
- 6 If two P2 cards are inserted in the P2 card slots, press the <USER> buttons (<USER MAIN>/<USER1>/<USER2>) to which [SLOT SEL] is assigned and switch the target P2 card.  
Perform steps 2 to 3 and step 5 to ensure that the recording and playback functions operate properly.

### Inspecting the audio level automatic adjustment

- 1 Press the <AUDIO> button to display the [AUD02:INPUT] screen of SmartUI.
- 2 Set the [IN] item in CH1/CH2 to [FRONT].
- 3 Set the [LVL] item in CH1/CH2 to [AUTO].

- Turn the microphone connected to the <MIC IN> terminal to an appropriate audio source, and ensure that both level displays for CH1/CH2 change according to the audio volume.

#### Inspecting the audio level manual adjustment

- Press the <AUDIO> button to display the [AUD02:INPUT] screen of SmartUI.
- Set the [IN] item in CH1/CH2 to [FRONT].
- Set the [LVL] item in CH1/CH2 to [MANU].
- Press the <AUDIO> button to display the [AUD01:LEVEL] screen of SmartUI.
- Turn the microphone connected to the <MIC IN> terminal to an appropriate audio source, and adjust the audio volume settings for CH1/CH2.
- Select the [+ ] item of CH1/CH2 to ensure that the level displays increase.

#### Inspecting the earphone and speaker

- Adjust the <MONITOR> dial and ensure that the speaker volume changes.
- Connect an earphone to the <PHONES> terminal.  
Ensure that the speaker is muted and the output from the microphone is directed to the earphone.
- Adjust the <MONITOR> dial and ensure that the earphone volume changes.

#### Inspections for using an external microphone

- Connect the external microphone to the <AUDIO IN CH1/3> and <AUDIO IN CH2/4> terminals and push the <LINE>/<MIC> selector switch towards the <MIC> side.
- Toggle the microphone input <+48V> ON/OFF switch according to the power supply for the external microphone.
- Press the <AUDIO> button to display the [AUD02:INPUT] screen of SmartUI.
- Set the [IN] item in CH1/CH2 to [REAR].
- Turn the microphone to an audio source, and confirm that the audio level display on the viewfinder screen or on SmartUI changes according to the audio volume.  
You can check each channel by connecting one microphone to each channel.

|        |   |
|--------|---|
| <+48V> | For microphones with an external power supply |
| <OFF>  | For microphones with an internal power supply |

#### Inspections for the clock, time code, and user bits

- Set the user bits as needed.  
For details, refer to “User bits settings” (page 64).
- Set the time code.  
For details, refer to “Setting the time code” (page 66).
- Press the <HOME> button to display the [HOME] screen of SmartUI.
- Press the <COUNTER> button to display [TC].
- Press the <SETUP> button to display the [SET01:TC/UB] screen of SmartUI.
- Set the [TC\_MD] item to [R-RUN].
- Press the <HOME> button to display the [HOME] screen of SmartUI.
- Press the <REC> button.  
Ensure that the number in the counter display changes when the recording starts.
- Press the <REC> button again.  
Ensure that the number in the counter display stops changing when the recording stops.
- Press the <SETUP> button to display the [SET01:TC/UB] screen of SmartUI.
- Set the [TC\_MD] item to [F-RUN].
- Press the <HOME> button to display the [HOME] screen of SmartUI.  
Ensure that the number in the counter display changes regardless of the recording status.
- Push the <DISP/MODE CHK> switch towards the <CHK> side and check the date and time displayed on the viewfinder screen.  
If [DATE], [TIME], or the time zone is incorrect, set the correct date/time (page 31).

#### NOTE

- Note that date and time data based on [DATE], [TIME], or the time-zone setting is recorded in the clip and affects the playback order in the thumbnail operations.

## Maintenance

---

### Charging the built-in battery

The camera uses the built-in battery to remember the date and time.

If the camera is not turned on for more than a half year, the built-in battery runs out and [🔋] may appear on the viewfinder screen.

In that case, connect an external DC power supply or a new battery and charge the built-in battery by leaving the camera turned off for approximately four hours. Set the date and time after the charge completes.

If [🔋] is still displayed after charging, the built-in battery needs to be replaced. Consult the shop of purchase.

## Warning system

### Warnings description list

If an error is detected immediately after the camera turns on or during operation, the <WARNING> lamp and the lamp on the viewfinder screen indicate the error.

| Priority | Warning type                  | Viewfinder screen display   | Tally lamp   | Warning lamp                                | Description of the warning and recording/playback behavior  | Action to take   |
|----------|-------------------------------|---|--|---|---|--|
| 1        | System error                  | [SYSTEM ERROR] factor display* <sup>1</sup> flashes in red.   | Flashes four times every second                              | Flashes four times every second             | Error in the P2 microcomputer or control. The current operation will stop.  | Check the factor display* <sup>1</sup> and consult the place of purchase.  |
| 2        | P2 card removal error         | [TURN POWER OFF] flashes in red.  | Flashes four times every second                              | Flashes four times every second             | An error occurred in the built-in memory because the P2 card being accessed was ejected. Both of the access LEDs flash in orange.   | Turn off the power. If the clip in the ejected P2 card contains errors, fix the errors.  |
| 3        | Battery empty                 | [LOW BATTERY] flashes in red and an empty remaining battery indicator bar flashes. (Displayed even if its display setting is turned off in the setting menu.) | Flashes once every second                                    | illuminated                                 | The battery has run out. Recording and playback will stop. If the voltage drops further, the power is automatically turned off.   | Change the batteries.  |
| 4        | P2 card fully recorded        | [P2] FULL] flashes in red.  | Flashes four times every second after the recording finishes | Lights up after the recording finishes      | The P2 card space is used up. Recording will stop.* <sup>3</sup>  | Delete some clips or insert a new card.  |
| 5        | Recording error               | [REC WARNING] factor display* <sup>2</sup> flashes in red.  | Flashes four times every second                              | Flashes four times every second             | Error in recording. The recording may stop or continue.* <sup>4</sup>   | Turn off the power and on again, and then check your recording and playback. If the recording operation fails, change the P2 card. |
| 6        | Corruption of standard signal | [TEMPORARY PAUSE IRREGULAR FRM SIG] flashes in red.   | Flashes four times every second                              | Flashes four times every second             | Correct recording is not possible due to corruption of the <GENLOCK IN> input signal, and the recording is suspended temporarily. The clip will be divided.<br>• Recording resumes when the signal returns to normal. However, recording does not resume in interval recording, one-shot recording, and loop recording. | Check the <GENLOCK IN> signal.   |
| 7        | Low wireless signal reception | [WIRELESS RF] flashes in red.   | Flashes four times every second (for recording only)         | Flashes four times every second             | The error indicates poor wireless audio reception condition. Recording continues without receiving the wireless microphone signal.  | Check the microphone power supply and the reception status of the wireless receiver.   |
| 8        | Battery nearly empty          | One remaining battery indicator bar flashes. (Also displayed when the [OTHER DISPLAY] item on the setting menu [DISPLAY SETUP] screen is set to [OFF].)       | Flashes once every second                                    | Flashes once every second                   | The battery is about to run out. The current operation will continue.* <sup>5</sup>   | Change the batteries as needed.  |
| 9        | P2 card nearly full           | The remaining P2 card capacity indicator flashes.   | Flashes once every second during recording.                  | Flashes once every second during recording. | The remaining P2 card capacity is two minutes or less (the remaining indicator display is less than one minute). This warning is issued only during recording.  | Change the P2 cards as needed or insert an additional card.  |

\*1 [P2 SYSTEM ERROR] factor display

- [P2 MICON ERROR]: P2 microcomputer is not responding.
- [P2 CONTROL ERROR]: Error occurred in the P2 recording control.
- [CAM MICON ERROR]: Camera microcomputer is not responding.

\*2 [REC WARNING] factor display

- [CARD ERROR\*]: Error in P2 card (the slot number of the error card is displayed on \*). Recording will stop.
- [REC RAM OVERFLOW]: Recording RAM overflow. Recording will stop.
- [PULL DOWN ERROR]: Image pull-down error in 24P, 25P, and 30P. Recording continues.
- [OVER MAX NUMBER CLIPS]: An attempt was made to record more than the maximum number of clips (1000) to one P2 card.
- [ERROR]: Other recording errors.

\*3 The warning stops if the following operations are made.

- Press the playback related buttons.
- Press the <THUMBNAIL> button.
- Eject the P2 card or insert another card.

\*4 The warning stops if the following operations are made.

- Press the <REC> button.

- Press the playback related buttons.
- Press the <THUMBNAIL> button.
- Eject all the cards.

\*5 The warning can be stopped by setting the [NEAR END CANCEL] item to [ON] and pushing the <DISP/MODE CHK> switch towards the <CHK> side.

### Error code

Indicates the error code on the [HOME] screen of SmartUI when something has caused an error on the camera. Check the types of warning, and deal with the error according to “Warnings description list” (page 157).



| Code No. | Description  | Type of warnings                              |
|----------|--|---|
| E-27     | Recording control error (viewfinder screen [P2 CONTROL ERROR])   | 1. System error                               |
| E-30     | P2 card removal error (viewfinder screen [TURN POWER OFF])   | 2. Card removal error                         |
| E-38     | P2 streaming microcontroller error (viewfinder screen [P2 MICON ERROR])  | 1. System error                               |
| E-3F     | Camera unit error (viewfinder screen [CAM MICON ERROR])  | 1. System error                               |
| E-40     | Error in image sequence, generator lock input signal, or SDI input signal (viewfinder screen [IRREGULAR FRM SIG], [PULL DOWN ERROR]) | 5. Recording error, 6. Reference signal error |
| 0000011  | Recording error to P2 cards, etc. (viewfinder screen [REC RAM OVERFLOW], [CARD ERROR*], [OVER MAX# CLIPS], [ERROR])                  | 5. Recording error                            |

### Card warning code

| Code No. | Description   | Recording  | Indication on SmartUI  |
|----------|---|--|--|
| E-70     | The directory structure on the P2 card is not supported. ([DIR ENTRY NG CARD] (slot number) is displayed on the viewfinder screen.)       | Operation continues, but immediately back up data on the card, and format the card before using it again.                | The warning code is displayed on the [HOME] screen of SmartUI. |
| E-71     | The maximum number of overwrites on the P2 card has been exceeded. ([RUN DOWN CARD] (slot number) is displayed on the viewfinder screen.) | Operation continues, but recording or playback may not be performed properly. Replacement of the P2 card is recommended. |  |

### Warning/error displays in the thumbnail operation and the USB host mode

#### ■ Thumbnail

| Message                  | Description   | Action to take  |
|--------------------------|---|---|
| CANNOT ACCESS!           | Data cannot be accessed due to a content defect or some other reason.   | Ensure the health of the media and the clips.   |
| CANNOT CHANGE!           | For a clip with the  mark, where a thumbnail cannot be generated with AVC-Intra 100 or AVC-Intra 50, the thumbnail cannot be modified in the text memo position. | Set the [SYSTEM MODE] item on the setting menu [SYSTEM SETUP] screen according to the clips.  |
| CANNOT COPY!             | Images cannot be copied.  | Check the copy conditions.  |
| CANNOT DELETE!           | Images cannot be deleted due to contents version mismatch.  | Match the device and contents version.  |
| CANNOT FORMAT!           | A P2 card problem or some other reason prevents formatting.   | Check the P2 card.  |
| CANNOT RE-CONNECT!       | Clips cannot be remerged because either clips that are not recorded across multiple P2 cards are selected or other reasons.   | Check the selected content.   |
| CANNOT REPAIR!           | Clips cannot be restored because contents that cannot be restored are selected or other reasons.  | Check the selected content.   |
| LACK OF CAPACITY!        | There is not enough recording capacity left on the card.  | Insert a card with sufficient recording capacity.   |
| MISSING CLIP!            | When all necessary P2 cards are not inserted, an attempt is made to add a shot mark to the clips recorded across multiple P2 cards.   | Insert all P2 cards with the recorded clips and ensure that the  incomplete clip indicator disappears, and then add the shot mark.       |
| NO CARD!                 | No P2 or SD card is inserted.   | Insert the relevant medium.   |
| NO COPY TO SAME CARD!    | A clip cannot be copied to the card storing the original clip.  | Copy the selected clip to a card that does not contain the original clip.   |
| NO FILE!                 | The specified file does not exist.  | Check the file.   |
| SAME CLIP IS SELECTED!   | Clips cannot be copied because the clips already copied and the original clips are selected.  | Check the selected clips, and remove either the original clips or copied clips, and then perform the copy operation.  |
| TOO MANY CLIPS!          | Too many clips are selected.  | Reduce the number of selected clips.  |
| UNKNOWN CONTENTS FORMAT! | Contents version is mismatched.   | Match the device and content versions.  |
| UNKNOWN DATA!            | The metadata character code is invalid.   | The metadata character code is UTF-8. Enter valid characters using a viewer.  |
| USER CLIP NAME MODIFIED! | Characters in the clip name had to be deleted when adding a counter value.  | For the counter addition setting, the user clip name plus the counter value can only contain up to 100 bytes. Characters in the clip name are automatically deleted when the total number of characters exceeds this limit. |
| WRITE PROTECTED!         | The P2 or SD card is write-protected.   | Insert write-enabled media.   |

■ Soft keyboard

| Message                       | Description  | Measure                                    |
|-------------------------------|--|--|
| CANNOT CHANGE!                | An attempt is made to enter a [PERSON] (user who enters the memo) when a text memo is not available. | Enter the [TEXT] (text information) first. |
| CANNOT SET!<br>INVALID VALUE! | The entered value is invalid.  | Change the input value.                    |

■ Hard disk drive (USB host mode)

| Message                     | Description   | Measure  |
|-----------------------------|---|--|
| CANNOT ACCESS CARD!         | An error occurred while accessing the P2 card.  | Check the P2 card.   |
| CANNOT ACCESS TARGET!       | An error occurred while accessing the connection target.  | Check the hard disk drive status or the connection.  |
| CANNOT FORMAT!              | The hard disk drive cannot be initialized.  | Change the connected hard disk drive.  |
| CANNOT RECOGNIZE HDD!       | The destination target cannot be properly recognized.   | Reboot the hard disk drive or connect another hard disk drive.   |
| CARD IS EMPTY! CANNOT COPY! | The P2 card to copy is empty.   | The copy operation is not performed because the card is empty.   |
| FORMAT P2 CARD!             | A warning indicates that the copy operation cannot be performed at the hard disk drive → P2 import because the P2 card is already recorded. | The copy operation cannot be performed because the target P2 card is not empty. Format the card using a P2 device and try again. |
| LACK OF CAPACITY!           | Not enough space left on the hard disk drive.   | There is not enough space on the connected target, so use a new hard disk drive or formatted hard disk drive.                    |
| HDD DISCONNECTED!           | The hard disk drive is disconnected.  | Reconnect the USB connection cable. If the hard disk drive does not operate properly, turn it off and turn it back on again.     |
| MISMATCH COMPONENT!         | The copy operation cannot be performed because the P2 card capacities and models do not match between the source and the target.            | Use the P2 cards of the same model, or import on a clip basis.   |
| TOO MANY PARTITIONS!        | There are too many partitions.  | The maximum number of partitions is 23, so use a new hard disk drive or formatted hard disk drive.                               |
| TOO MANY TARGETS!           | Multiple devices are connected.   | Disconnect the devices, turn off the camera, and then turn it back on again.   |
| UNKNOWN DEVICE CONNECTED!   | A non-compatible DVD drive or other device is connected.  | Disconnect the devices, turn off the camera, and then turn it back on again.   |
| VERIFICATION FAILED!        | The compare check performed after copying failed.   | Copy the data again.   |

## Updating the camera firmware

---

There are two ways to update the firmware:

**1 Use the dedicated tool P2\_Status\_Logger to check and apply the update.**

This option is available only to customers who register to PASS (P2 Asset Support System).

Log in to PASS and use the dedicated tool (P2\_Status\_Logger) to check the version information of your device and to access the download page of the required firmware.

For details about downloading and using P2\_Status\_Logger, refer to the pages displayed after logging in to PASS.

Other benefits are offered to registered customers. For details, refer to the PASS (P2 Asset Support System) site ([http://panasonic.biz/sav/pass\\_e](http://panasonic.biz/sav/pass_e)).

**2 Check the version using the camera and apply the update**

Check the version of the camera on the setting menu [DIAGNOSTIC] screen, and access the latest information about the firmware described in the following NOTE, and then download the firmware as needed.



**NOTE**

---

- Update completes by loading the downloaded files to the camera via the SD memory card. For details on update, visit the support desk at the following website:  
<http://pro-av.panasonic.net/>
- Use the SD memory card that complies to the SD or SDHC standard.  
Always use the camera to format the SD memory card.



## Chapter 11 **Additional Functions from the Optional Board**

---

High-resolution proxy video recording and high-quality recording with the digital input from the <SDI OUT/IN (OP)> terminal are available by installing an optional board to the camera.

## Video encoder board (AG-YDX600G)

When installing the video encoder board, consult the shop of purchase. For instructions to add the board, refer to the manual supplied with the video encoder board.

### ■ Video encoder board (AG-YDX600G)

Install this board to enable high-resolution proxy video recording.

The materials recorded with the camera can be converted to a compressed data file to save into a different area than that of the original materials. Images can be saved in high-resolution H.264/AVC format as well as MPEG4 format. For audio, besides AAC, uncompressed audio (LPCM) is supported.

In addition to the traditional MPEG4 format, the MOV format more suitable for nonlinear editing is available.

Video files, audio files, and real-time metadata file (time code, user bits, and UMID information) can be saved to the P2 card and SD memory card at the same time.

The recorded materials can be saved as a smaller data file to allow efficient clip check or editing.

### Proxy settings

#### Setting menu

When recording the proxy data using the camera, use the setting menu [PROXY SETTING] screen. After a video encoder board is added, the following setting menu becomes available.

| Item            | Description of settings   | Remark |   |
|-----------------|---|--------|---|
| REC MEDIA       | Selects media for recording proxy data.   | —      |   |
|                 | [P2]  |        | Records the proxy data to the P2 card.                                  |
|                 | [P2&SD]   |        | Records proxy data in both the P2 card and SD memory card.              |
|                 | [OFF]   |        | Does not record proxy data.   |
| REC MODE (1080) | Sets the recording mode of proxy data. (Only in 1080i mode)<br>For details on each mode, refer to "Recording modes and recording signals (video/audio)" (page 163).<br>[STD 2CH MP4], [SHQ 2CH MOV], [HQ 4CH MOV], [HQ 2CH MOV], [LOW 2CH MOV]                            | —      |   |
| REC MODE (720)  | Sets the proxy data recording mode when the 720P mode is selected. (Only in 720P mode)<br>For details on each mode, refer to "Recording modes and recording signals (video/audio)" (page 163).<br>[STD 2CH MP4], [SHQ 2CH MOV], [HQ 4CH MOV], [HQ 2CH MOV], [LOW 2CH MOV] | —      |   |
| REC MODE (SD)   | Sets the proxy data recording mode (in the SD mode only).<br>For details on each mode, refer to "Recording modes and recording signals (video/audio)" (page 163).<br>[STD 2CH MP4], [LOW 2CH MOV]   | —      |   |
| TC SUPER        | Sets superimposition of time code display on proxy data recorded images.  | —      |   |
|                 | [UPPER]   |        | Superimposes the time code display at the top of the recorded video.    |
|                 | [LOWER]   |        | Superimposes the time code display at the bottom of the recorded video. |
|                 | [OFF]   |        | Does not superimpose time code on recorded images.                      |
| PROXY DISP      | Sets whether to display a message ([PROXY REC P2] or [PROXY REC P2&SD]) when proxy recording starts.  | —      |   |
|                 | [ON]  |        | Displays a message.   |
|                 | [OFF]   |        | Does not display a message.   |

— indicates factory setting values.

- In the following modes, the proxy data is not recorded even if the [REC MEDIA] item is set to [P2] or [P2&SD].
  - Interval recording (including one-shot recording)
  - Loop recording
- The proxy function cannot be set when recording can be done to combine to the precedent clip during one-clip recording (when [1\*CLIP] is displayed). Close the menu and press the <STOP> button for approximately two seconds to stop combining to the clip, and try the operations again.
- The proxy setting menu may change if the SD memory card data, where the user file settings are saved with [WRITE] selected at the [USER FILE] item on the setting menu [CARD FUNCTIONS] screen using the camera without this board, is read into the camera with this board.

#### Checking the setting status

Push the <DISP/MODE CHK> switch on the camera towards the <CHK> side twice to check the menu values of [REC MEDIA], [REC MODE], and [TC SUPER] with the mode check function.

#### Checking the version information

The following version information is displayed in the [VERSION] item of the setting menu [DIAGNOSTIC] screen.

| Item       | Description of settings                          | Remark |
|------------|--|--------|
| PROXY SOFT | The software version of this board is displayed. |        |
| PROXY FPGA | The FPGA version of this board is displayed.     |        |

**Recording modes and recording signals (video/audio)**

| Recording mode | File format | Video  |                        |                              |           | Audio  |                    |                      |                    |
|----------------|-------------|--|------------------------|------------------------------|-----------|--------|--------------------|----------------------|--------------------|
|                |             | Resolution   | Codec                  | Frame rate                   | Bit rate  | Codec  | Number of channels | Bit rate per channel | Sampling frequency |
| STD 2CH MP4    | MP4         | 320×240 (QVGA)   | MPEG-4 Simple Profile  | 30 fps/<br>24 fps/<br>25 fps | 1500 kbps | AAC-LC | 2ch                | 64 kbps              | 24 kHz             |
| SHQ 2CH MOV    | MOV         | 960×540  | H.264 High Profile     | 30 fps/<br>24 fps/<br>25 fps | 3500 kbps | LPCM   | 2ch                | 768 bps              | 48 kHz             |
| HQ 4CH MOV     | MOV         | 640×360  | H.264 High Profile     | 30 fps/<br>24 fps/<br>25 fps | 1500 kbps | AAC-LC | 4ch                | 64 kbps              | 48 kHz             |
| HQ 2CH MOV     | MOV         | 640×360  | H.264 High Profile     | 30 fps/<br>24 fps/<br>25 fps | 1500 kbps | AAC-LC | 2ch                | 64 kbps              | 48 kHz             |
| LOW 2CH MOV    | MOV         | 1080i mode<br>480×270<br>720-30P mode<br>480×270<br>720-24P mode<br>480×270<br>720-25P mode<br>480×270<br>480-59.94i mode<br>352×240 (SIF_NTSC)<br>576-50i mode<br>352×288 (SIF_PAL) | H.264 Baseline Profile | 30 fps/<br>24 fps/<br>25 fps | 800 kbps  | AAC-LC | 2ch                | 64 kbps              | 48 kHz             |
|                |             | 720-59.94P mode<br>320×180<br>720-50P mode<br>320×180  |                        | 60 fps/<br>50 fps/           |           |        |                    |                      |                    |

**Recording the proxy data**

Set the [REC MEDIA] item to [P2] or [P2&SD] and press the <REC> button to start proxy recording at the same time as recording of the sources. Push the <DISP/MODE CHK> switch towards the <CHK> side twice to display the proxy data recording information on the viewfinder screen.

**Recording to the SD memory card**

To record the proxy data, use Panasonic SD or SDHC memory cards with an indication of class 2 or higher. Refer to our support page at the following website for the latest information not included in these operating instructions.

<http://pro-av.panasonic.net/>

When recording the proxy data to an SD memory card, always format the card using the camera.

**Checking the SD memory card**

- 1** Insert the SD memory card into the camera.
- 2** Press the <THUMBNAIL> button to display the thumbnail screen.
- 3** Press the <THUMBNAIL MENU> button.

**4** Use the cursor buttons and the <SET> button to select [PROPERTY] → [DEVICES] → [SD CARD].

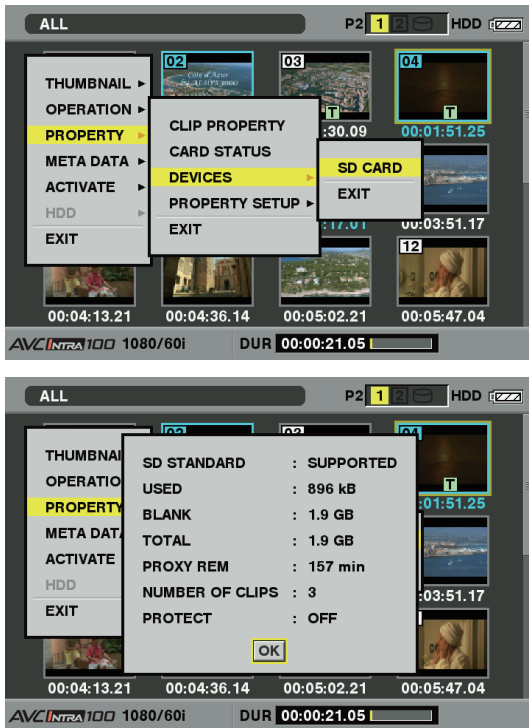

- The format status is displayed in the [SD STANDARD] item. If [NOT SUPPORTED] is displayed, format the card with the camera.

- In the [PROXY REM] item, check the remaining recording time of the proxy data.  
The remaining SD memory card capacity displayed (PROXY REM) indicates the remaining proxy recording, but it may differ from the actual available space. If short recordings are repeated, the available recording time may decrease significantly compared to the available space. When the remaining capacity exceeds 999 min, [999min] is displayed.  
If the proxy is not recorded to the SD memory card, the remaining time is not displayed.
- In the [NUMBER OF CLIPS] item, check the number of clips recorded in the SD memory card.  
If the number of clips exceeds 1000, no additional proxy data can be recorded to the SD memory card even if there is available capacity.
- Shot marks and text memos cannot be added to the clips in the SD memory card,
- Deleting the clips recorded on the P2 card on the thumbnail screen does not delete the proxy data recorded on the SD memory card.
- The proxy data cannot be recorded to the SD memory card containing data for updating.

**NOTE**

- While recording to the SD memory card, the remaining capacity can be checked with the mode check on the viewfinder screen.
- If the [REC MEDIA] item on the setting menu [PROXY SETTING] screen is set to [P2&SD] and the proxy data cannot be recorded to the SD memory card, [SD CARD WRITE ERR] is displayed when recording starts. In that case, check the SD memory card. For details, refer to “Error displays about proxy data recordings” (page 165).
- Data deleted as a result of formatting cannot be restored. Always check the data before formatting.

**Formatting the card**

- 1** Insert the SD memory card into the camera.
- 2** Press the <THUMBNAIL> button to display the thumbnail screen.

**3** Press the <THUMBNAIL MENU> button.

- 4** Use the cursor buttons and the <SET> button to select [OPERATION] → [FORMAT] → [SD CARD] → [YES].

This completes formatting the SD memory card.

**Proxy data recording time (approximate)**

| Recording mode | Total recording rate | Recording time (per 1 GB) |
|----------------|----------------------|---------------------------|
| STD 2CH MP4    | Approx. 1650 kbps    | Approx. 78 min            |
| SHQ 2CH MOV    | Approx. 5060 kbps    | Approx. 25 min            |
| HQ 4CH MOV     | Approx. 1780 kbps    | Approx. 72 min            |
| HQ 2CH MOV     | Approx. 1650 kbps    | Approx. 78 min            |
| LOW 2CH MOV    | Approx. 950 kbps     | Approx. 135 min           |

(These are reference values for continuous recording with Panasonic products. The recording time may differ depending on the scene or the number of clips.)

**Proxy recording in one-clip recording mode**

Proxy recording is possible even in the one-clip recording mode. Since proxy data is also grouped together in the same way as a combined clip, it can be handled as a single clip in P2 Viewer Plus, for example. However, note the following when recording the proxy data to SD memory cards.

- When the SD memory card is removed and replaced while combining of clips is in progress, proxy recording is not performed to the SD memory card until combining of subsequent clips ends. Check available space and the number of the files (maximum 1000 clips) before using the card. In case you want to continue proxy recording after changing the SD memory cards during the process, press the <STOP> button for two seconds to finish the merge, and start recording as a new clip.
- The proxy data in the SD memory card that the recording interrupted does not match the clip data recorded to the P2 card, resulting in incomplete data.
- During a clip merge, some menu items displayed in the [PROXY SETTING] screen cannot be changed. Press the <STOP> button for approximately two seconds to stop combining to the clip, and try the operations again.

**Checking the proxy data**

- The [P] indicator is displayed for the material clips with the proxy data recorded.
- The detailed information of the recorded proxy data can be viewed in the clip property.  
For details on operations, refer to “Checking detailed information of the proxy data” (page 165).
- The proxy data is recorded to the P2 card or SD memory card as a video/audio file and real-time metadata file.

- Video/audio file:XXXXXXXX.MP4 or XXXXXXXX.MOV
  - Real-time metadata file:XXXXXXXX.BIN
- The time code, user bits, and UMID information are recorded to the frame unit.

Use P2 Viewer Plus to check the proxy data. Some versions of P2 Viewer Plus may not be able to check the data.

For information on P2 Viewer Plus, visit the following website:  
<http://pro-av.panasonic.net/>

**NOTE**

- Since clips with the proxy data recorded with this board mounted will be treated as unknown clips in some P2 devices, **[?]** (unknown clip indicator) is displayed on their thumbnails and the following operations are not available. (Except in the [STD 2CH MP4] mode)
  - [DELETE]
  - [REPAIR CLIP]
  - [RE-CONNECTION]
  - [COPY]
  - [EXCH. THUMBNAIL]
  - Adding and deleting [TEXT MEMO] and [SHOT MARK]
 Playback is supported.
- On these devices, individual clips with proxy data combined from multiple clips are displayed as an incomplete clip **[■]**. (Except in [STD 2CH MP4] mode)

**Checking detailed information of the proxy data**

The operation method or the panels may differ based on the models and versions of the camera.

**1 Press the <THUMBNAIL> button.**

The thumbnail screen appears on the viewfinder screen.

**2 Press the <THUMBNAIL MENU> button and select [PROPERTY] → [CLIP PROPERTY] from the thumbnail menu.**

A screen like the one below is displayed. Use the cursor buttons to move the cursor to the [PROXY] item.

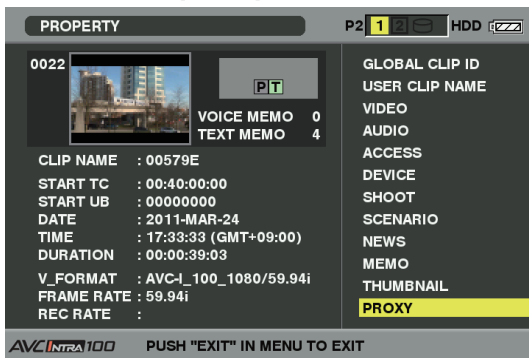

|                       |   |
|-----------------------|---|
| [FORMAT]              | The file format of the recorded data is displayed.  |
| [VIDEO CODEC]         | Video codec information of the recorded data is displayed.                                |
| [VIDEO FRAME RATE]    | Video frame rate information of the recorded data is displayed.                           |
| [VIDEO BIT RATE]      | Video bit rate information of the recorded data is displayed.                             |
| [VIDEO RESOLUTION]    | The video resolution of the recorded data is displayed.                                   |
| [ASPECT RATIO]        | The aspect ratio of the recorded data is displayed.                                       |
| [TC SUPER]            | An indication whether the TC (time code) display is superimposed over the recorded video. |
| [AUDIO CODEC]         | Audio codec information of the recorded data is displayed.                                |
| [AUDIO BIT RATE]      | Audio bit rate information of the recorded data is displayed.                             |
| [AUDIO SAMPLING RATE] | Audio sampling rate information of the recorded data is displayed.                        |
| [NUM.OF AUDIO CH]     | The number of audio channels of the recorded data is displayed.                           |

**3 Press the <SET> button.**

Detailed information about the proxy data is displayed as below.

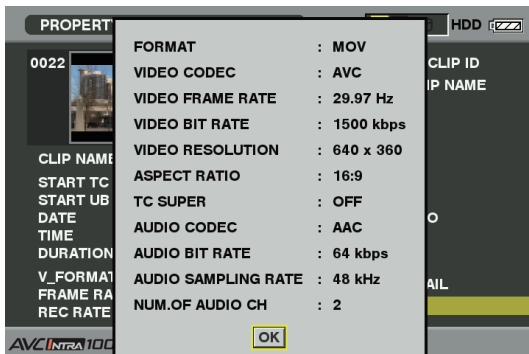

**Error displays about proxy data recordings**

If an error occurs during recording the proxy data, check the entries in the following table and take necessary actions.

| Error displays (viewfinder screen)         | Behavior and cause  | Action to take  |
|--|---|---|
| [PROXY BOARD ERROR] or [PROXY REC WARNING] | Proxy data recording will stop, but recording of the original material will continue. <ul style="list-style-type: none"> <li>• Error in the board<br/>[PROXY BOARD ERROR]</li> <li>• Proxy data recording error<br/>[PROXY REC WARNING]</li> <li>• If a proxy data recording error occurs, the proxy data currently being recorded will be processed as below:                             <ul style="list-style-type: none"> <li>- The proxy data being recorded to the P2 card will be deleted.</li> <li>- The proxy data being recorded to the SD memory card will not be restored.</li> </ul> </li> </ul>   | The proxy data will not be properly recorded. Turn the camera off and turn it back on again to check the recording and playback.  |
| [NEAR END (SD)]                            | Recording of the original materials and proxy data will continue. <ul style="list-style-type: none"> <li>• The remaining SD memory card capacity is getting low (approximately shorter than one minute).</li> </ul>   | After finishing recording, insert a new SD memory card.   |
| [EOM (SD)]                                 | Proxy data recording to the SD memory card will stop, but recording to the P2 card will continue. <ul style="list-style-type: none"> <li>• The remaining SD memory card capacity ran out.</li> </ul>  | After finishing recording, insert a new SD memory card. <ul style="list-style-type: none"> <li>• The proxy data being recorded to the SD memory card will be deleted.</li> </ul> To restore the deleted proxy data, select clips in the P2 card and copy them to the SD memory card. (page 166) |
| [SD CARD WRITE ERR]                        | Proxy data recording to the SD memory card will stop, but recording to the P2 card will continue.<br>This error message is displayed when the [REC MEDIA] item on the setting menu [PROXY SETTING] screen is set to [P2&SD] and the proxy data cannot be recorded to the SD memory card. <ul style="list-style-type: none"> <li>■ If the error message is displayed when recording starts:                             <ul style="list-style-type: none"> <li>• The SD memory card format is different</li> <li>• The SD memory card contains more than 1000 clips</li> <li>• An attempt is made to record to an SD memory card containing data for updating the firmware of the camera.</li> </ul> </li> <li>■ If the error message is displayed during recording:                             <ul style="list-style-type: none"> <li>• The SD memory card was ejected during recording</li> <li>• An error occurred in recording to the SD memory card</li> </ul> </li> </ul> | Check the status of the SD memory card and insert a recordable card. (page 163)   |
| [NO SD CARD!] or [SD CARD PROTECTED]       | Proxy data will not be recorded to the SD memory card, but recording to the P2 card will be performed. <ul style="list-style-type: none"> <li>• No SD memory card is inserted. [NO SD CARD!]</li> <li>• The SD memory card is write-protected. [SD CARD PROTECTED]</li> </ul>   | Check the status of the SD memory card.   |

### Copying the proxy data to a SD memory card

- 1 Press the <THUMBNAIL> button to display the thumbnail screen.
- 2 Use the cursor buttons to move the pointer to the clip to be copied, and press the <SET> button.
- 3 Press the <THUMBNAIL MENU> button.
- 4 Use the cursor buttons and the <SET> button to select [OPERATION] → [COPY] → [SD CARD] → [YES].

#### NOTE

- If [EOM (SD)] is displayed and the proxy data being recorded to the SD memory card is deleted, perform this procedure to copy the proxy data from the P2 card, and enable the deleted proxy data to be restored.
- The original materials will not be copied.

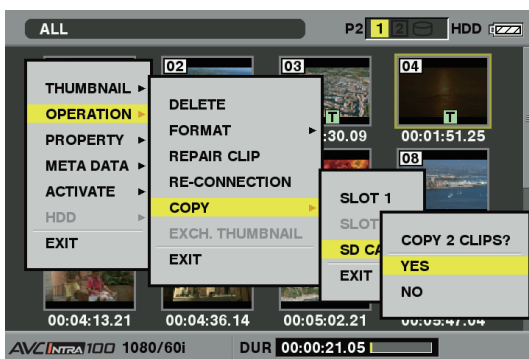

## HD/SD SDI input board (AG-YA600G)

High-quality recording with the digital input from the <SDI OUT/IN (OP)> terminal is available by installing the HD/SD SDI input board (AG-YA600G). When installing the board, consult the shop of purchase. For instructions to install the board, refer to the manual supplied with the HD/SD SDI input board.

### ■ HD/SD SDI input board (AG-YA600G)

High-quality recording with the digital input from the <SDI OUT/IN (OP)> terminal is available by installing this board.

In the HD mode, recording can be started and stopped automatically using the information added to the HD SDI input signal. (Auto recording function)

#### • SDI input settings

To record the SDI input signal with the camera, select [SDI IN] at the [REC SIGNAL] item on the setting menu [SYSTEM SETUP] screen.

For details, refer to the [REC SIGNAL] item (page 122).

| Item       | Description of settings   |   |
|------------|---------------------------|---|
| REC SIGNAL | Selects the input signal. |   |
|            | [CAMERA]                  | Records the camera shooting signal of the camera.                 |
|            | [SDI IN]                  | Records the SDI input signal from the <SDI OUT/IN (OP)> terminal. |

#### • Auto recording function setting

To enable the auto recording function with the camera, select [TYPE1] or [TYPE2] at the [AUTO REC] item on the setting menu [IN/OUT SEL] screen.

For details, refer to "AUTO REC (OP2)" (page 127).

| Item     | Description of settings |   |
|----------|-------------------------|---|
| AUTO REC | [TYPE1]                 | Performs automatic recording by detecting from LTC of the HD SDI input signal.  |
|          | [TYPE2]                 | Performs automatic recording by detecting from VITC of the HD SDI input signal. |
|          | [OFF]                   | Does not perform automatic recording.   |

# Chapter 12 **Specification**

---

This chapter describes the dimensions, specifications, and connector signals.



## Dimensions and specifications

### Dimensions

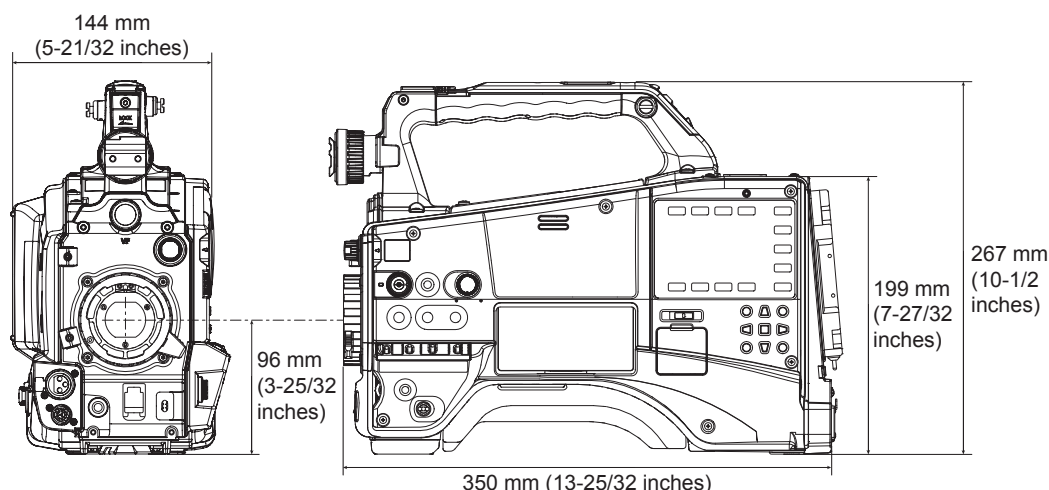

### Specifications

#### General

Power  
 DC 12 V (11.0 V – 17.0 V)  
 Power consumption  
 22 W (when the optional boards AG-YDX600G and AG-YA600G are installed)  
 18 W (body only)  
 58 W (with all optional accessories connected and maximum power supplied from each output terminal)

indicates safety items.

|                               |   |
|-------------------------------|---|
| Ambient operating temperature | 0°C to 40°C (32°F to 104°F)   |
| Ambient operating humidity    | 10% to 85% (relative humidity)  |
| Storage temperature           | -20°C to 60°C (-4°F to 140°F)   |
| Weight                        | Approx. 2.8 kg (6.2 lbs.) (body only, excluding the battery and accessories)                                  |
| Continuous operation time     | Approx. 240 minutes (when using Anton/Bauer DIONIC90: when the optional AG-CVF10G is installed)               |
| Dimensions (W×H×D)            | Body only<br>144 mm×267 mm×350 mm<br>(5-21/32 inches×10-1/2 inches×13-25/32 inches)<br>(excluding protrusion) |

#### Camera unit

|                                 |  |   |
|---------------------------------|--|---|
| Pickup devices                  | 2/3-type, MOS×1  |   |
| Lens mount                      | 2/3-type bayonet   |   |
| ND filter                       | 4-position (CLEAR, 1/4ND, 1/16ND, 1/64ND)                                      |   |
| Gain settings                   | -3, 0, 3, 6, 9, 12, 18 dB (for 18 dB, assign [GAIN:18dB] to the <USER> button) |   |
| Color temperature settings      | ATW, ATW LOCK, Ach, Bch, preset 3200 K, preset 5600 K, VAR (2400 K to 9900 K)  |   |
| Shutter speed                   | When [SYSTEM MODE] = 59.94 Hz  |   |
|                                 | 60i/60p mode   | 1/60 (off), 1/100, 1/120, 1/250, 1/500, 1/1000, 1/2000 sec. |
|                                 | 30P mode   | 1/30 (off), 1/50, 1/60, 1/120, 1/250, 1/500, 1/1000 sec.    |
|                                 | 24P mode   | 1/24 (off), 1/50, 1/60, 1/120, 1/250, 1/500, 1/1000 sec.    |
|                                 | When [SYSTEM MODE] = 50 Hz   |   |
|                                 | 50i/50P mode   | 1/50 (off), 1/60, 1/120, 1/250, 1/500, 1/1000, 1/2000 sec.  |
|                                 | 25P mode   | 1/25 (off), 1/50, 1/60, 1/120, 1/250, 1/500, 1/1000 sec.    |
| Shutter speed<br>(Synchro scan) | When [SYSTEM MODE] = 59.94 Hz<br>When [SYNC SCAN TYPE] = [sec]                 |   |
|                                 | 60i/60p mode   | 1/60.0 – 1/249.8 seconds                                    |
|                                 | 30P mode   | 1/30.0 – 1/249.8 seconds                                    |
|                                 | 24P mode   | 1/24.0 – 1/249.8 seconds                                    |
|                                 | When [SYSTEM MODE] = 50 Hz<br>When [SYNC SCAN TYPE] = [sec]                    |   |
|                                 | 50i/50P mode   | 1/50.0 – 1/250.0 seconds                                    |
|                                 | 25P mode   | 1/25.0 – 1/250.0 seconds                                    |

## Chapter 12 Specification — Dimensions and specifications

|                       |  |   |
|-----------------------|--|---|
| Shutter speed (slow)  | Available only when the [VFR] item on the setting menu [SCENE FILE] screen is set to [OFF]<br>When [SYSTEM MODE] = 59.94 Hz                              |   |
|                       | 60i/60p mode   | 1/15, 1/30 seconds  |
|                       | 30P mode   | 1/15 seconds  |
|                       | 24P mode   | 1/12 seconds  |
|                       | When [SYSTEM MODE] = 50 Hz   |   |
|                       | 50i/50P mode   | 1/12.5, 1/25 seconds  |
| Shutter open angle    | Available only when the [VFR] item on the setting menu [SCENE FILE] screen is set to [OFF]<br>Configurable between 3 deg and 360 deg (in a 0.5 deg step) |   |
|                       | Available only when the [VFR] item of the [SCENE FILE] screen on the setting menu is set to [ON]*1   |   |
|                       | [FRAME RATE] setting is more than 12P  | Configurable between 3 deg and 360 deg (in a 0.5 deg step)                                      |
|                       | [FRAME RATE] setting is less than 12P  | Configurable between 3 deg and 22.5 deg (in a 0.5 deg step)<br>45 deg, 90 deg, 180 deg, 360 deg |
| Variable frame rate*1 | 1080-59.94i  | 1/2/4/6/9/12/15/18/20/21/22/24/25/26/27/28/30 (frame/sec.)                                      |
|                       | 1080-50i   | 1/2/4/6/9/12/15/18/20/21/22/23/24/25 (frame/sec.)   |
|                       | 720-59.94P   | 1/2/4/6/9/12/15/18/20/21/22/24/25/26/27/28/30/32/34/36/40/44/48/54/60 (frame/sec.)              |
|                       | 720-50P  | 1/2/4/6/9/12/15/18/20/21/22/23/24/25/26/27/28/30/32/34/37/42/45/48/50 (frame/sec.)              |
| Sensitivity*2         | F12 (2000 lx, 3200 K, 89.9% reflection, 1080/59.94i)   |   |
|                       | F13 (2000 lx, 3200 K, 89.9% reflection, 1080/50i)  |   |
| Image S/N*2           | 59 dB (standard)   |   |
| Digital zoom          | ×2, ×4   |   |

\*1 Can be set when the upgrade software key AG-SFU602G (production pack (extra-cost option)) is installed.

\*2 When the [SHOOTING MODE] item of the [SYSTEM SETUP] screen on the setting menu is set to [LOW LIGHT].

### Memory card recorder

|                             |   |   |
|-----------------------------|---|---|
| Recording media             | P2 memory card, microP2 memory card (microP2 card adaptor required)   |   |
| System format               | 1080-59.94i, 1080-23.98PsF*, 720-59.94P, 480-59.94i, 1080-50i, 720-50P, 576-50i   |   |
| Recording format            | AVC-Intra 100/AVC-Intra 50/DVCPRO HD/DVCPRO50/DVCPRO/DV format switch   |   |
| Recording video signal      | 1080/59.94i, 1080/29.97P, 1080/29.97PN, 1080/23.98P, 1080/23.98PA, 1080/23.98PN, 720/59.94P, 720/29.97P, 720/29.97PN, 720/23.98P, 720/23.98PN, 480/59.94i, 480/29.97P, 480/23.98P, 480/23.98PA, 1080/50i, 1080/25P, 1080/25PN, 720/50P, 720/25P, 720/25PN, 576/50i, 576/25P |   |
| Recording and playback time | AVC-Intra 100   | 16 GB×1 approx. 16 min, 16 GB×2 approx. 32 min<br>32 GB×1 approx. 32 min, 32 GB×2 approx. 64 min<br>64 GB×1 approx. 64 min, 64 GB×2 approx. 128 min     |
|                             | AVC-Intra 50  | 16 GB×1 approx. 32 min, 16 GB×2 approx. 64 min<br>32 GB×1 approx. 64 min, 32 GB×2 approx. 128 min<br>64 GB×1 approx. 128 min, 64 GB×2 approx. 256 min   |
|                             | DVCPRO HD   | 16 GB×1 approx. 16 min, 16 GB×2 approx. 32 min<br>32 GB×1 approx. 32 min, 32 GB×2 approx. 64 min<br>64 GB×1 approx. 64 min, 64 GB×2 approx. 128 min     |
|                             | DVCPRO50  | 16 GB×1 approx. 32 min, 16 GB×2 approx. 64 min<br>32 GB×1 approx. 64 min, 32 GB×2 approx. 128 min<br>64 GB×1 approx. 128 min, 64 GB×2 approx. 256 min   |
|                             | DVCPRO/DV   | 16 GB×1 approx. 64 min, 16 GB×2 approx. 128 min<br>32 GB×1 approx. 128 min, 32 GB×2 approx. 256 min<br>64 GB×1 approx. 256 min, 64 GB×2 approx. 512 min |
|                             | Recording playback time becomes 1.25 times longer in 24PN native recording.<br>The times above are for continuous recording of one clip. Depending on the number of clips, the overall recording time may be shorter than the above.  |   |

\* Available only when the upgrade software key AG-SFU602G (production pack (extra-cost option)) is installed.

### Digital video

|                          |                               |   |
|--------------------------|-------------------------------|---|
| Sampling frequency       | AVC-Intra 100/<br>DVCPRO HD   | Y: 74.1758 MHz, P <sub>B</sub> /P <sub>R</sub> : 37.0879 MHz (59.94 Hz)<br>Y: 74.2500 MHz, P <sub>B</sub> /P <sub>R</sub> : 37.1250 MHz (50 Hz) |
|                          | DVCPRO50                      | Y: 13.5 MHz, P <sub>B</sub> /P <sub>R</sub> : 6.75 MHz  |
|                          | DVCPRO                        | Y: 13.5 MHz, P <sub>B</sub> /P <sub>R</sub> : 3.375 MHz   |
|                          | Quantizing                    |   |
| Video compression format | AVC-Intra 100<br>AVC-Intra 50 | MPEG-4 AVC/H.264 Intra Profile  |
|                          | DVCPRO HD                     | DV-Based Compression (SMPTE 370M)   |
|                          | DVCPRO50<br>DVCPRO            | DV-Based Compression (SMPTE 314M)   |
|                          | DV                            | DV Compression (IEC 61834-2)  |

**Digital audio**

|                        |   |
|------------------------|---|
| Recording audio signal | AVC-Intra 100/AVC-Intra 50/DVCPRO HD<br>48 kHz/16 bits, 4ch |
|                        | DVCPRO50<br>48 kHz/16 bits, 4ch                             |
|                        | DVCPRO/DV<br>48 kHz/16 bits, 2ch/4ch switch                 |
| Headroom               | 20 dB/18 dB (switchable menu)                               |

**Video input/output**

|                            |  |
|----------------------------|--|
| <SDI OUT/IN (OP)> terminal | HD SDI = BNC×1, 0.8 V [p-p], 75 Ω<br>SD SDI = BNC×1, 0.8 V [p-p], 75 Ω<br>When the HD/SD SDI input board (extra-cost option) is installed, the SDI input function is available (switched the SDI input in the menu). |
| <MON OUT> terminal         | HD SDI = BNC×1, 0.8 V [p-p], 75 Ω<br>SD SDI = BNC×1, 0.8 V [p-p], 75 Ω<br>VBS = BNC×1, 1.0 V [p-p], 75 Ω (Can be switched to HD SDI/SD SDI/VBS with the SmartUI setting.)  |
| <HDMI> terminal            | HDMI×1 (HDMI type A terminal, not compatible with VIERA Link)  |

**Audio input/output**

|                      |  |
|----------------------|--|
| <MIC IN> terminal    | <ul style="list-style-type: none"> <li>• XLR (3-pin)×1</li> <li>- +48 V supporting menu</li> <li>- -40 dBu/-50 dBu/-60 dBu (switchable menu)</li> </ul>  |
| <AUDIO IN> terminal  | <ul style="list-style-type: none"> <li>• XLR (3-pin)×2</li> <li>Input high impedance, &lt;LINE&gt;/&lt;MIC&gt; (switch)</li> <li>- LINE: 0 dBu</li> <li>- MIC: -50/-60 dBu (menu), MIC+48 V ON/OFF (switch)</li> </ul> |
| WIRELESS IN terminal | 25-pin, D-SUB, -40 dBu, 2ch supported  |
| <AUDIO OUT> terminal | Pin jack×2 (CH1, CH2), output: 316 mV, 600 Ω   |
| Speaker              | 20 mm diameter, round×1  |

**Other input/output**

|                            |   |
|----------------------------|---|
| <GENLOCK IN> terminal      | BNC×1, 1.0 V [p-p], 75 Ω  |
| <TC IN/OUT> terminal       | <ul style="list-style-type: none"> <li>• TC IN/OUT menu</li> <li>- IN: BNC×1, 0.5 V [p-p] to 8 V [p-p], 10 kΩ</li> <li>- OUT: BNC×1, 2.0±0.5 V [p-p], low impedance</li> </ul>        |
| <DC IN> terminal           | XLR×1, 4-pin, DC 12 V (DC 11.0 V to 17.0 V)   |
| <DC OUT> terminal          | 4-pin, DC 12 V (DC 11.0 V to 17.0 V), maximum output current 1.5 A  |
| <REMOTE> terminal          | 10-pin  |
| <LENS> terminal            | 12-pin  |
| <VF> terminal              | 20-pin  |
| <LAN> terminal*            | 100BASE-TX/10BASE-T   |
| <USB2.0> terminal (device) | Placed on the right side of the body. Type B, 4-pin, USB ver.2.0 compliance   |
| <USB2.0> terminal (host)   | Placed on the right side of the body. Type A, 4-pin, USB ver.2.0 compliance   |
| <USB2.0> terminal (host)*  | Placed inside the cover on the left side of the body. Type A, 4-pin, USB ver.2.0 compliance, for attachment of the wireless module AJ-WM30 or attachment of the USB cable for UPLINK. |

\* When the upgrade software key AG-SFU601G (network function (extra-cost option)) is installed, the network functions of the wired LAN and wireless LAN are enabled.

The UPLINK device control function is available when the Upgrade Software Key AG-SFU603G (UPLINK device control function (extra-cost option)) is installed.

**Options**

|                       |   |
|-----------------------|---|
| Color viewfinder      | AG-CVF10G/AG-CVF15G                         |
| Video encoder board   | AG-YDX600G                                  |
| HD/SD SDI input board | AG-YA600G                                   |
| Wireless module       | AJ-WM30                                     |
| Upgrade Software Key  | AG-SFU601G/AG-SFU602G/AG-SFU603G/AG-SFU604G |

**Supported formats when the video encoder board (AG-YDX600G) is installed**

|                          |  |
|--------------------------|--|
| Weight                   | Approx. 50 g (0.11 lbs.)   |
| Dimensions (W×H×D)       | 149 mm×55 mm×31 mm<br>(5-7/8 inches×2-5/32 inches×1-7/32 inches)             |
| File format              | MP4 (ISO/IEC14496 standard)<br>MOV (QuickTime format)                        |
| Video compression format | MPEG4 Simple Profile<br>H.264/AVC Baseline Profile<br>H.264/AVC High Profile |
| Audio recording format   | AAC-LC<br>Linear PCM   |

For details on recording modes, refer to “Recording modes and recording signals (video/audio)” (page 163).

**Supported formats when the HD/SD SDI input board (AG-YA600G) is installed**

|  |  |
|--|--|
| Weight   | Approx. 13 g (0.03 lbs.)   |
| Dimensions (W×H×D)   | 70 mm×50 mm×7 mm<br>(2-3/4 inches×1-31/32 inches×9/32 inches)  |
| Video format (complies to the AG-HPX610P/AG-HPX610EJ video format) | HD: 1080/59.94i, 1080/50i, 720/59.94P, 720/50P<br>SD: 480/59.94i, 576/50i  |
| Audio format (complies to the AG-HPX610P/AG-HPX610EJ audio format) | 48 kHz, 16 bits, CH4 (AVC-Intra 100, AVC-Intra 50, DVCPRO HD, DVCPRO50)<br>48 kHz, 16 bits, CH2/CH4 switch (DVCPRO/DV) |

## Details of the connector signals

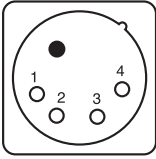
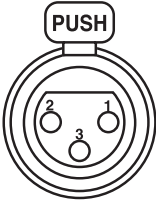
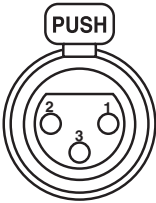
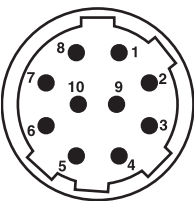
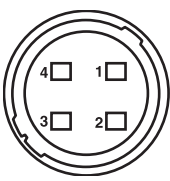
| DC IN   |    |                          |
|---|----|--------------------------|
|                      | 1  | GND                      |
|   | 2  | NC                       |
|   | 3  | NC                       |
|   | 4  | +12 V                    |
| Panasonic Parts No: K1AA104H0038<br>Manufacturer Parts No: HA16RX-4P (SW1) (76) (Hirose Electric Co.) |    |                          |
| <b>NOTE</b><br>* Make sure that the polarity of the external power supply is correct.                 |    |                          |
| FRONT MIC IN  |    |                          |
|                      | 1  | GND                      |
|   | 2  | AUDIO IN (H)             |
|   | 3  | AUDIO IN (C)             |
| Panasonic Parts No: K1AY103A0001<br>Manufacturer Parts No: HA16PRM-3SG (72) (Hirose Electric Co.)     |    |                          |
| AUDIO IN  |    |                          |
|                     | 1  | GND                      |
|   | 2  | AUDIO IN (H)             |
|   | 3  | AUDIO IN (C)             |
| Panasonic Parts No: K1AY103A0001<br>Manufacturer Parts No: HA16PRM-3SG (72) (Hirose Electric Co.)     |    |                          |
| REMOTE  |    |                          |
|                    | 1  | CAM DATA (H)             |
|   | 2  | CAM DATA (C)             |
|   | 3  | CAM CONT (H)             |
|   | 4  | CAM CONT (C)             |
|   | 5  | R/C ON                   |
|   | 6  | R/C VIDEO OUT            |
|   | 7  | R/C VIDEO GND            |
|   | 8  | NC                       |
|   | 9  | UNREG+12 V (max. 0.6 A)  |
|   | 10 | GND                      |
| Panasonic Parts No: K1AY110JA001<br>Manufacturer Parts No: HR10A-10R-10SC (71) (Hirose Electric Co.)  |    |                          |
| DC OUT  |    |                          |
|                    | 1  | GND                      |
|   | 2  | R TALLY (open collector) |
|   | 3  | REC SW                   |
|   | 4  | UNREG+12 V (max. 1.5 A)  |
| Panasonic Parts No: K1AY104J0001<br>Manufacturer Parts No: HR10A-7R-4SC (73) (Hirose Electric Co.)    |    |                          |

VF

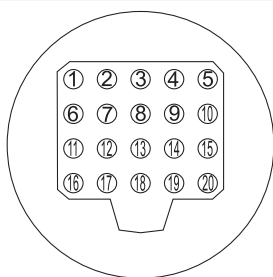

|    |                        |  |
|----|------------------------|--|
| 1  | UNREG-12V              | DC 12 V power (AJ-HVF21KG: approx. 0.35 A)               |
| 2  | UNREG-12V              | DC 12 V power  |
| 3  | A9.0V                  | DC 9 V power (not used)                                  |
| 4  | VF-P <sub>B</sub> -GND | Viewfinder P <sub>B</sub> signal GND                     |
| 5  | VF-P <sub>R</sub> -GND | Viewfinder P <sub>R</sub> signal GND                     |
| 6  | VF-Y                   | Viewfinder Y signal output                               |
| 7  | VF-Y-GND               | Viewfinder Y signal GND                                  |
| 8  | VF-CLK                 | Serial data clock pulse signal                           |
| 9  | VF-WR                  | Pulse signal for serial/parallel conversion data reading |
| 10 | VF-DATA                | Serial data signal for serial/parallel conversion        |
| 11 | UNREG-GND              | GND  |
| 12 | ZEBRA-SW               | Zebra signal ON/OFF                                      |
| 13 | PEAKING                | Peaking control (not used)                               |
| 14 | SPARE                  | Spare (not used)   |
| 15 | VF-P <sub>R</sub>      | Viewfinder P <sub>R</sub> signal output                  |
| 16 | VF-P <sub>B</sub>      | Viewfinder P <sub>B</sub> signal output                  |
| 17 | MARKER-SW              | Marker ON/OFF (not used)                                 |
| 18 | FRONT-VR               | F.AUDIO LEVEL adjustment (not used)                      |
| 19 | VR-GND                 | F.AUDIO LEVEL GND (not used)                             |
| 20 | UNREG-GND              | GND  |

Panasonic Parts No: K1AB120H0001  
 Manufacturer Parts No: HR12-14RA-20SC (Hirose Electric Co.)

**NOTE**

\* Ensure that the total current from the DC OUT, REMOTE, VF, and LENS terminals does not exceed 2.5 A.

LENS

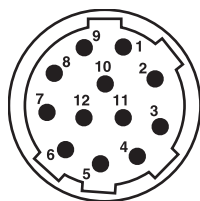

|    |                         |
|----|-------------------------|
| 1  | RET-SW                  |
| 2  | REC                     |
| 3  | GND                     |
| 4  | IRIS-AUTO               |
| 5  | IRIS-CONT               |
| 6  | UNREG+12 V (max. 0.4 A) |
| 7  | IRIS-POSI               |
| 8  | IRIS-G-MAX              |
| 9  | EXT-POSI                |
| 10 | ZOOM-POSI               |
| 11 | FOCUS-POSI              |
| 12 | SPARE                   |

Panasonic Parts No: K1AY112JA001  
 Manufacturer Parts No: HR10A-10R-12SC (71) (Hirose Electric Co.)

## Wireless receiver interface

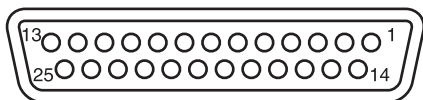

|    |                |   |
|----|----------------|---|
| 1  | CH-1 SHIELD    | GND   |
| 2  | CH-1 HOT       | Audio input from the wireless receiver:<br>CH1 HOT  |
| 3  | CH-1 COLD      | Audio input from the wireless receiver:<br>CH1 COLD |
| 4  | GND            | GND   |
| 5  | UNREG +12 V    | Power supply for the wireless receiver              |
| 6  | RX ON          | Power remote output for the wireless receiver       |
| 7  | RF WARN        | RF warning input from the wireless receiver         |
| 8  | RM5            | Not used  |
| 9  | RM4            | Not used  |
| 10 | SPARE 1        | Not used  |
| 11 | SPARE 2        | Not used  |
| 12 | EXT CLK        | Not used  |
| 13 | CLK SHIELD     | Not used  |
| 14 | CH-2 SHIELD    | GND   |
| 15 | CH-2 HOT       | Audio input from the wireless receiver:<br>CH2 HOT  |
| 16 | CH-2 COLD      | Audio input from the wireless receiver:<br>CH2 COLD |
| 17 | +5.6 V         | Power supply for the wireless receiver              |
| 18 | VIDEO OUT      | Not used  |
| 19 | VIDEO RET      | Not used  |
| 20 | VIDEO EN       | Not used  |
| 21 | RM 1 (RM CLK)  | Not used  |
| 22 | RM 2 (RM DATA) | Not used  |
| 23 | RM 3 (RM WR)   | Not used  |
| 24 | RM+5 V         | Not used  |
| 25 | RM GND         | Not used  |

Panasonic Parts No: K1GB25A00010  
 Manufacturer Parts No: HDBB-25S (05) (Hirose Electric Co.)

## Index

## 0 - 9

25M REC CH SEL ..... 126

## A

ACCESS LED ..... 132  
 A. IRIS LEVEL ..... 121  
 ASPECT CONV ..... 123  
 ATW ..... 54, 123  
 AUD01:LEVEL ..... 140  
 AUD02:INPUT ..... 141  
 AUD03:MONI ..... 141  
 Audio input ..... 60  
 AUDIO SETUP screen ..... 125  
 AUTO KNEE SW ..... 124  
 Automatic black balance ..... 55  
 AUTO REC ..... 127, 167  
 Auto tracking white balance ..... 54

## B

Battery ..... 88  
   Mounting ..... 88  
   Setting ..... 88  
 BATTERY MODE ..... 129  
 BATTERY SELECT ..... 129  
 BATTERY SETUP screen ..... 128  
 Black balance ..... 55  
 Built-in battery ..... 156

## C

CAC ..... 93, 130  
 CAC CARD READ ..... 130  
 CAC FILE DELETE ..... 130  
 CAC FILE INIT ..... 130  
 CAC PROPERTY ..... 130  
 CAM01:STATUS ..... 138  
 CAM02:SCENE FILE ..... 138  
 CAM03:SETUP ..... 139  
 CAMERA MODE ..... 123  
 CARD/BATT ..... 128  
 CARD FUNCTIONS screen ..... 130  
 Center marker ..... 79  
 CHROMA LEVEL ..... 120  
 CHROMA PHASE ..... 120  
 Chromatic aberration compensation function ..... 93  
 Cine-like gamma ..... 38  
 Clip ..... 100  
   Copying ..... 108  
   Deleting ..... 107  
   Metadata ..... 108  
   Playback ..... 104  
   Properties ..... 112  
   Reconnecting ..... 107  
   Restoring ..... 107  
 Clock ..... 31  
 CLOCK SETTING ..... 132  
 COLOR TEMP Ach ..... 120  
 COLOR TEMP Bch ..... 120  
 Connector signal ..... 173  
 Counter ..... 69  
 Cue up ..... 46

## D

Date and time ..... 31  
 DATE/TIME ..... 128  
 DC power supply ..... 89  
 DETAIL CORING ..... 120  
 DETAIL LEVEL ..... 120  
 DIAGNOSTIC screen ..... 133  
 Dimensions ..... 169  
 DIONIC90 NEAR ..... 129  
 DIONIC160 NEAR ..... 129  
 DIONIC HC NEAR ..... 129  
 DISPLAY SETUP screen ..... 127

DRS ..... 12  
 DRS EFFECT ..... 121  
 Dynamic range stretcher function ..... 12

## E

Electronic shutter ..... 56  
 ENDURA7 NEAR ..... 129  
 ENDURA10 NEAR ..... 129  
 Error displays ..... 75, 158  
 EVF COLOR ..... 128  
 EVF PEAK FREQ ..... 127  
 EVF PEAK LEVEL ..... 127  
 EVF TYPE ..... 127  
 EXT DC IN SEL ..... 128  
 External DC power supply ..... 89  
 External power supply ..... 89

## F

Fast-forward playback ..... 46  
 Fast-reverse playback ..... 46  
 F.AUDIO LEVEL dial ..... 60  
 FB ADJUST ..... 130  
 FBC ..... 58  
 Flange back adjustment ..... 91  
 Flash band compensation ..... 58  
 F.MIC LEVEL ..... 126  
 F.MIC POWER ..... 126  
 Focus assist ..... 80  
 FOCUS BAR ..... 128  
 Formatting  
   Hard disk drive ..... 149  
   P2 card ..... 111  
   SD memory card ..... 83, 111

FRAME RATE ..... 120  
 Front microphone ..... 96  
 FRONT VR CH1 ..... 125  
 FRONT VR CH2 ..... 125  
 FRONT VR CH3 ..... 125  
 FRONT VR CH4 ..... 125

## G

GAMMA ..... 121  
 Generator lock ..... 69  
 GL PHASE ..... 132

## H

HD SDI REMOTE ..... 127  
 HEADROOM ..... 126  
 HIGH GAIN ..... 123  
 Hot swap recording ..... 44  
 H PHASE ..... 132  
 HYTRON50 NEAR ..... 129  
 HYTRON140 NEAR ..... 129

## I

IN/OUT SEL screen ..... 127  
 Interval recording ..... 41  
 INTERVAL TIME ..... 124  
 IRIS ADJUST ..... 130  
 IRIS GAIN ..... 130  
 IRIS GAIN VALUE ..... 130

## K

KNEE ..... 121

## L

Lens ..... 91  
   Adjusting ..... 91  
   Mounting ..... 91  
 LENS SETUP screen ..... 130  
 LEVEL METER ..... 128  
 LIMITER CH1 ..... 126  
 LIMITER CH2 ..... 126  
 LIMITER CH3 ..... 126



**Index**

|  |     |  |          |
|--|-----|--|----------|
| LIMITER CH4 .....                          | 126 | REC MEDIA .....                              | 131, 162 |
| LOAD/SAVE/INIT .....                       | 120 | REC MODE (720) .....                         | 131, 162 |
| Loop recording .....                       | 42  | REC MODE (1080) .....                        | 131, 162 |
| LOW GAIN .....                             | 123 | REC MODE (SD) .....                          | 131, 162 |
| <b>M</b>                                   |     | Recording format .....                       | 48       |
| MARKER .....                               | 128 | Recording functions .....                    | 41       |
| MASTER PED .....                           | 121 | Recording levels .....                       | 60       |
| MATRIX .....                               | 121 | RECORDING SETUP screen .....                 | 124      |
| Menu                                       |     | Rec review function .....                    | 44       |
| Setting menu .....                         | 116 | REC SIGNAL .....                             | 122, 167 |
| Thumbnail menu .....                       | 101 | REC TALLY .....                              | 132      |
| MENU BACK .....                            | 128 | Remote control .....                         | 151      |
| MENU INIT .....                            | 132 | RET SW .....                                 | 124      |
| Metadata .....                             | 108 | R.MIC CH1 LEVEL .....                        | 126      |
| MIC LOWCUT CH1 .....                       | 125 | R.MIC CH2 LEVEL .....                        | 126      |
| MIC LOWCUT CH2 .....                       | 125 | <b>S</b>                                     |          |
| MIC LOWCUT CH3 .....                       | 125 | Safety zone .....                            | 79       |
| MIC LOWCUT CH4 .....                       | 126 | SAFETY ZONE .....                            | 128      |
| Microphone .....                           | 96  | SCAN REVERSE .....                           | 123      |
| MID GAIN .....                             | 123 | Scene file .....                             | 84       |
| Mode check .....                           | 78  | SCENE FILE .....                             | 130      |
| MODEL NAME .....                           | 133 | Scene file data .....                        | 84       |
| MON/HDMI ZEBRA .....                       | 127 | SCENE FILE screen .....                      | 120      |
| <b>N</b>                                   |     | SD CARD FORMAT .....                         | 130      |
| NAME EDIT .....                            | 121 | SDI EDH .....                                | 127      |
| Native recording .....                     | 37  | SDI METADATA .....                           | 127      |
| Native variable frame rate recording ..... | 38  | SDI OUT .....                                | 127      |
| NEAR END CANCEL .....                      | 129 | SDI OUT CHAR .....                           | 127      |
| NETWORK SEL .....                          | 132 | SD memory card .....                         | 25       |
| Normal speed playback .....                | 46  | Formatting .....                             | 83, 111  |
| <b>O</b>                                   |     | Handling .....                               | 82       |
| ONE CLIP REC .....                         | 125 | Inserting .....                              | 82       |
| One-clip recording .....                   | 43  | Operation .....                              | 83       |
| One-shot recording .....                   | 42  | Removing .....                               | 83       |
| ONE SHOT TIME .....                        | 124 | Status display .....                         | 114      |
| OPERATION .....                            | 133 | SEEK SELECT .....                            | 132      |
| OPTION STATUS .....                        | 133 | SERIAL NO. .....                             | 133      |
| OTHER DISPLAY .....                        | 128 | SET01:TC/UB .....                            | 142      |
| OTHER FUNCTIONS screen .....               | 132 | SET02:MON/HDMI FORMAT .....                  | 143      |
| Overcrank shooting .....                   | 40  | SET03:MON/HDMI SETUP .....                   | 143      |
| <b>P</b>                                   |     | SET04:LCD .....                              | 143      |
| P2 BROWSE .....                            | 132 | Setting menu .....                           | 116      |
| P2 card .....                              | 32  | Basic operations .....                       | 116      |
| Formatting .....                           | 111 | Initialization .....                         | 117      |
| Inserting .....                            | 32  | SETUP .....                                  | 123      |
| Recording time .....                       | 33  | SHADING SELECT .....                         | 130      |
| Removing .....                             | 32  | SHADING (USER) .....                         | 130      |
| Status .....                               | 33  | Shooting .....                               | 35       |
| Status display .....                       | 113 | Shot mark .....                              | 44       |
| Write protect .....                        | 33  | Shot mark recording .....                    | 44       |
| Writing back .....                         | 149 | Shoulder strap .....                         | 97       |
| P2CARD REMAIN .....                        | 128 | Shutter mode .....                           | 56       |
| PAG L96e NEAR .....                        | 129 | Shutter speed .....                          | 56       |
| PC MODE .....                              | 131 | SKIN TONE DTL .....                          | 121      |
| PC MODE SEL .....                          | 131 | SmartUI                                      |          |
| PC/USB/LAN screen .....                    | 131 | AUDIO screen .....                           | 140      |
| Playback .....                             | 46  | CAMERA screen .....                          | 138      |
| PLAYLIST .....                             | 132 | SETUP screen .....                           | 142      |
| PREREC MODE .....                          | 125 | TEXT MEMO screen .....                       | 144      |
| Pre-recording .....                        | 41  | Specifications .....                         | 169      |
| Properties .....                           | 112 | Standard recording .....                     | 36       |
| PROXY FPGA .....                           | 162 | Standard variable frame rate recording ..... | 38       |
| Proxy recording .....                      | 44  | START DELAY .....                            | 124      |
| PROXY SETTING screen .....                 | 131 | START TEXT MEMO .....                        | 125      |
| PROXY SOFT .....                           | 162 | STREAMING MODE .....                         | 131      |
| Pull-down recording .....                  | 37  | SW MODE screen .....                         | 123      |
| <b>R</b>                                   |     | SYNCHRO SCAN .....                           | 120      |
| Rain cover .....                           | 98  | Synchro scan mode .....                      | 56       |
| REC COUNTER .....                          | 128 | SYNC SCAN TYPE .....                         | 120      |
| REC FORMAT .....                           | 122 | SYSTEM MODE .....                            | 122      |
| REC FUNCTION .....                         | 124 | <b>T</b>                                     |          |
|  |     | TC IN/OUT SEL .....                          | 127      |
|  |     | TC MODE .....                                | 125      |

|                                     |          |
|-------------------------------------|----------|
| TC OUT .....                        | 127      |
| TC SUPER .....                      | 131, 162 |
| TC VIDEO SYNC .....                 | 127      |
| TEST TONE .....                     | 126      |
| TEX01:CLIP INFO .....               | 144      |
| TEX02:MEMO1 .....                   | 144      |
| TEX03:MEMO2 .....                   | 144      |
| Text memo recording .....           | 45       |
| Thumbnail .....                     | 101      |
| Changing .....                      | 104      |
| Menu .....                          | 101      |
| Selecting .....                     | 103      |
| Switching .....                     | 104      |
| Time code .....                     | 66       |
| Time data .....                     | 61       |
| Time zone .....                     | 31       |
| TIME ZONE .....                     | 132      |
| Tripod .....                        | 97       |
| TYPE A END .....                    | 129      |
| TYPE A FULL .....                   | 129      |
| TYPE A NEAR .....                   | 129      |
| TYPE B END .....                    | 129      |
| TYPE B FULL .....                   | 129      |
| TYPE B NEAR .....                   | 129      |
| <b>U</b>                            |          |
| UB MODE .....                       | 125      |
| Undercrank shooting .....           | 39       |
| USB .....                           | 146      |
| Device mode .....                   | 146      |
| Host mode .....                     | 146      |
| USER1 .....                         | 124      |
| USER2 .....                         | 124      |
| User bits .....                     | 64       |
| USER buttons .....                  | 59       |
| USER FILE .....                     | 130      |
| USER MAIN .....                     | 124      |
| Using SmartUI .....                 | 134      |
| <b>V</b>                            |          |
| Variable frame rate recording ..... | 38       |
| Variable speed playback .....       | 46       |
| V DETAIL FREQ .....                 | 121      |
| V DETAIL LEVEL .....                | 120      |
| VERSION .....                       | 133      |
| VFR .....                           | 38, 120  |
| Viewfinder .....                    |          |
| Screen display .....                | 71       |
| Status display .....                | 70       |
| <b>W</b>                            |          |
| Warning displays .....              | 75       |
| Warning system .....                | 157      |
| Waveform monitor function .....     | 81       |
| W.BAL.PRESET .....                  | 123      |
| WFM .....                           | 124      |
| White balance .....                 | 53       |
| White shading compensation .....    | 92       |
| Wireless receiver .....             | 96       |
| WIRELESS TYPE .....                 | 126      |
| WIRELESS WARN .....                 | 126      |
| <b>Z</b>                            |          |
| ZEBRA1 DETECT .....                 | 128      |
| ZEBRA2 .....                        | 128      |
| ZEBRA2 DETECT .....                 | 128      |
| Zebra patterns .....                | 80       |
| ZOOM/FOCUS .....                    | 128      |

## Information for Users on Collection and Disposal of Old Equipment and used Batteries



These symbols on the products, packaging, and/or accompanying documents mean that used electrical and electronic products and batteries should not be mixed with general household waste. For proper treatment, recovery and recycling of old products and used batteries, please take them to applicable collection points, in accordance with your national legislation and the Directives 2002/96/EC and 2006/66/EC.



EU

By disposing of these products and batteries correctly, you will help to save valuable resources and prevent any potential negative effects on human health and the environment which could otherwise arise from inappropriate waste handling.



For more information about collection and recycling of old products and batteries, please contact your local municipality, your waste disposal service or the point of sale where you purchased the items.

Penalties may be applicable for incorrect disposal of this waste, in accordance with national legislation.

EU

### **For business users in the European Union**

If you wish to discard electrical and electronic equipment, please contact your dealer or supplier for further information.



Cd

### **Information on Disposal in other Countries outside the European Union**

These symbols are only valid in the European Union. If you wish to discard these items, please contact your local authorities or dealer and ask for the correct method of disposal.

### **Note for the battery symbol (bottom two symbol examples):**

This symbol might be used in combination with a chemical symbol. In this case it complies with the requirement set by the Directive for the chemical involved.