

# RACK MOUNT KIT

## RMK-2



## Quick Start Guide

[www.datavideo-tek.com](http://www.datavideo-tek.com)

## Warnings and Precautions

1. Read all of these warnings and save them for later reference.
2. Follow all warnings and instructions marked on this unit.
3. Unplug this unit from the wall outlet before cleaning. Do not use liquid or aerosol cleaners. Use a damp cloth for cleaning.
4. Do not use this unit in or near water.
5. Do not place this unit on an unstable cart, stand, or table. The unit may fall, causing serious damage.
6. Slots and openings on the cabinet top, back, and bottom are provided for ventilation. To ensure safe and reliable operation of this unit, and to protect it from overheating, do not block or cover these openings. Do not place this unit on a bed, sofa, rug, or similar surface, as the ventilation openings on the bottom of the cabinet will be blocked. This unit should never be placed near or over a heat register or radiator. This unit should not be placed in a built-in installation unless proper ventilation is provided.
7. This product should only be operated from the type of power source indicated on the marking label of the AC adapter. If you are not sure of the type of power available, consult your Datavideo dealer or your local power company.
8. Do not allow anything to rest on the power cord. Do not locate this unit where the power cord will be walked on, rolled over, or otherwise stressed.
9. If an extension cord must be used with this unit, make sure that the total of the ampere ratings on the products plugged into the extension cord do not exceed the extension cord's rating.
10. Make sure that the total amperes of all the units that are plugged into a single wall outlet do not exceed 15 amperes.
11. Never push objects of any kind into this unit through the cabinet ventilation slots, as they may touch dangerous voltage points or short out parts that could result in risk of fire or electric shock. Never spill liquid of any kind onto or into this unit.
12. Except as specifically explained elsewhere in this manual, do not attempt to service this product yourself. Opening or removing covers that are marked "Do Not Remove" may expose you to dangerous voltage points or other risks, and will void your warranty. Refer all service issues to qualified service personnel.
13. Unplug this product from the wall outlet and refer to qualified service personnel under the following conditions:
  - a. When the power cord is damaged or frayed;
  - b. When liquid has spilled into the unit;
  - c. When the product has been exposed to rain or water;
  - d. When the product does not operate normally under normal operating conditions. Adjust only those controls that are covered by the operating instructions in this manual; improper adjustment of other controls may result in damage to the unit and may often require extensive work by a qualified technician to restore the unit to normal operation;
  - e. When the product has been dropped or the cabinet has been damaged;
  - f. When the product exhibits a distinct change in performance, indicating a need for service.

## Warranty

### Standard Warranty

- Datavideo equipment is guaranteed against any manufacturing defects for one year from the date of purchase.
- The original purchase invoice or other documentary evidence should be supplied at the time of any request for repair under warranty.
- Damage caused by accident, misuse, unauthorized repairs, sand, grit or water is not covered by this warranty.
- All mail or transportation costs including insurance are at the expense of the owner.
- All other claims of any nature are not covered.
- Cables & batteries are not covered under warranty.
- Warranty only valid within the country or region of purchase.
- Your statutory rights are not affected.

### Two Year Warranty

- All Datavideo products purchased after 01-Oct.-2008 qualify for a free one year extension to the standard Warranty, providing the product is registered with Datavideo within 30 days of purchase. For information on how to register please visit [www.datavideo-tek.com](http://www.datavideo-tek.com) or contact your local Datavideo office or authorized Distributors
- Certain parts with limited lifetime expectancy such as LCD Panels, DVD Drives, Hard Drives are only covered for the first 10,000 hours, or 1 year (whichever comes first).

Any second year warranty claims must be made to your local Datavideo office or one of its authorized Distributors before the extended warranty expires.

## Disposal

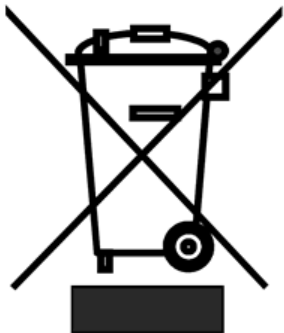

### For EU Customers only - WEEE Marking

This symbol on the product indicates that it will not be treated as household waste. It must be handed over to the applicable take back scheme for the recycling of electrical and electronic equipment. For more detailed information about the recycling of this product, please contact your local Datavideo office.

## Product Overview

The Datavideo RMK-2 is a tool to stack Datavideo DAC-8P/9P. The product makes customers to install several DAC devices easy and neat. With 16 DC output, customer can install DAC device at any direction they want. Adjusted ear rack helps customer to install RMK-2 deeper. It will reduce the risk of kicking of cables by accident.

## Features

- Supports Maximum up to 8 DAC-8P/9P
- Easy install with no limitation
- 1 DC in 16 DC out to support different installation of DAC
- Flexible install way with adjusted ear rack

# Internal / External Out-Looking with I/O

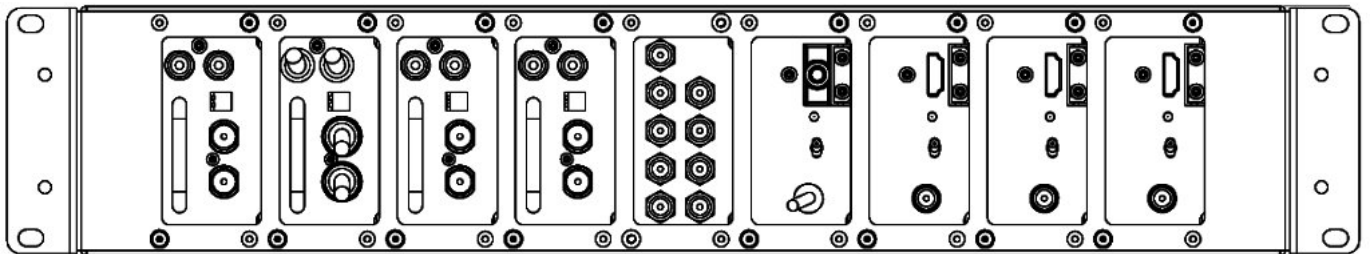
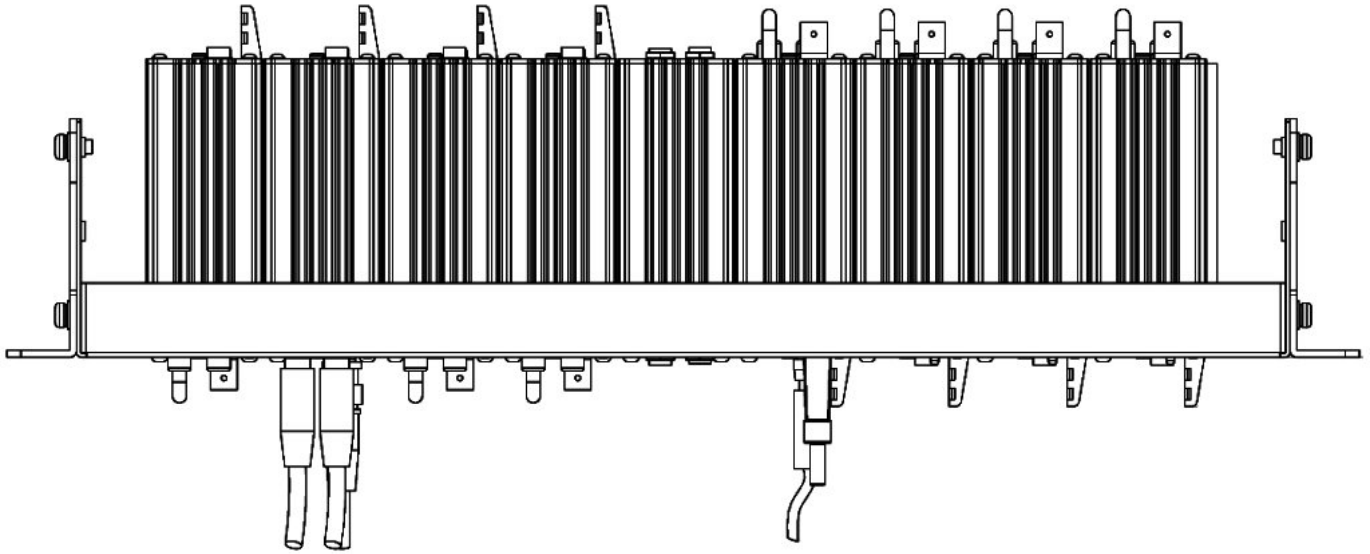
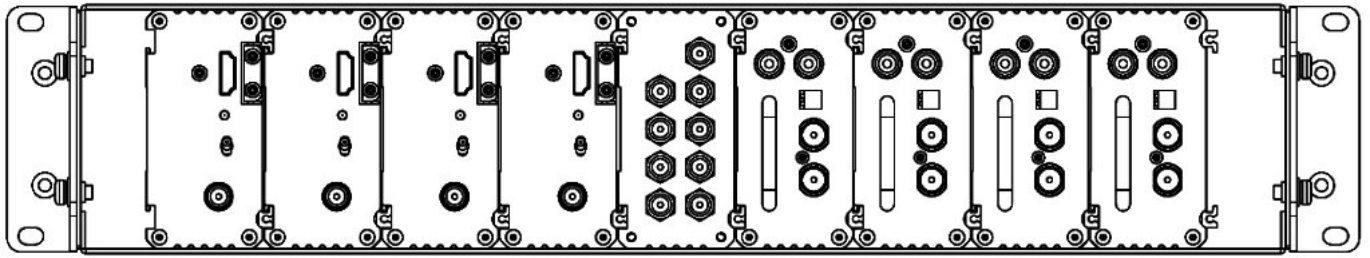

## Service & Support

It is our goal to make your products ownership a satisfying experience. Our supporting staff is available to assist you in setting up and operating your system. Please refer to our web site [www.datavideo-tek.com](http://www.datavideo-tek.com) for answers to common questions, support requests or contact your local office below.

Datavideo Global Website: [www.datavideo-tek.com](http://www.datavideo-tek.com)

### Datavideo Corporation

Tel: +1 562 696 2324	Fax: +1 562-698-6930	E-Mail: <a href="mailto:contactus@datavideo.us">contactus@datavideo.us</a>
----------------------	----------------------	--

### Datavideo Technologies Europe BV

Tel: +31-30-261-96-56	Fax: +31-30 261-96-57	E-Mail: <a href="mailto:service@datavideo.nl">service@datavideo.nl</a>
-----------------------	-----------------------	--

### Datavideo UK Limited

Tel: +44 1457 851 000	Fax: +44 1457 850 964	E-Mail: <a href="mailto:sales@datavideo.co.uk">sales@datavideo.co.uk</a>
-----------------------	-----------------------	--

### Datavideo Technologies Co., Ltd

Tel: +886 2 8227 2888	Fax: +886-2-8227-2777	E-mail: <a href="mailto:service@datavideo.com.tw">service@datavideo.com.tw</a>
-----------------------	-----------------------	--

### Datavideo Technologies China Co., Ltd

Tel: +86 21-5603 6599	Fax: +86 21-5603 6770	E-mail: <a href="mailto:service@datavideo.cn">service@datavideo.cn</a>
-----------------------	-----------------------	--

### Datavideo Technologies (S) PTE LTD

Tel: +65-6749 6866	Fax: +65-6749 3266	E-mail: <a href="mailto:service@datavideo.sg">service@datavideo.sg</a>
--------------------	--------------------	--

### Datavideo HK Limited.

Tel: +852 2833 1981	Fax: +852-2833-9916	E-mail: <a href="mailto:info@datavideo.com.hk">info@datavideo.com.hk</a>
---------------------	---------------------	--

### Datavideo France

Tel: +33 1 60 37 02 46	Fax: +33 1 60 37 67 32	E-Mail: <a href="mailto:info@datavideo.fr">info@datavideo.fr</a>
------------------------	------------------------	--

### Datavideo India

Tel: +91-0120-2427337	Fax: +91-0120-2427338	E-Mail: <a href="mailto:sales@datavideo.in">sales@datavideo.in</a>
-----------------------	-----------------------	--

All the trademarks are the properties of their respective owners.  
Datavideo Technologies Co., Ltd. All rights reserved 2018